



US00D573102S

(12) **United States Design Patent**
Sheehan

(10) **Patent No.:** **US D573,102 S**
(45) **Date of Patent:** **** Jul. 15, 2008**

(54) **ELECTRICAL CONDUIT TO JUNCTION BOX CONNECTION SYSTEM**

(76) Inventor: **Robert K. Sheehan**, 1520 Cohasset Ct., Cincinnati, OH (US) 45455

(**) Term: **14 Years**

(21) Appl. No.: **29/253,297**

(22) Filed: **Feb. 2, 2006**

(51) **LOC (8) Cl.** **13-03**

(52) **U.S. Cl.** **D13/153**

(58) **Field of Classification Search** D13/153, D13/154, 156; 285/195, 154.3; 174/64, 174/65 R, 350, 655, 657; 429/142, 552

See application file for complete search history.

(56) **References Cited**

U.S. PATENT DOCUMENTS

377,506 A	2/1888	Whiter
1,049,283 A	12/1912	Westphal
1,131,399 A	3/1915	McGinley
1,355,450 A	10/1920	Carlson
2,241,293 A	5/1941	Campbell
2,457,235 A	12/1948	Hoehn
2,466,504 A	4/1949	Stoyer
2,973,212 A	2/1961	Rose
3,788,582 A	1/1974	Swanquist
3,981,061 A	9/1976	Jackson et al.
4,151,363 A	4/1979	Nichols
4,641,863 A	2/1987	Shemtov
4,699,217 A	10/1987	McLennan et al.
4,711,974 A	12/1987	Borsh

5,200,575 A	4/1993	Sheehan	
5,647,613 A *	7/1997	Marik et al.	285/195
6,140,582 A	10/2000	Sheehan	
6,231,088 B1	5/2001	Balthazard et al.	
6,232,553 B1 *	5/2001	Regen	174/350
6,511,099 B2	1/2003	Bartholoma et al.	
D473,783 S *	4/2003	Kiely	D8/396
D479,984 S *	9/2003	Kiely	D8/396
D518,791 S *	4/2006	Kiely	D13/153

* cited by examiner

Primary Examiner—Brian N Vinson

(74) *Attorney, Agent, or Firm*—Gallagher & Dawsey Co. LPA; Michael J. Gallagher; David J. Dawsey

(57) **CLAIM**

The ornamental design for an electrical conduit to junction box connection system, as shown and described.

DESCRIPTION

FIG. 1 is a perspective view of an electrical conduit to junction box connection system showing my new design;

FIG. 2 is a left elevation view thereof;

FIG. 3 is a rear elevation view thereof;

FIG. 4. is a right elevation view thereof;

FIG. 5 is a top plan view thereof;

FIG. 6 is a front elevation view thereof; and,

FIG. 7 is a bottom plan view thereof.

The broken lines are for illustrative purposes only and form no part of the claimed design.

1 Claim, 3 Drawing Sheets

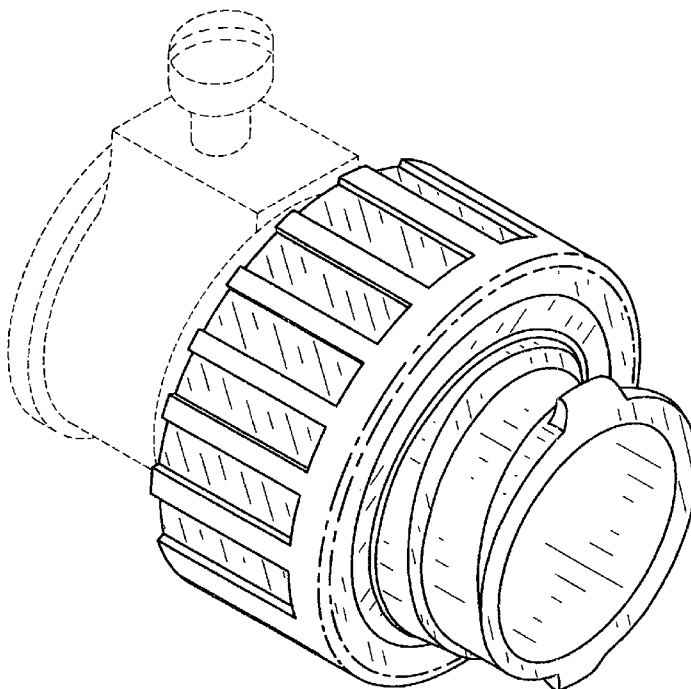

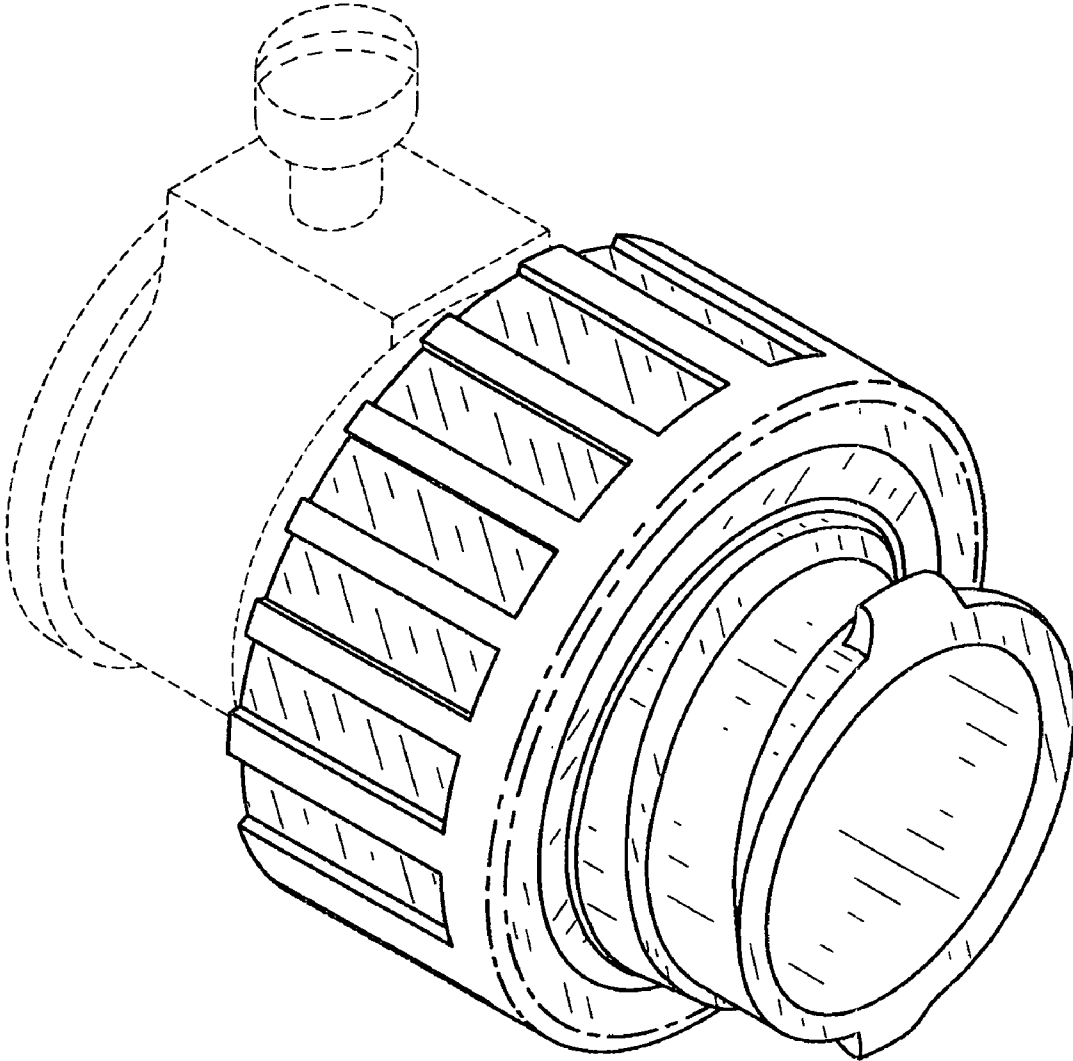

FIG. 1

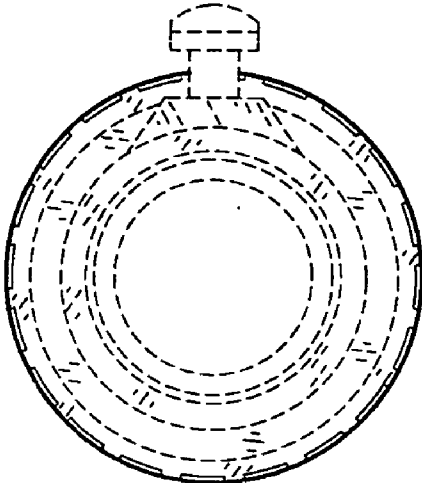

FIG. 2

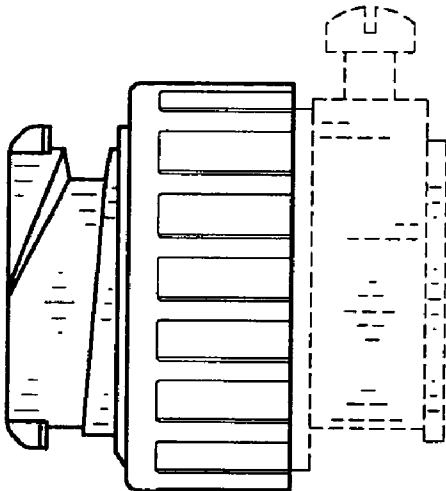

FIG. 3

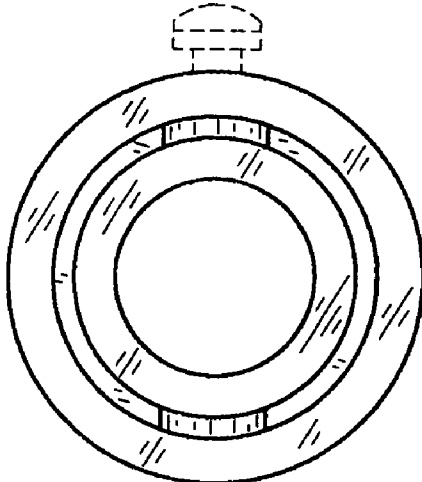

FIG. 4

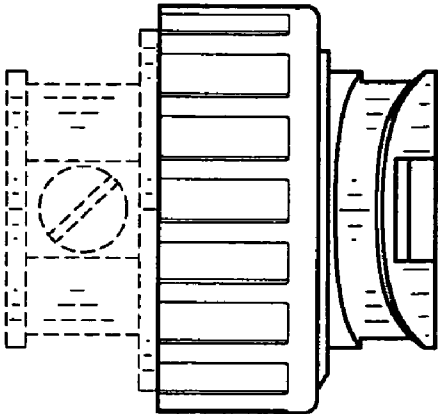

FIG. 5

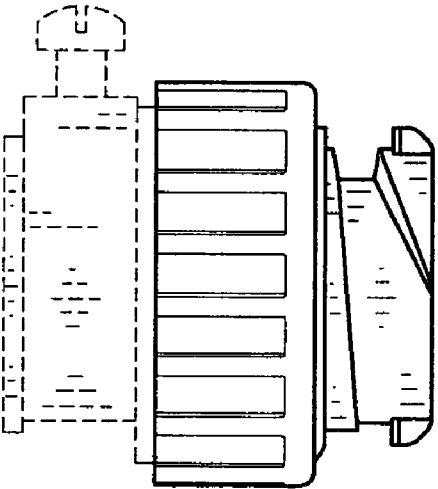

FIG. 6

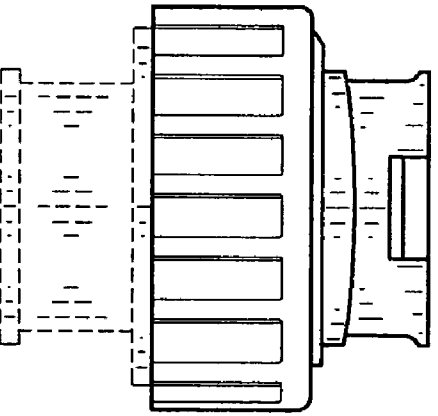

FIG. 7