



US006866120B1

(12) **United States Patent**
Butterworth

(10) **Patent No.:** **US 6,866,120 B1**
(45) **Date of Patent:** **Mar. 15, 2005**

(54) **PORTABLE TREE STAND HAVING SEATING AND STANDING PLATFORMS ADJUSTABLE TO TREE ANGLE**

(76) **Inventor:** **Charles Butterworth**, 38055 Mt. Union Rd., Pomeroy, OH (US) 45769

(*) **Notice:** Subject to any disclaimer, the term of this patent is extended or adjusted under 35 U.S.C. 154(b) by 0 days.

(21) **Appl. No.:** **10/644,457**

(22) **Filed:** **Aug. 20, 2003**

(51) **Int. Cl.⁷** **E04G 3/00; A63B 27/00; A47B 5/00**

(52) **U.S. Cl.** **182/187; 182/135; 108/152**

(58) **Field of Search** 182/135, 136, 182/187, 188, 116, 20; 297/217.1; 108/152

(56) **References Cited**

U.S. PATENT DOCUMENTS

4,549,635 A	*	10/1985	Early	182/187
4,819,763 A		4/1989	Grote	
4,936,416 A		6/1990	Garon	
5,199,527 A		4/1993	Jennings	
5,868,221 A		2/1999	Brack, Jr.	
RE36,276 E	*	8/1999	Smith	182/187
5,954,158 A		9/1999	Concepcion	
6,085,868 A	*	7/2000	Anthony et al.	182/187
6,196,354 B1		3/2001	Anthony et al.	

6,367,585 B1	*	4/2002	Fast	182/187
6,386,321 B1		5/2002	Muhich	
6,568,505 B1		5/2003	D'Acquisto	
6,571,916 B1		6/2003	Swanson	
6,578,913 B2	*	6/2003	Wilhelm	297/217.7
6,722,472 B2	*	4/2004	Berkbuegler	182/187

* cited by examiner

Primary Examiner—Hugh B. Thompson, II
(74) *Attorney, Agent, or Firm*—David J. Dawsey; Michael J. Gallagher; Gallagher and Dawsey Co., LPA

(57) **ABSTRACT**

A portable tree stand for use with non-vertical trees provides standing and seating platforms that may remain parallel and may be adjustable. Adjustments include a slidable seat platform and a slidable standing platform that may be extended to allow adequate seating and standing space to compensate for tree trunks that diverge from the vertical. Additionally, the distance, or height, between the standing platform and the seating platform maybe varied. A threaded chain tensioner tightens a chain around the tree helping hold the stand to the tree, and optionally a tree screw secures attachment to the tree trunk. An adjustable seat support post establishes a parallelogram relationship between the seat platform and the standing platform such that an angular relationship, which may be parallel or non-parallel, may be maintained between the seat platform and the standing platform.

20 Claims, 9 Drawing Sheets

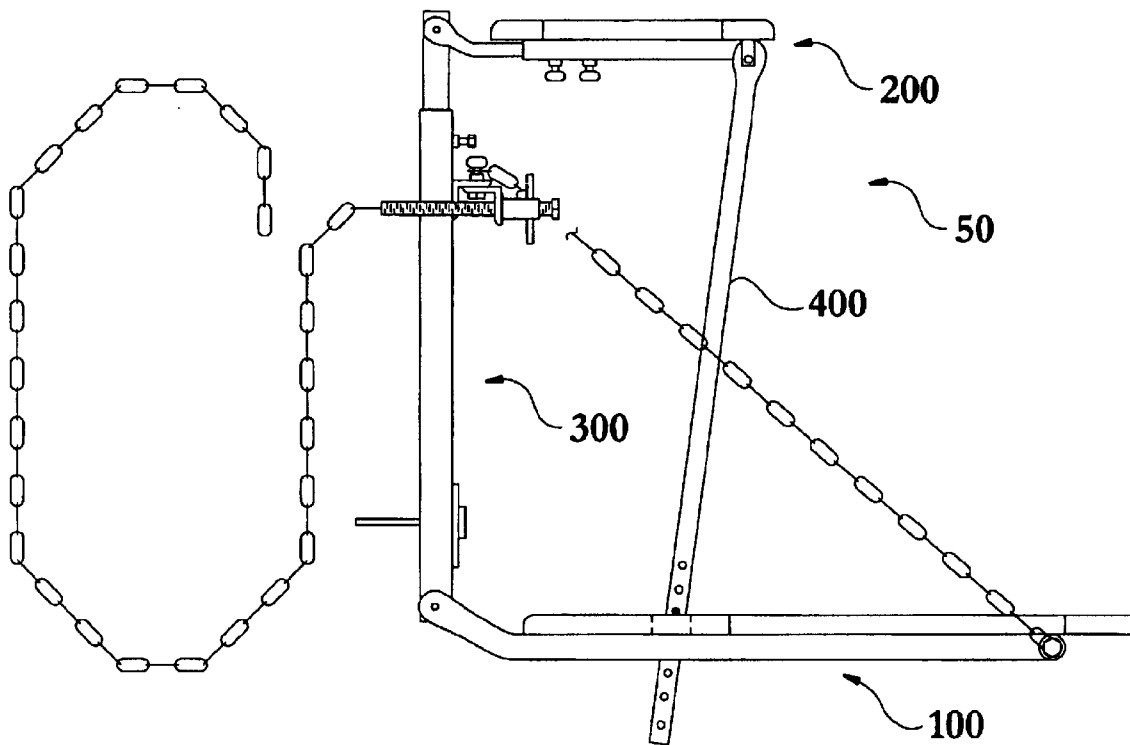

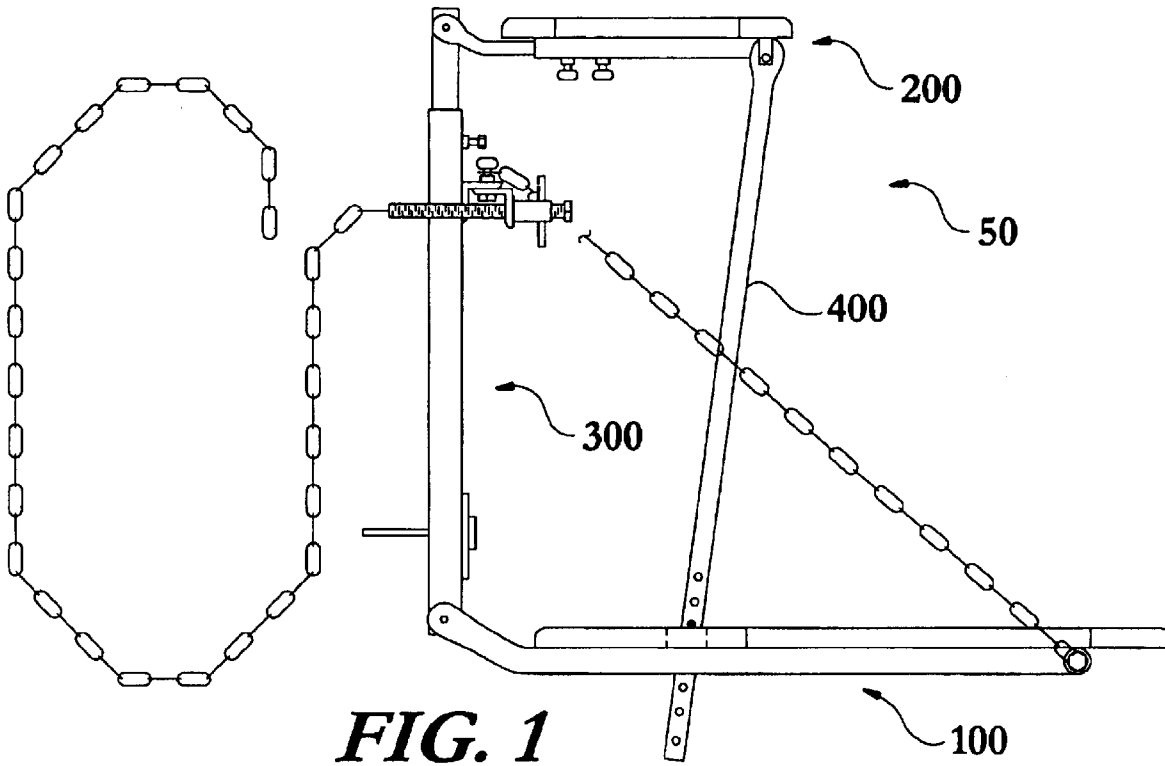

FIG. 1

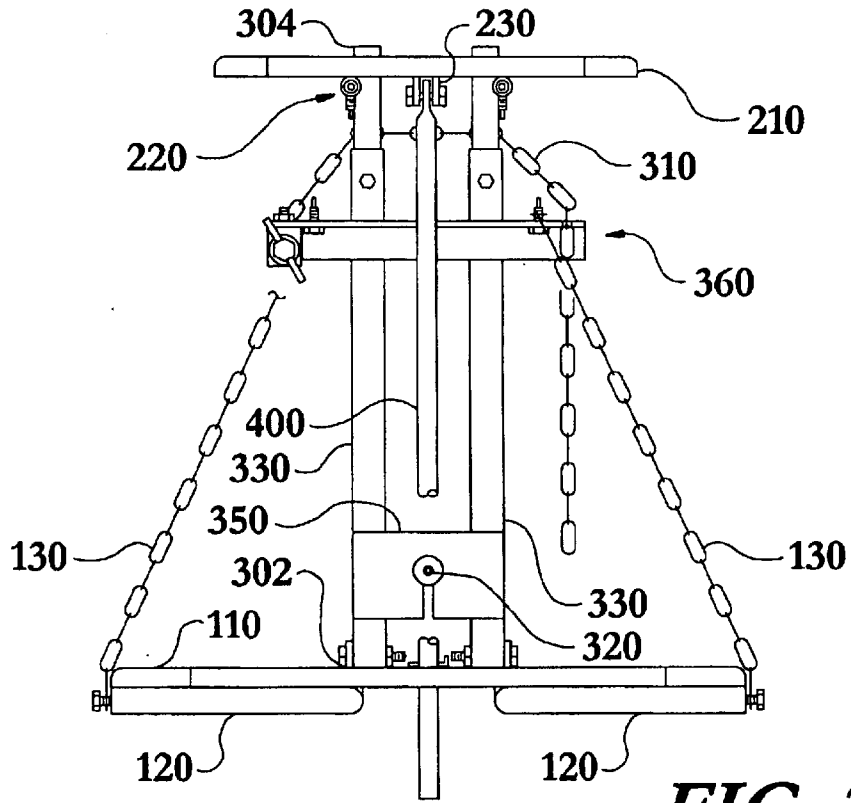

FIG. 2

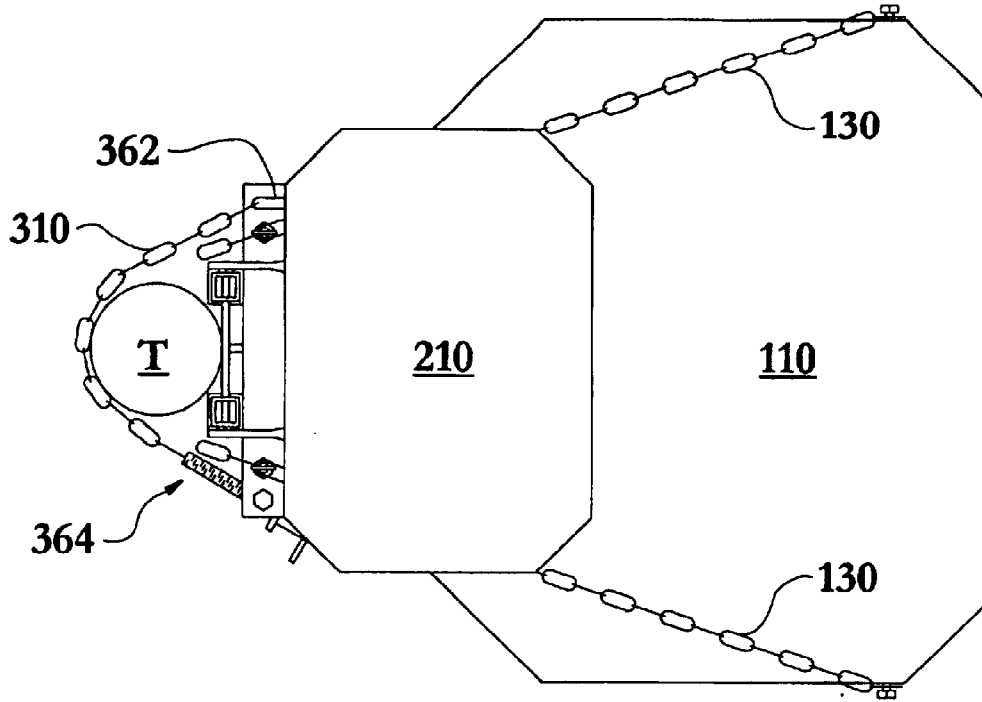

FIG. 3

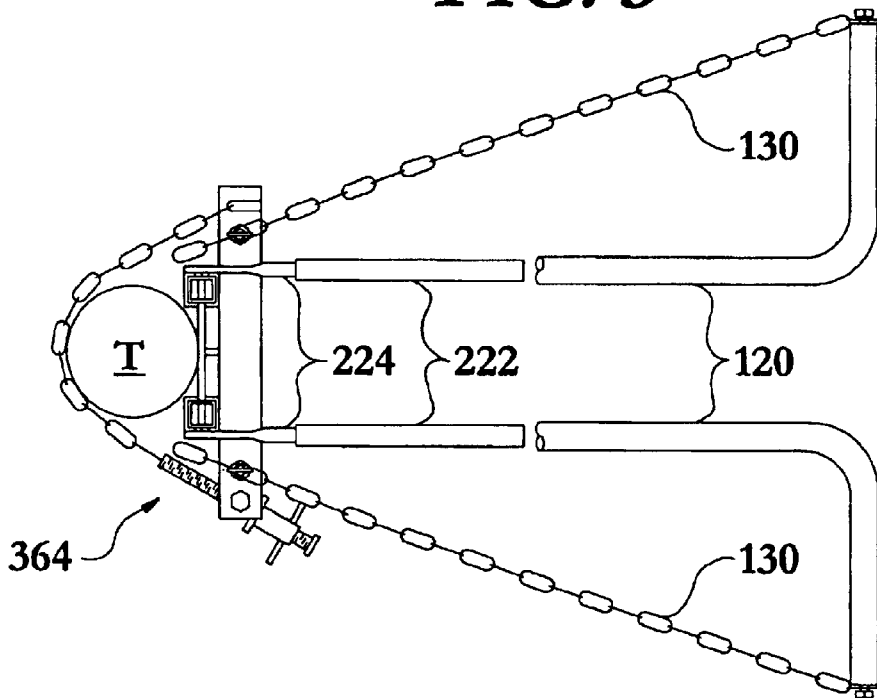

FIG. 4

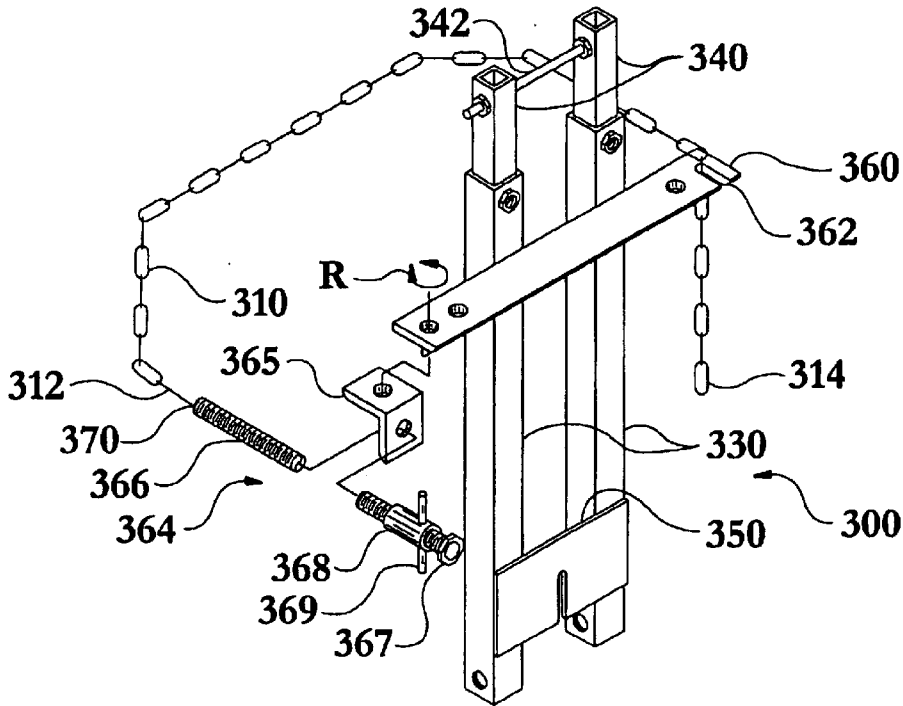

FIG. 5

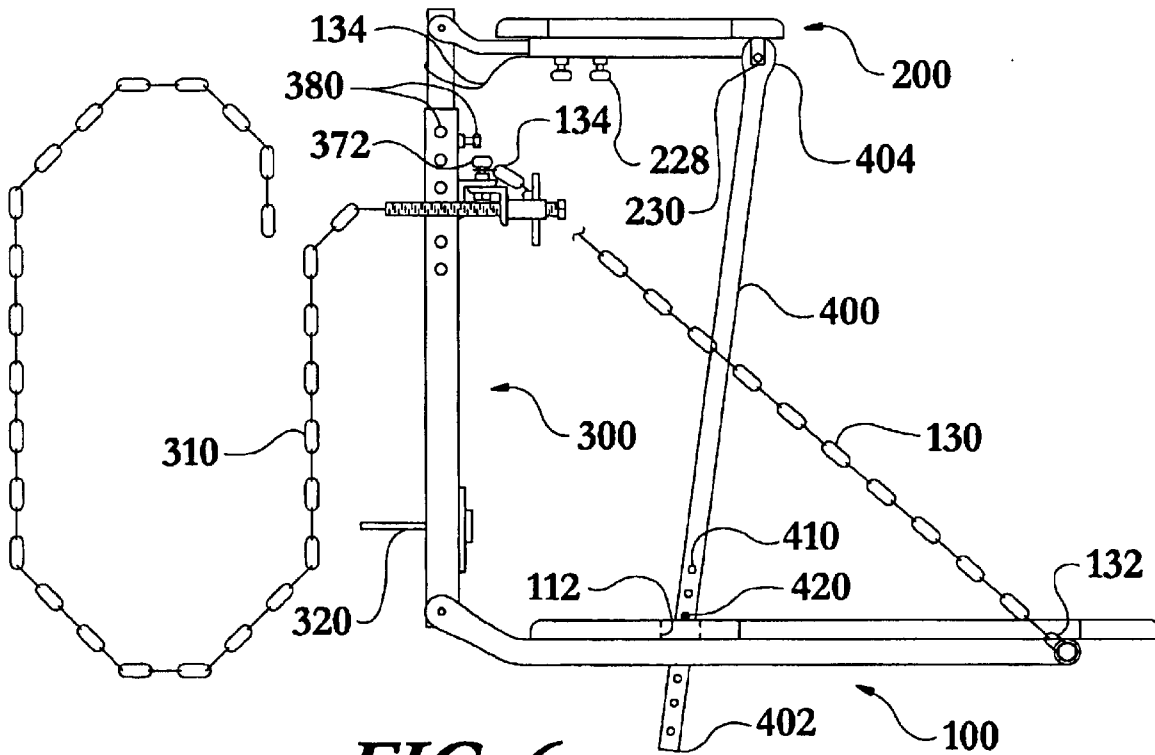

FIG. 6

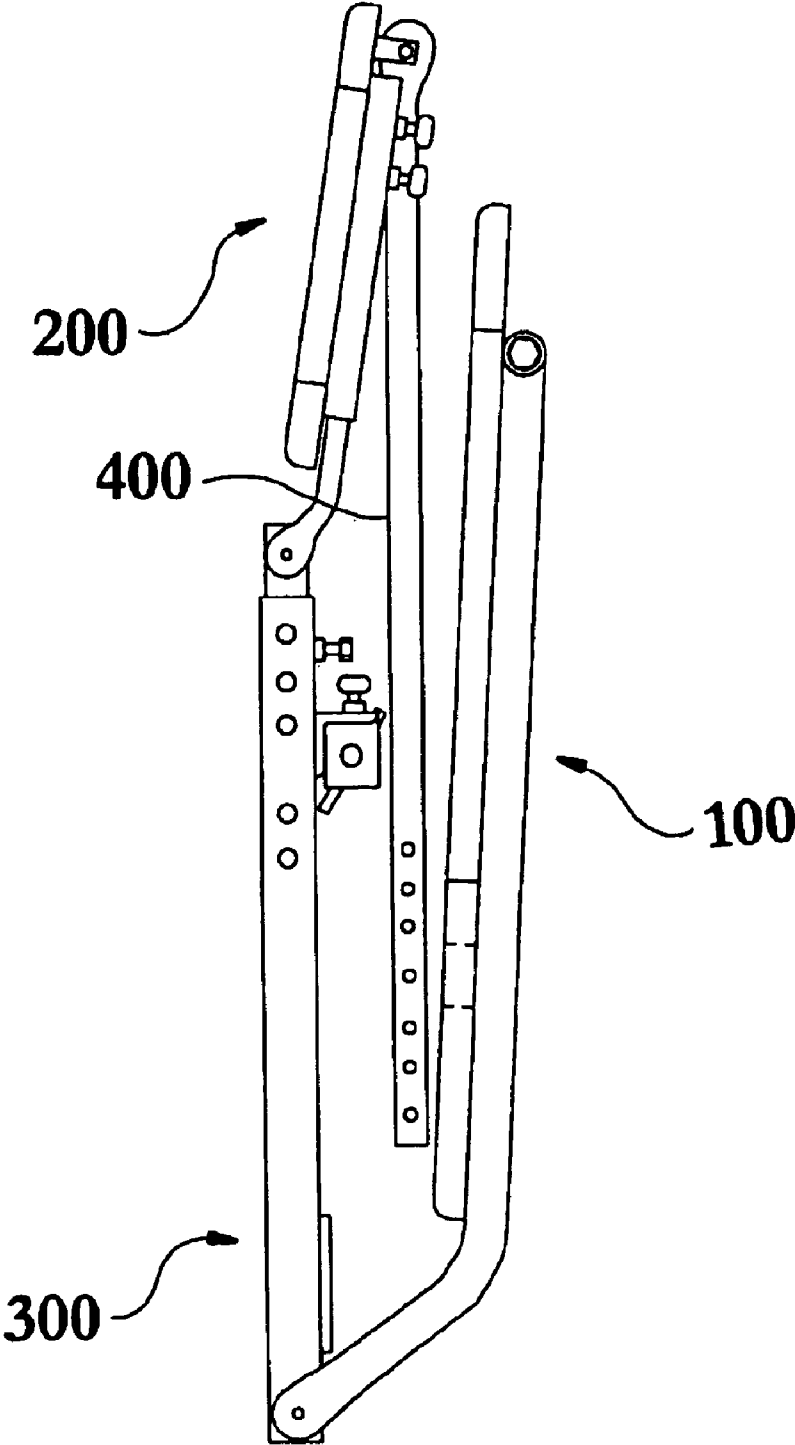

FIG. 7

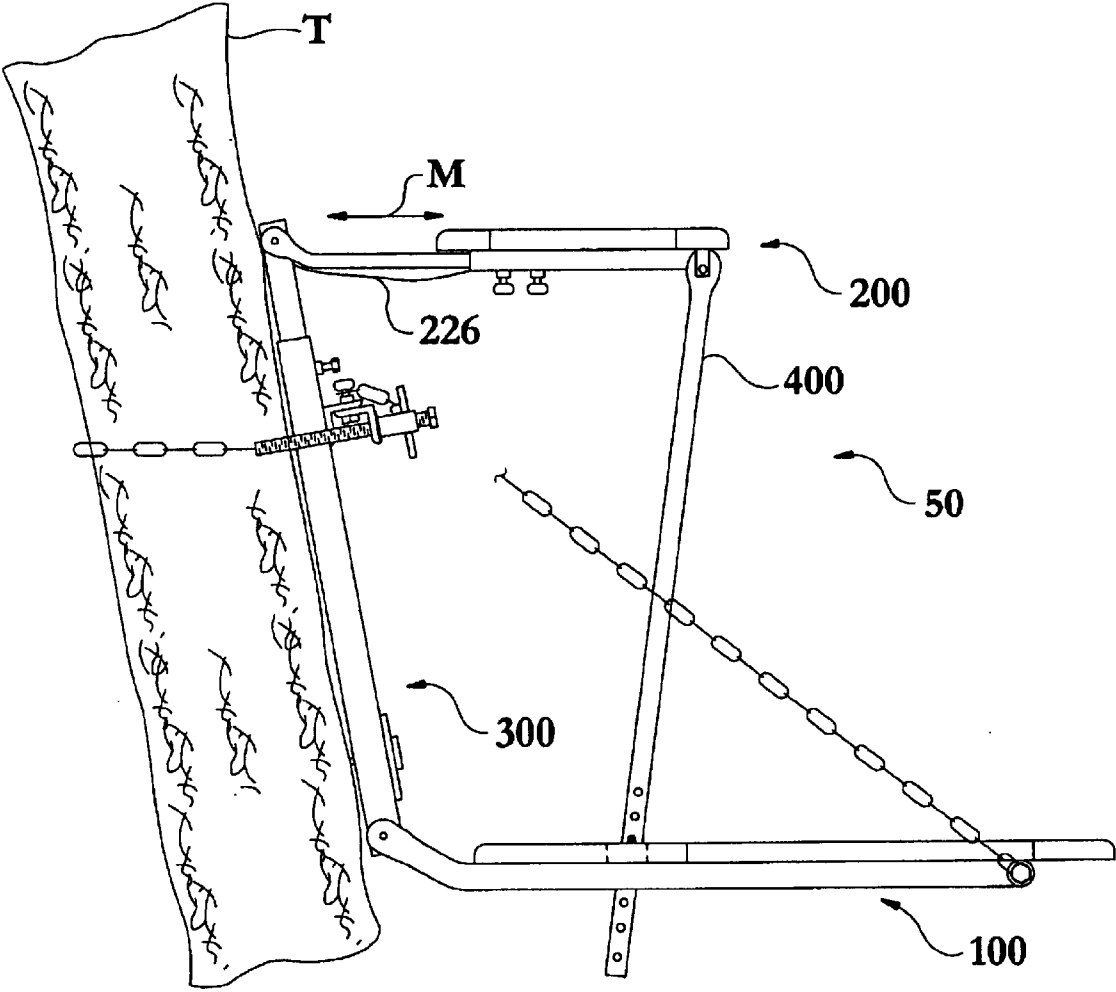

FIG. 8

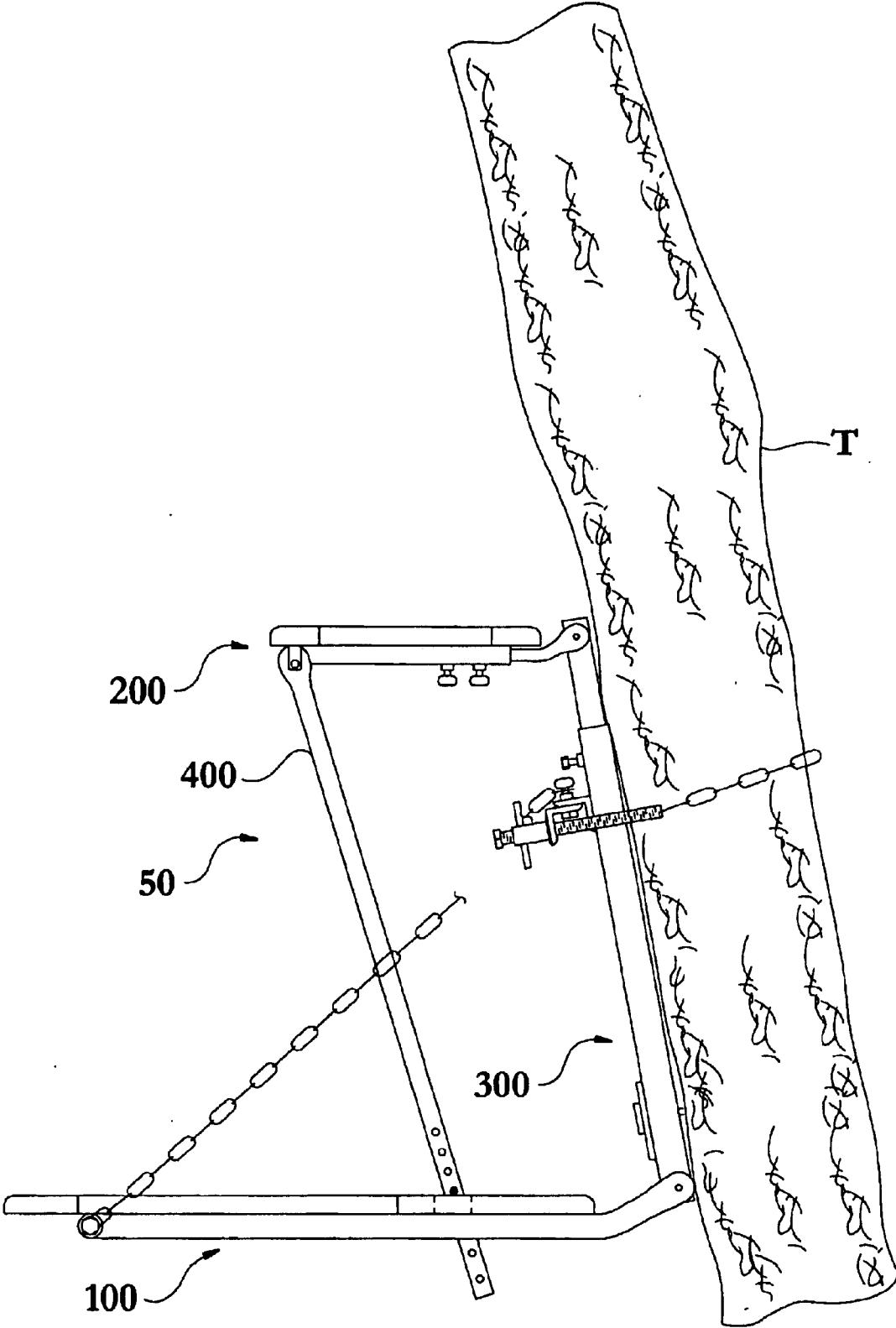

FIG. 9

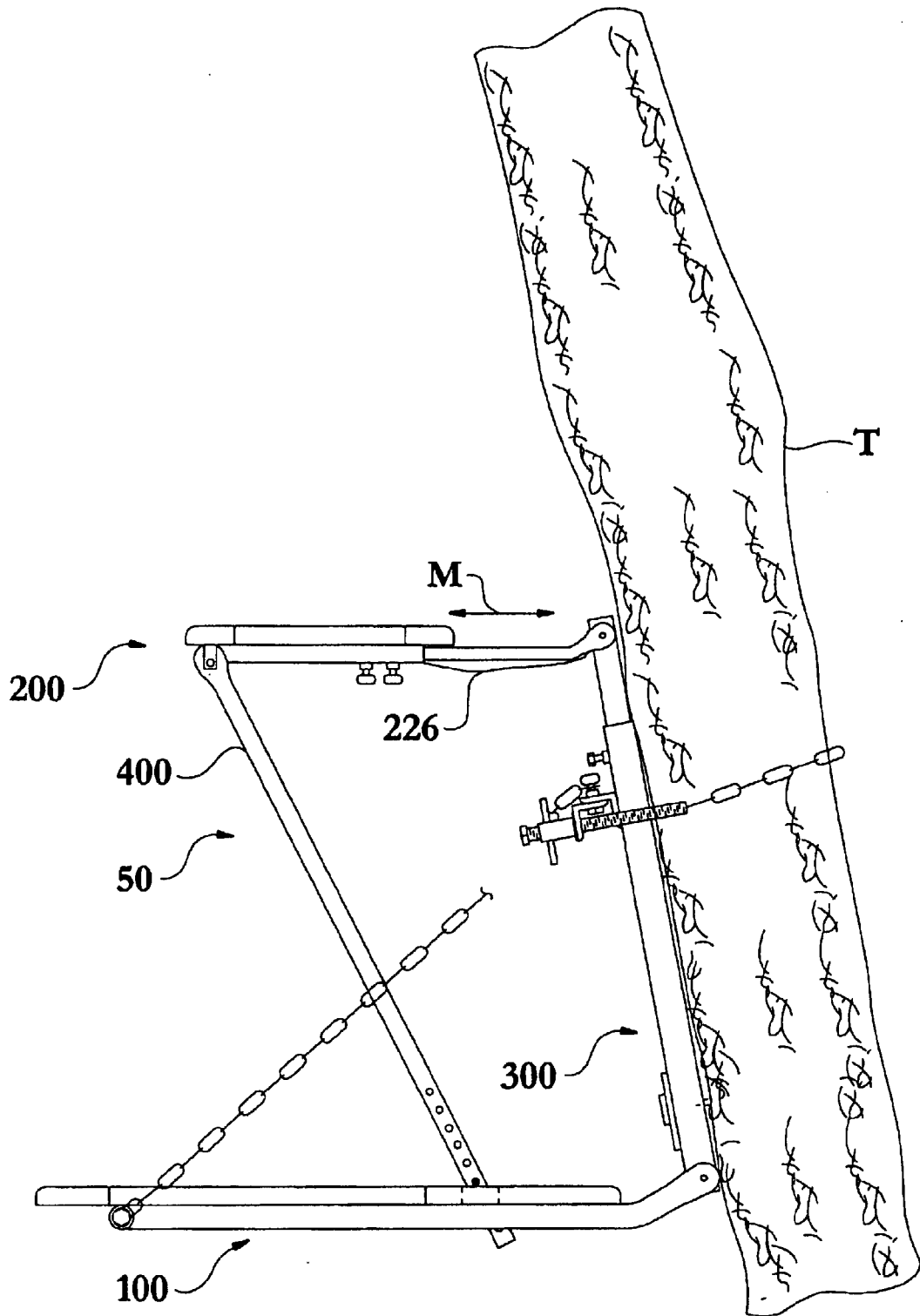

FIG. 10

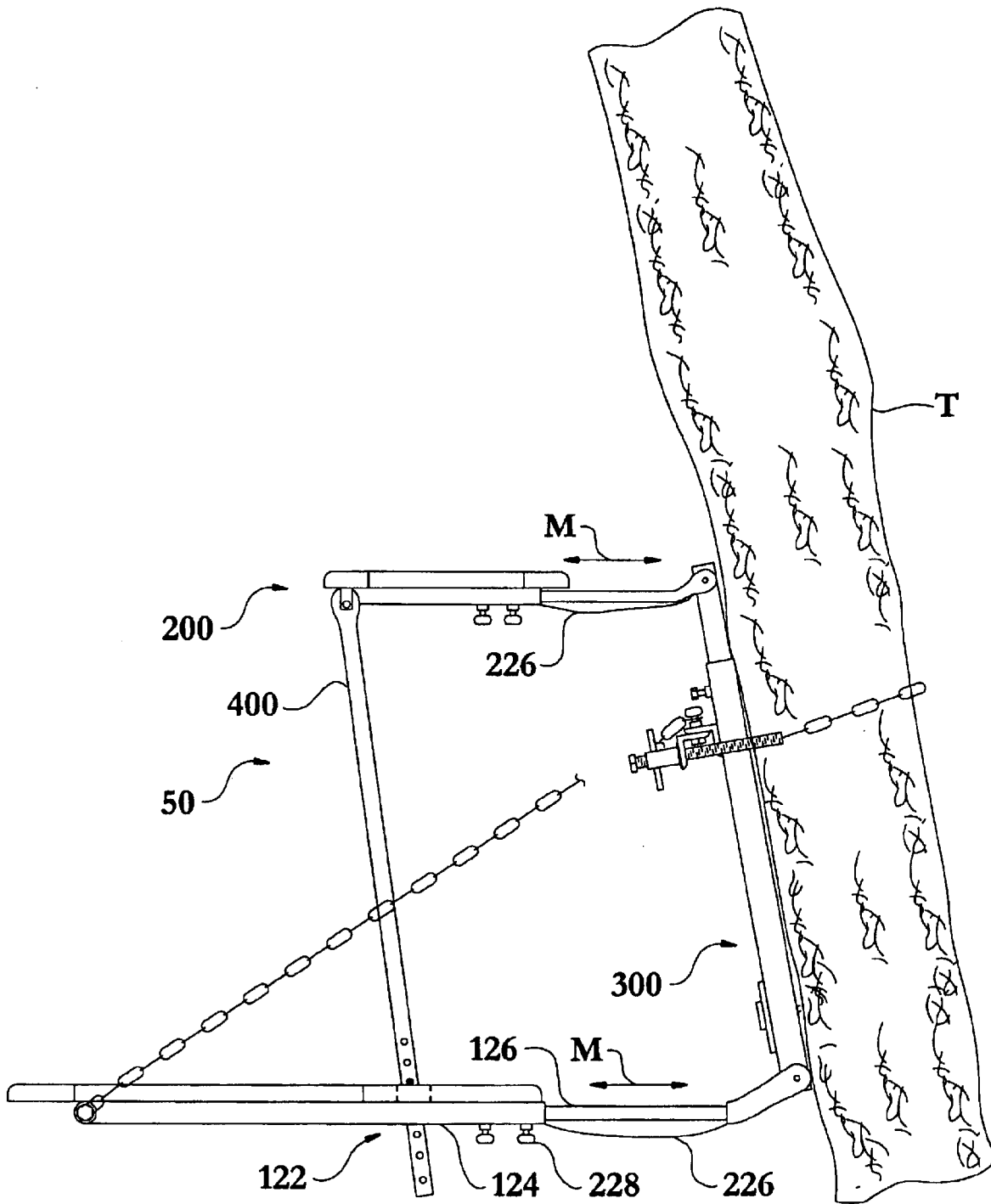

FIG. 11

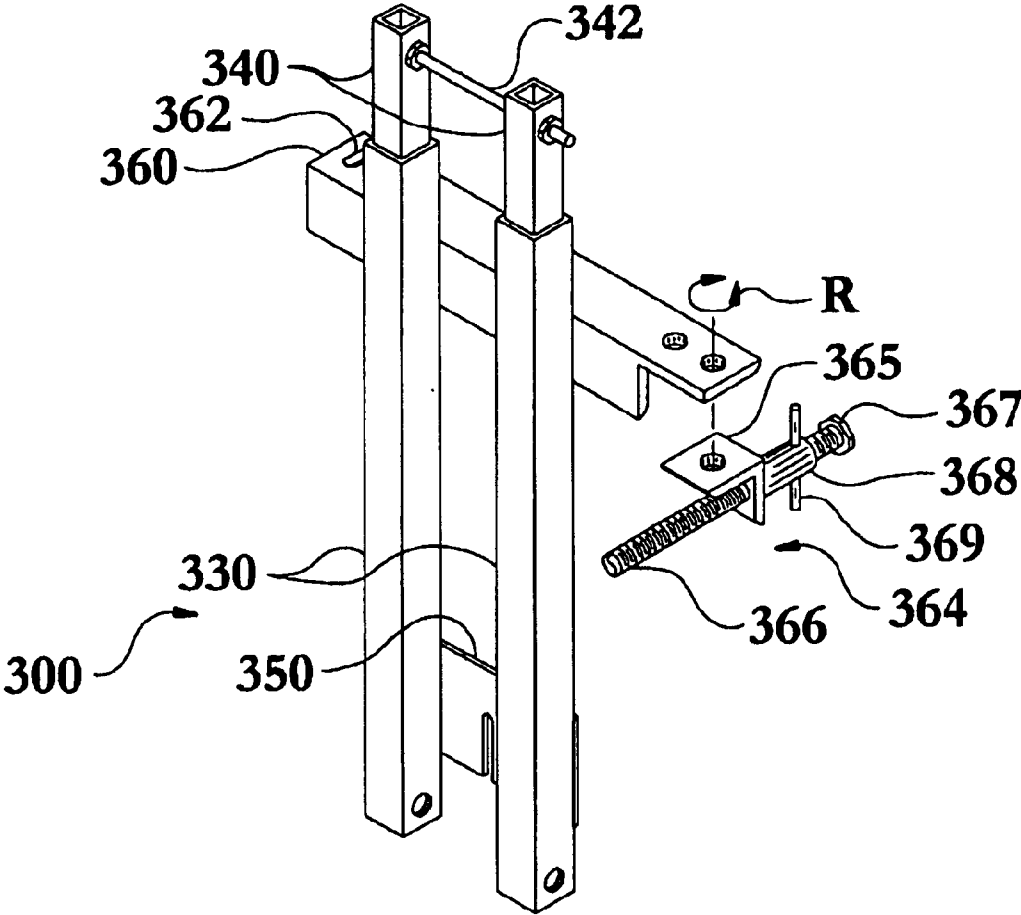

FIG. 12

1

**PORTABLE TREE STAND HAVING SEATING
AND STANDING PLATFORMS ADJUSTABLE
TO TREE ANGLE**

TECHNICAL FIELD

The present invention relates to the field tree stands utilized by hunters and sportsmen; and particularly to a portable tree stand for use with non-vertical trees whereby the standing and seating platforms may remain parallel and may be adjustable.

BACKGROUND OF THE INVENTION

The use of tree stands by sportsmen is well known in the prior art prior art tree stands have basically consisted of familiar, expected, and obvious structural configurations designed to fulfill a particular need or requirement. Very few prior art tree stands have addressed the issues surrounding the fact that tree stands are generally not installed on perfectly vertical trees. Such installations of conventional tree stands in non-vertical trees illustrate the myriad of issues that the prior art has left unsolved. A majority of these issues are very dangerous given that most tree stands are used during hunting.

The portable tree stand of the present invention substantially departs from the conventional concepts and designs of the prior art, and in so doing provides an apparatus developed for offering a lightweight portable tree stand that securely attaches to virtually any tree in a quick and easy fashion, while providing improved safety via adjustable seating and standing platforms. While some of the prior art devices attempted to improve the state of the art, none have achieved the beneficial attributes of the present invention. With these capabilities taken into consideration, the instant invention addresses many of the shortcomings of the prior art and offers significant benefits heretofore unavailable. Further, none of the known prior art, taken either singly or in combination, is seen to describe the instant invention as claimed.

SUMMARY OF INVENTION

In its most general configuration, the present invention advances the state of the art with a variety of new capabilities and overcomes many of the shortcomings of prior devices in new and novel ways. In its most general sense, the present invention overcomes the shortcomings and limitations of the prior art in any of a number of generally effective configurations. The instant invention demonstrates such capabilities and overcomes many of the shortcomings of prior methods in new and novel ways.

In one of the simplest configurations, the portable tree stand of the present invention is designed to be releasably secured to a non-vertical tree. It includes a standing platform, a seating platform, a mounting structure, and a seat support post that maintains a predetermined angular relationship between the standing platform and the seating platform.

The standing platform has a standing platform deck, at least one standing platform support, a support post receiver, and at least one platform retainer releasably secured to the standing platform. The seating platform has a seating platform deck, a seating support assembly, and a support post mount. The mounting structure has a mounting chain and an attachment member to releasably secure the platform retainer and the mounting chain to the mounting structure.

2

The seating platform assembly and standing platform are rotably connected to the mounting structure. Additionally, the attachment member is connected to the mounting structure and includes a chain tightening assembly attached to the mounting chain and a mounting chain receiver slot for releasably receiving the mounting chain encircling the tree. The mounting chain and chain tightening assembly may impart a tensile load on the mounting chain to grip the tree. Lastly, the seat support post has a proximal end and a distal end, wherein the seat support post is rotably connected to the support post mount substantially near the distal end and the proximal end is adjustably received by the support post receiver.

The unique construction and assembly of these components enable the standing platform deck and the seating platform deck to remain in a predetermined angular relationship despite a non-orthogonal relationship between the mounting structure and the standing platform deck or the seating platform deck. The configuration of the seat support post relative to the seating platform and the standing platform creates a parallelogram support that may act to keep the seating platform and the standing platform in any predetermined angular relationship. For example, if the seat support post were adjusted to give a slightly upwards tilt to the seating platform relative to the standing platform, a subsequent adjustment of the platform retainer would change the angulation of the seating platform and the standing platform relative to the tree or ground, but the slight upward tilt of the seating platform relative to the standing platform would be maintained. Additionally, the seat support post may be formed to have a plurality of adjustment receivers designed to cooperate with an adjustment pin. This configuration permits a user to quickly and easily adjust the position of the seating platform.

The seat support post may be formed to be telescoping, or have at least one hinged joint, to facilitate compact storage of the apparatus. The standing platform supports may be bent, or formed, to allow for more compact storage when folded. The standing platform supports of the present embodiment are simply bolted to the mounting structure proximal end, thereby ensuring a reliable connection that is easy to rotate.

The seating platform includes the seating platform deck, the seating platform assembly, and the support post mount. The seating platform deck may be constructed and configured in much the same way as the standing platform deck. The seating support assembly may include at least one receiver attached to the seating platform deck and at least one mount rotably attached to the mounting structure. The at least one receiver and the at least one mount are formed to cooperate with each other such that the seating platform deck and the at least one receiver may slide away from the mounting structure on the at least one mount.

One knowledgeable in the field of tree stands will recognize the functional significance of this novel feature, as tree stands are very rarely installed on perfectly vertical trees. Conventional tree stands have often not facilitated installation on the forward leaning side of a tree thereby greatly limiting the utility, as, for instance, a forward leaning tree greatly reduces the user's seating area. The user would have to lean forward to accommodate the sloping tree, thereby causing great discomfort, and potential safety issues, during the long-hours spent in the tree stand. Fortunately, the sliding seating platform deck of the present invention alleviates such problems. As previously mentioned, the seating platform deck and the at least one receiver may slide away from the mounting structure on the at least one mount,

thereby moving the user's seating position away from the tree and permitting the user to sit upright.

A further embodiment incorporates at least one adjustable standing platform support. The at least one adjustable standing platform support allows the standing platform deck to move away from the mounting structure. This feature is particularly useful in the situation of a forward leaning tree, as described above, where the seating platform deck has been moved away from the mounting structure thereby reducing the amount of foot room on the standing platform. Such an adjustable standing platform support permits the user to adjust the standing platform deck in proportion to the seating platform deck, thereby maintaining the same amount of foot room regardless of the adjustments that must be made to accommodate mounting the apparatus in non-vertical trees. The at least one adjustable platform support may include a first member that is slideably received onto a second member connected to the support structure.

The receiver and the mount may be configured in any manner that permits the seating platform deck to be relocated away from the mounting structure. The mount may be bent, or formed, to allow for more compact storage when folded. The mounts may be simply bolted to the mounting structure distal end thereby ensuring a reliable connection that is easy to rotate.

The mounting structure is connected to the at least one standing platform support and to the at least one seating support mount. The mounting structure may include at least one primary support and at least one secondary support, which may easily cooperate with each other to allow adjustability in the distance between the seating platform and the standing platform. A support interconnector may be added to increase the rigidity of the apparatus, as well as serve as a mounting point for the seat support mounts. Additionally, the mounting structure may include a mounting plate, most commonly attached to each of the primary supports, to increase the rigidity of the apparatus and provide a location for engaging a tree screw that may be secured to the tree.

The mounting structure also includes a mounting chain, ultimately secured to the attachment member. The attachment member is rigidly attached to the mounting structure, and in one embodiment, to each of the primary supports. The attachment member serves as a convenient and flexible location to releasably secure the mounting chain and the at least one platform retainer. The attachment member is formed with a mounting chain receiver slot, sized and configured to cooperate with the mounting chain. The receiver slot permits one of the numerous chain links to slide into the receiver thereby blocking entry of an adjacent chain link, so that the user may easily wrap the mounting chain around the tree and engage the receiver slot. The chain tightening assembly may then be used to impart a tensile load on the mounting chain to lock the apparatus to the tree.

The chain tightening assembly may include a mounting bracket, a threaded rod, a rod limiter, a coupling having a plurality of gripping studs, and a chain interface. The mounting bracket acts to rotably join the other components of the chain tightening assembly to the attachment member. The coupling is threadedly engaged with the threaded rod and the plurality of gripping studs permit a user to apply torque on the coupling thereby imparting more tensile force on the mounting chain through the threaded rod and the chain interface. The coupling is sized such that it is retained by the mounting bracket, and not capable of passing through the hole formed in the mounting bracket for the threaded rod. Additionally, the threaded rod has a rod limiter so that

the threaded rod is incapable of passing through the coupling. Therefore, as the user applies force to the plurality of gripping studs the coupling rotates, thereby causing the threads of the coupling to travel the threads of the threaded rod, moving the threaded rod and tightening the mounting chain. The chain tightening assembly of the present invention may be used to impart at least hundreds of pounds of tensile force on the chain, thereby ensuring a solid grip on the tree. The mounting chain may be joined to the threaded rod via the chain interface, which may be a rigid connection, such as a simple weld. The mounting bracket rotates, to allow the chain tightening assembly to rotate and accommodate trees of varying diameters. This rotation allows the first end of the mounting chain to remain coaxial with the threaded rod no matter what the diameter of the tree, thereby transferring the tensile load to the mounting chain in the most effective manner.

Overall, the instant invention advances the art by allowing, among other features, sliding adjustment of both the seating platform and standing platform, thus allowing the tree stand to be easily and safely used in trees that may be substantially vertical, or in trees with an angular lean.

BRIEF DESCRIPTION OF THE DRAWINGS

Without limiting the scope of the present invention as claimed below and referring now to the drawings and figures:

FIG. 1 is a side elevation view of a portable tree stand constructed according to the present invention;

FIG. 2 is a front elevation view of a portable tree stand constructed according to the present invention;

FIG. 3 is a top plan view of a portable tree stand constructed according to the present invention;

FIG. 4 is a top plan view of a portable tree stand, with the standing platform deck and the seating platform deck removed for clarity, constructed according to the present invention;

FIG. 5 is an elevated perspective view of the mounting structure constructed according to the present invention;

FIG. 6 is a side elevation view of a portable tree stand constructed according to the present invention;

FIG. 7 is a side elevation view of a portable tree stand constructed according to the present invention in a collapsed, or folded, configuration;

FIG. 8 is a side elevation view of a portable tree stand, mounted to a backward leaning tree, constructed according to the present invention;

FIG. 9 is a side elevation view of a portable tree stand, mounted to a forward leaning tree, constructed according to the present invention;

FIG. 10 is a side elevation view of a portable tree stand, mounted to a forward leaning tree, constructed according to the present invention;

FIG. 11 is a side elevation view of a portable tree stand, mounted to a forward leaning tree, constructed according to the present invention; and

FIG. 12 is an elevated perspective view of the mounting structure constructed according to the present invention.

Also, in the various figures and drawings, the following reference symbols and letters are used to identify the various elements described herein below in connection with the several figures and illustrations: T, R, and M.

DETAILED DESCRIPTION OF THE INVENTION

The portable tree stand of the instant invention enables a significant advance in the state of the art. The preferred

5

embodiments of the apparatus accomplish this by new and novel arrangements of elements and methods that are configured in unique and novel ways and which demonstrate previously unavailable but preferred and desirable capabilities. The detailed description set forth below in connection with the drawings is intended merely as a description of the presently preferred embodiments of the invention, and is not intended to represent the only form in which the present invention may be constructed or utilized. The description sets forth the designs, functions, means, and methods of implementing the invention in connection with the illustrated embodiments. It is to be understood, however, that the same or equivalent functions and features may be accomplished by different embodiments that are also intended to be encompassed within the spirit and scope of the invention.

The portable tree stand **50** of the present invention is designed to be releasably secured to a non-vertical tree and includes a standing platform **100**, a seating platform **200**, a mounting structure **300**, and a seat support post **400** that maintains a predetermined angular relationship between the standing platform **100** and the seating platform **200**, as seen in FIG. 1.

The standing platform **100** has a standing platform deck **110**, at least one standing platform support **120**, a support post receiver **112**, and at least one platform retainer **130** having a proximal end **132** and a distal end **134** wherein the proximal end **132** is releasably secured to the standing platform **100**, as illustrated best in FIG. 6. The seating platform **200** has a seating platform deck **210**, a seating support assembly **220**, and a support post mount **230**, as seen in FIG. 2. The mounting structure **300** has a proximal end **302**, a distal end **304**, a mounting chain **310** having a first end **312** and a second end **314**, and an attachment member **360** to releasably secure the at least one platform retainer **130** distal end **134** and the mounting chain **310** to the mounting structure **300**, seen best in FIG. 2 and FIG. 5. The seating platform assembly **200** is rotably connected substantially near the distal end **304** of the mounting structure **300** and the at least one standing platform support **120** is rotably connected substantially near the proximal end **302** of the mounting structure **300**. Additionally, the attachment member **360** is connected between the proximal end **302** and the distal end **304** and includes a chain tightening assembly **364** attached to the mounting chain **310** at the first end **312** and further includes a mounting chain receiver slot **362** for releasably receiving the mounting chain **310** upon encircling the tree T. The chain tightening assembly **364** may impart a tensile load on the mounting chain **310** thereby gripping the tree T. Lastly, the seat support post **400** has a proximal end **402** and a distal end **404**, wherein the seat support post **400** is rotably connected to the support post mount **230** substantially near the distal end **404** and the proximal end **402** is adjustably received by the support post receiver **112**. The unique construction and assembly of these components enable the standing platform deck **110** and the seating platform deck **210** to remain in a predetermined angular relationship despite a non-orthogonal relationship between the mounting structure **300** and the standing platform deck **110** or the seating platform deck **210**.

Now, referring back to the standing platform **100**, it may be constructed of any number of materials and configured in a number of ways. In one particular embodiment, the standing platform deck **110** is constructed of weather-resistant plywood, or similar oriented strand board type material. Alternatively, one with skill in the art can appreciate that the standing platform deck **110** may be constructed of expanded metal grating and composite decking type products.

6

Similarly, the standing platform support **120** may be constructed of any number of materials and configured in a number of ways. For example, in the embodiments illustrated in FIG. 1 through FIG. 11 the standing platform support **120** consists of two support members each rotably attached to the mounting structure proximal end **302**. In this particular embodiment the standing platform supports **120** are constructed of bent $\frac{3}{4}$ " electrical metallic tubing (EMT). Such EMT based construction facilitates the lightweight corrosion-resistant construction and low cost of the present invention. Alternatively, one with skill in the art can appreciate that the standing platform supports **120** may be constructed of any shape tubing, whether it is metallic, plastic, or composite. The standing platform supports **120** may be bent, or formed, as seen in FIG. 7, to allow for more compact storage when folded. The standing platform supports **120** of the present embodiment are simply bolted to the mounting structure proximal end **302** thereby ensuring a reliable connection that is easy to rotate.

The at least one platform retainer **130** acts to transfer a portion of the load on the standing platform **100** to the mounting structure **300**. The embodiments illustrated in FIG. 1 through FIG. 11 illustrate the at least one platform retainer **130** as a chain, however one with skill in the art can appreciate that alternative devices, such as cable, may be used. Chain is the preferred material because it provides for easy adjustability. For instance, the chain may be easily attached to the attachment member **360** by a chain retainer **372**, often a thumb-screw or wing nut assembly, which simply passes through a link in the chain, as seen in FIG. 6. Therefore, a user may easily adjust the angle of the standing platform **100** while always having a safe and secure attachment. The chain preferably has elastomeric coated links to reduce the likelihood of noise and to reduce the possibility of corrosion.

Now moving on to the seating platform **200**, it consists of the seating platform deck **210**, the seating platform assembly **220**, and the support post mount **230**, as seen in FIG. 2. The seating platform deck **210** may be constructed and configured in much the same way as the previously discussed standing platform deck **110**. The seating support assembly **220** may include at least one receiver **222** attached to the seating platform deck **210** and at least one mount **224** rotably attached to the mounting structure **300**. The at least one receiver **222** and the at least one mount **224** are formed to cooperate with each other such that the seating platform deck **210** and the at least one receiver **222** may slide away from the mounting structure **300** on the at least one mount **224**, as seen in FIG. 4. The direction of motion M of the seating platform deck **210** is illustrated well in FIG. 8.

The functional significance of this novel feature is illustrated in FIG. 8 through FIG. 11. As one knowledgeable in the field of tree stands will recognize, tree stands are very rarely installed on perfectly vertical trees. The apparatus **50** is shown installed on a rearward leaning (relative to the stand) tree in FIG. 8. Alternatively, the apparatus **50** is shown installed on a forward leaning (relative to the stand) tree in FIG. 9 through FIG. 11. Conventional tree stands have often not facilitated installation on a forward leaning tree thereby greatly limiting their utility. For instance, the forward leaning tree of FIG. 9 greatly reduces the user's seating area. The user would have to lean forward to accommodate the sloping tree, thereby causing great discomfort, and potential safety issues, during the long-hours spent in the tree stand. Fortunately, the sliding seating platform deck **210** of the present invention alleviates such problems, as illustrated in FIG. 10. As previously

mentioned, the seating platform deck **210** and the at least one receiver **222** may slide away from the mounting structure **300** on the at least one mount **224**, thereby moving the user's seating position away from the tree and permitting the user to sit upright, as seen in FIG. **8**. The travel length of the seating platform deck **210** may be limited in a number of ways. In one embodiment this safety feature incorporates a translation limiter **226** in the form of at least one wire secured at one end to the mounting structure **300** and secured at the opposing end to the seating platform deck **210** or the at least one receiver **222**. Alternative embodiments of the translation limiter **226** may feature structures built into the receiver **222** or the mount **224** to limit the travel. Additionally, the at least one receiver **222** and the at least one mount **224** may be releasably fixed with respect to one another with at least one locking device **228**, seen in FIG. **6**. The at least one locking device **228** may include simple thumb screws that pass through the at least one receiver **222** and engage the at least one mount **224**.

A further embodiment incorporates at least one adjustable standing platform support **122**, as seen in FIG. **11**. The at least one adjustable standing platform support **122** allows the standing platform deck **110** to move away from the mounting structure **300**. This feature is particularly useful in the situation described above, and illustrated in FIG. **10**, where the seating platform deck **210** has been moved away from the mounting structure **300**, thereby reducing the amount of foot room on the standing platform **100**. Referring again to FIG. **11**, the adjustable standing platform support **122** permits the user to adjust the standing platform deck **110** in proportion to the seating platform deck **200**, thereby maintaining the same amount of foot room regardless of the adjustments that must be made to accommodate mounting the apparatus **50** in non-vertical trees. As seen in FIG. **11**, the at least one adjustable platform support **122** may include a first member **124** that is slideably received onto a second member **126** that is connected to the support structure **300**. This standing platform **100** embodiment may incorporate the same translation limiters **226** and materials of construction discussed above regarding the seating platform **200**.

As with the standing platform support **122**, the receiver **222** and the mount **224** may be constructed of EMT. Such construction is lightweight, corrosion-resistant, and offers low material and fabrication costs. However, one with skill in the art can appreciate that the receiver **222** and the mount **224** may be constructed of any shape member or tubing, whether it is metallic, plastic, or composite. Additionally, the receiver **222** and the mount **224** are not limited to the telescoping arrangement illustrated in the figures, they may be configured in any manner that permits the seating platform deck to be relocated away from the mounting structure **300**. The mount **224** may be bent, or formed, as seen in FIG. **7**, to allow for more compact storage when folded. Additionally, the mounts **224** of the present embodiment are simply bolted to the mounting structure distal end **304** thereby ensuring a reliable connection that is easy to rotate.

Next, the mounting structure **300**, best illustrated in FIG. **5** and FIG. **12**, is connected at the proximal end **302** to the at least one standing platform support **120**, and is connected at the distal end **304** to the at least one seating support mount **224**, as seen in FIG. **2**. The mounting structure **300** may include at least one primary support **330** and at least one secondary support **340**. The embodiment illustrated in FIG. **5** and FIG. **12** shows the at least one primary support **330** and the at least one secondary support **340** configured in complementary shapes and sizes so that they may easily cooperate with each other thereby introducing adjustability

in the distance between the seating platform **200** and the standing platform **100**. In one embodiment the secondary supports **340** slide into the primary supports **330**, each made of tube steel, thereby offering low material and fabrication costs. One with skill in the art can appreciate that the primary and secondary supports **330**, **340** may be constructed of any shape member or tubing, whether it is metallic, plastic, or composite. Additionally, the primary and secondary supports **330**, **340** are not limited to the telescoping arrangement illustrated in the figures. They may be configured in any manner that permits the seating platform **200** to be adjusted nearer to, or farther away from, the standing platform **100**. The apparatus **50** may include a plurality of locking devices **380** to releasably fix the relationship between the at least one primary support **330** and the at least one secondary support **340**. The plurality of locking devices **380** may include setscrews or wing nuts that extend through the primary support **330** to engage the secondary support **340**, or may consist of pins that extend through cooperating recesses formed in the primary support **330** and the secondary support **340**, as seen in FIG. **6**.

A support interconnector **342**, as seen in FIG. **5**, may be added to increase the rigidity of the apparatus **50**, as well as serve as a mounting point for the seat support mounts **224**. The support interconnector **342** may be formed of a threaded rod extending through each of the secondary supports **340**. Additionally, the mounting structure **300** may include a mounting plate **350**, most commonly attached to each of the primary supports **330**, to increase the rigidity of the apparatus **50** and provide a location for engaging a tree screw **320** that may be secured to the tree.

The mounting structure **300** also includes a mounting chain **310** having a first end **312** and a second end **314**. The mounting chain **310** is ultimately secured to the attachment member **360**. The attachment member **360** is rigidly attached to the mounting structure **300**, and more particularly in one embodiment, to each of the primary supports **330**, as seen in FIG. **5**. This rigid connection may be made using virtually any mechanical joining means, however the connection is welded in a preferred embodiment. The attachment member **360** serves as a convenient and flexible location to releasably secure the mounting chain **310** and the at least one platform retainer **130**. The attachment member **360** is formed with a mounting chain receiver slot **362** sized and configured to cooperate with the mounting chain **310**. The receiver slot **362** permits one of the numerous chain links to slide into the receiver thereby blocking entry of an adjacent chain link. As such, the user may easily wrap the mounting chain **310** around the tree and engage the receiver slot **362**. The chain tightening assembly **364** may then be used to impart a tensile load on the mounting chain **310**, thereby locking the apparatus **50** to the tree.

The chain tightening assembly **364** may include a mounting bracket **365**, a threaded rod **366**, a rod limiter **367**, a coupling **368** having a plurality of gripping studs **369**, and a chain **20** interface **370**, as seen in FIG. **5** and FIG. **12**. The mounting bracket **365** acts to rotably join the other components of the chain tightening assembly **364** to the attachment member **360**. The mounting bracket **365** may be formed to receive the treaded rod **366**. The coupling **368** is threadedly engaged with the threaded rod **366** and the plurality of gripping studs **369** permit a user to apply more torque on the coupling **368** thereby imparting more tensile force on the mounting chain **310** through the threaded rod **366** and the chain interface **370**. The coupling **368** is sized such that it is retained by the mounting bracket **365**, and not capable of passing through the hole formed in the mounting bracket

365 for the threaded rod **366**. Additionally, the threaded rod **365** has a rod limiter **367** so that the threaded rod **366** is incapable of passing through the coupling **368**. Therefore, as the user applies force to the plurality of gripping studs **369** the coupling **368** rotates thereby causing the threads of the coupling to travel the threads of the threaded rod **366**, moving the threaded rod **366** and tightening the mounting chain **310**. The chain tightening assembly **364** of the present invention may be used to impart at least hundreds of pounds of tensile force on the chain, thereby ensuring a solid grip on the tree. The mounting chain **310** may be joined to the threaded rod **366** via the chain interface **370**, which may be a rigid connection, such as a simple weld, such that the use of a turning coupling **368** on a threaded rod **366**, as seen in FIGS. **5**, **6**, and **8** through **12**, tends to minimize any turning effect on the threaded rod **366**. The rotatable mounting bracket **365** rotates, as indicated by rotation indicator R in FIG. **5** and FIG. **12**, to allow the chain tightening assembly **364** to rotate and accommodate trees of varying diameters. This rotation allows the first end **312** of the mounting chain **310** to remain coaxial with the threaded rod **366** no matter what the diameter of the tree, thereby transferring the tensile load to the mounting chain **310** in the most effective manner.

The attachment member **360** and the mounting bracket **365** are constructed with common angle iron in the illustrated embodiment. Such construction is extremely strong, lightweight, and offers low material and fabrication costs. However, one with skill in the art can appreciate that the attachment member **360** and the mounting bracket **365** may be constructed of structural members of virtually any shape, whether it is metallic, plastic, or composite.

Lastly, the seat support post **400** may be constructed of EMT, preferably $\frac{3}{4}$ " or 1", or any shape tubing, whether it is metallic, plastic, or composite. Additionally, the seat support post **400** may be formed to have a plurality of adjustment receivers **410** designed to cooperate with an adjustment pin **420**. This configuration permits a user to quickly and easily adjust the position of the seating platform **200**. The configuration of the seat support post **400** relative to the seating platform **200** and the standing platform **100**, creates a parallelogram support that may act to keep the seating platform **200** and the standing platform **100** in any predetermined angular relationship. For example, if the seat support post **400** were adjusted to give a slightly upwards tilt to the seating platform **200** relative to the standing platform **100**, a subsequent adjustment of the platform retainer **130** would change the angulation of the seating platform **200** and the standing platform **100** relative to the tree or ground, but the slight upward tilt of the seating platform **200** relative to the standing platform **100** would be maintained. Additionally, the seat support post **400** may be formed to be telescoping, or have at least one hinged joint, to facilitate compact storage of the apparatus **50**.

Numerous alterations, modifications, and variations of the preferred embodiments disclosed herein will be apparent to those skilled in the art and they are all anticipated and contemplated to be within the spirit and scope of the instant invention. For example, although specific embodiments have been described in detail, those with skill in the art will understand that the preceding embodiments and variations can be modified to incorporate various types of substitute and or additional or alternative materials, relative arrangement of elements, and dimensional configurations. Accordingly, even though only few variations of the present invention are described herein, it is to be understood that the practice of such additional modifications and variations and the equivalents thereof, are within the spirit and scope of the

invention as defined in the following claims. The corresponding structures, materials, acts, and equivalents of all means or step plus function elements in the claims below are intended to include any structure, material, or acts for performing the functions in combination with other claimed elements as specifically claimed.

I claim:

1. A portable tree stand designed to be releasably secured to a non-vertical tree, comprising:
 - a standing platform having a standing platform deck, at least one standing platform support, a support post receiver, and at least one platform retainer having a retainer proximal end and a retainer distal end wherein the retainer proximal end is releasably secured to the standing platform;
 - a seating platform having a seating platform deck, a seating support assembly, and a support post mount;
 - a mounting structure having a structure proximal end, a structure distal end, a mounting chain having a first end and a second end, and an attachment member to releasably secure the at least one platform retainer distal end and the mounting chain to the mounting structure, wherein the seating support assembly is rotably connected substantially near the structure distal end, the at least one standing platform support is rotably connected substantially near the structure proximal end, and the attachment member is connected between the structure proximal end and the structure distal end and includes a chain tightening assembly attached to the mounting chain at the first end and further includes a mounting chain receiver for releasably receiving the mounting chain upon encircling the tree whereby the chain tightening assembly may impart a tensile load on the mounting chain thereby gripping the tree; and
 - a seat support post having a post proximal end and a post distal end, wherein the seat support post is rotably connected to the support post mount substantially near the post distal end and the post proximal end is adjustably received by the support post receiver, such that the standing platform deck and the seating platform deck may remain in a predetermined angular relationship despite a non-orthogonal relationship between the mounting structure and the standing platform deck or the seating platform deck.
2. The portable tree stand of claim 1, wherein the seating support assembly includes at least one receiver attached to the seating platform deck and at least one mount rotably attached to the mounting structure, wherein the at least one receiver and the at least one mount are formed to cooperate with each other such that the seating platform deck and the at least one receiver may slide away from the mounting structure on the at least one mount.
3. The portable tree stand of claim 2, further including a translation limiter to limit the travel range of the seating platform deck and the at least one receiver.
4. The portable tree stand of claim 1, wherein the mounting structure includes at least one primary support to which the standing platform is rotably connected and at least one secondary support to which the seating platform is rotably connected, whereby the at least one primary support and the at least one secondary support are configured to cooperate with each other such that a distance between the standing platform and the seating platform is adjustable.
5. The portable tree stand of claim 1, wherein the at least one standing platform support is at least one adjustable platform support having a first member and a second member configured to cooperate thereby permitting the standing

11

platform deck to slide away from the mounting structure, and further including at least one translation limiter.

6. The portable tree stand of claim 1, wherein the chain tightening assembly includes a threaded rod having a rod limiter at a first end and attached to a chain interface at a second end, a coupling, having at least one gripping stud, threadedly engaged to the threaded rod, and a mounting bracket for receiving the threaded rod and rotably joining the assembly to the attachment member.

7. The portable tree stand of claim 1, wherein the seat support post is formed with at least one adjustment receiver sized to cooperate with an adjustment pin so as to fix the position of the seat support post in relation to the standing platform.

8. The portable tree stand of claim 1, wherein the mounting structure further includes a mounting plate that releasably connects the mounting structure to a tree screw fixed in the tree.

9. A portable tree stand designed to be releasably secured to a non-vertical tree, comprising:

a standing platform having a standing platform deck, at least one standing platform support, a support post receiver, and at least one platform retainer having a retainer proximal end and a retainer distal end wherein the retainer proximal end is releasably secured to the standing platform;

a seating platform having a seating platform deck, a seating support assembly including at least one receiver attached to the seating platform deck and at least one mount rotably attached to a mounting structure, wherein the at least one receiver and the at least one mount are formed to cooperate with each other such that the seating platform deck and the at least one receiver may slide away from the mounting structure on the at least one mount, and a support post mount;

the mounting structure having a structure proximal end, a structure distal end, a mounting chain having a first end and a second end, and an attachment member to releasably secure the at least one platform retainer distal end and the mounting chain to the mounting structure, wherein the seating support assembly is rotably connected substantially near the structure distal end, the at least one standing platform support is rotably connected substantially near the structure proximal end, and the attachment member is connected between the structure proximal end and the structure distal end and includes a chain tightening assembly attached to the mounting chain at the first end and further includes a mounting chain receiver for releasably receiving the mounting chain upon encircling the tree whereby the chain tightening assembly may impart a tensile load on the mounting chain thereby gripping the tree; and wherein the mounting structure includes at least one primary support to which the standing platform is rotably connected and at least one secondary support to which the seating platform is rotably connected, whereby the at least one primary support and the at least one secondary support are configured to cooperate with each other such that a distance between the standing platform and the seating platform is adjustable; and

a seat support post having a post proximal end and a post distal end, wherein the seat support post is rotably connected to the support post mount substantially near the post distal end and the post proximal end is adjustably received by the support post receiver, such that the standing platform deck and the seating platform deck

12

may in a predetermined angular relationship despite a non-orthogonal relationship between the mounting structure and the standing platform deck or the seating platform deck.

10. The portable tree stand of claim 9, further including a translation limiter to limit the travel range of the seating platform deck and the at least one receiver.

11. The portable tree stand of claim 9, wherein the at least one standing platform support is at least one adjustable platform support having a first member and a second member configured to cooperate thereby permitting the standing platform deck to slide away from the mounting structure, and further including at least one translation limiter.

12. The portable tree stand of claim 9, wherein the chain tightening assembly includes a threaded rod having a rod limiter at a first end and attached to a chain interface at a second end, a coupling, having at least one gripping stud, threadedly engaged to the threaded rod, and a mounting bracket for receiving the threaded rod and rotably joining the assembly to the attachment member.

13. The portable tree stand of claim 9, wherein the seat support post is formed with at least one adjustment receiver sized to cooperate with an adjustment pin so as to fix the position of the seat support post in relation to the standing platform.

14. The portable tree stand of claim 9, wherein the mounting structure further includes a mounting plate that releasably connects the mounting structure to a tree screw fixed in the tree.

15. A portable tree stand designed to be releasably secured to a non-vertical tree, comprising:

a standing platform having a standing platform deck, at least one standing platform support, wherein the at least one standing platform support is at least one adjustable platform support having a first member and a second member configured to cooperate thereby permitting the standing platform deck to slide away from a mounting structure, a support post receiver, and at least one platform retainer having a retainer proximal end and a retainer distal end wherein the retainer proximal end is releasably secured to the standing platform;

a seating platform having a seating platform deck, a seating support assembly including at least one receiver attached to the seating platform deck and at least one mount rotably attached to the mounting structure, wherein the at least one receiver and the at least one mount are formed to cooperate with each other such that the seating platform deck and the at least one receiver may slide away from the mounting structure on the at least one mount, and a support post mount;

the mounting structure having a structure proximal end, a structure distal end, a mounting chain having a first end and a second end, and an attachment member to releasably secure the at least one platform retainer distal end and the mounting chain to the mounting structure, wherein the seating support assembly is rotably connected substantially near the structure distal end, the at least one standing platform support is rotably connected substantially near the structure proximal end, and the attachment member is connected between the structure proximal end and the structure distal end and includes a chain tightening assembly attached to the mounting chain at the first end and further includes a mounting chain receiver for releasably receiving the mounting chain upon encircling the tree whereby the chain tightening assembly may impart a tensile load on the mounting chain thereby gripping the tree; and

13

wherein the mounting structure includes at least one primary support to which the standing platform is rotably connected and at least one secondary support to which the seating platform is rotably connected, whereby the at least one primary support and the at least one secondary support are configured to cooperate with each other such that a distance between the standing platform and the seating platform is adjustable; and

a seat support post having a post proximal end and a post distal end, wherein the seat support post is rotably connected to the support post mount substantially near the post distal end and the post proximal end is adjustably received by the support post receiver, such that the standing platform dock and the seating platform deck may remain in a predetermined angular relationship despite a non-orthogonal relationship between the mounting structure and the standing platform deck or the seating platform deck.

16. The portable tree stand of claim 15, further including a translation limiter to limit the travel range of the seating platform deck and the at least one receiver.

14

17. The portable tree stand of claim 15, wherein the chain tightening assembly includes a threaded rod having a rod limiter at a first end and attached to a chain interface at a second end, a coupling, having at least one gripping stud, threadedly engaged to the threaded rod, and a mounting bracket for receiving the threaded rod and rotably joining the assembly to the attachment member.

18. The portable tree stand of claim 15, wherein the seat support post is formed with at least one adjustment receiver sized to cooperate with an adjustment pin so as to fix the position of the seat support post in relation to the standing platform.

19. The portable tree stand of claim 15, wherein the mounting structure further includes a mounting plate that releasably connects the mounting structure to a tree screw fixed in the tree.

20. The portable tree stand of claim 15, further including a translation limiter to limit the travel range of the standing platform deck and the at least one receiver.

* * * * *