

(12) **United States Patent**
Burnett et al.

(10) **Patent No.:** **US 8,827,831 B2**
(45) **Date of Patent:** **Sep. 9, 2014**

(54) **GOLF CLUB HEAD HAVING A STRESS REDUCING FEATURE**

(75) Inventors: **Michael Scott Burnett**, McKinney, TX (US); **Alexander Theodore Berger**, Richardson, TX (US); **Justin Honea**, Rowlett, TX (US)

(73) Assignee: **Taylor Made Golf Company, Inc.**, Carlsbad, CA (US)

(*) Notice: Subject to any disclaimer, the term of this patent is extended or adjusted under 35 U.S.C. 154(b) by 294 days.

(21) Appl. No.: **13/542,356**

(22) Filed: **Jul. 5, 2012**

(65) **Prior Publication Data**

US 2012/0270676 A1 Oct. 25, 2012

Related U.S. Application Data

(63) Continuation-in-part of application No. 13/397,122, filed on Feb. 15, 2012, which is a continuation-in-part of application No. 12/791,025, filed on Jun. 1, 2010, now Pat. No. 8,235,844.

(51) **Int. Cl.**

A63B 53/04 (2006.01)
A63B 59/00 (2006.01)
A63B 49/06 (2006.01)

(52) **U.S. Cl.**

CPC **A63B 53/04** (2013.01); **A63B 2053/0433** (2013.01); **A63B 2053/0408** (2013.01); **A63B 2053/0412** (2013.01); **A63B 2053/0437** (2013.01); **A63B 53/0466** (2013.01); **A63B 59/0088** (2013.01); **A63B 49/06** (2013.01)
USPC **473/329**; **473/332**; **473/342**; **473/345**

(58) **Field of Classification Search**

USPC 473/324–350
See application file for complete search history.

(56) **References Cited**

U.S. PATENT DOCUMENTS

411,000 A	9/1889	Anderson
708,575 A	9/1902	Mules
727,819 A	5/1903	Mattern
819,900 A	5/1906	Martin
1,133,129 A	3/1915	Govan
1,518,316 A	12/1924	Ellingham
1,526,438 A	2/1925	Scott

(Continued)

FOREIGN PATENT DOCUMENTS

CN	2436182 Y	6/2001
CN	201353407 Y	12/2009

(Continued)

OTHER PUBLICATIONS

Office action from the U.S. Patent and Trademark office in the U.S. Appl. No. 13/401,690, dated May 23, 2012.

(Continued)

Primary Examiner — Alvin Hunter

(74) *Attorney, Agent, or Firm* — David J. Dawsey; Michael J. Gallagher; Gallagher & Dawsey Co., LPA

(57) **ABSTRACT**

A hollow golf club incorporating a stress reducing feature including at least a toe located stress reducing feature or a heel located stress reducing feature at least partially located on the skirt of the golf club head. The location and size of the stress reducing feature and their relationship to one another play a significant role in selectively increasing deflection of the face.

25 Claims, 42 Drawing Sheets

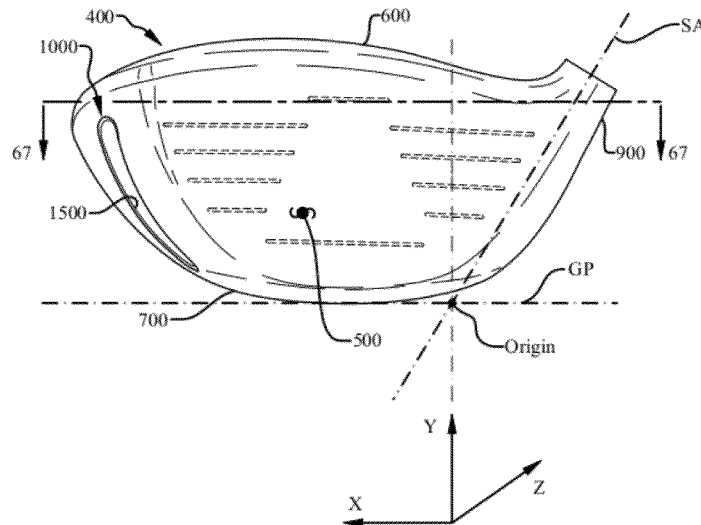

(56)

References Cited

U.S. PATENT DOCUMENTS

1,538,312	A	5/1925	Beat	D285,473	S	9/1986	Flood
1,592,463	A	7/1926	Marker	4,712,798	A	12/1987	Preato
1,658,581	A	2/1928	Tobia	4,730,830	A	3/1988	Tilley
1,704,119	A	3/1929	Buhrke	4,736,093	A	4/1988	Braly
1,705,997	A	3/1929	Quynn	4,754,974	A	7/1988	Kobayashi
1,970,409	A	8/1934	Wiedemann	4,754,977	A	7/1988	Sahm
2,004,968	A	6/1935	Young	4,762,322	A	8/1988	Molitor et al.
2,034,936	A	3/1936	Barnhart	4,787,636	A	11/1988	Honma
D107,007	S	11/1937	Cashmore	4,795,159	A	1/1989	Nagamoto
2,198,981	A	4/1940	Sullivan	4,803,023	A	2/1989	Enomoto et al.
2,214,356	A	9/1940	Wettlaufer	4,867,457	A	9/1989	Lowe
2,225,930	A	12/1940	Sexton	4,867,458	A	9/1989	Sumikawa et al.
2,328,583	A	9/1943	Reach	4,869,507	A	9/1989	Sahm
2,332,342	A	10/1943	Reach	4,881,739	A	11/1989	Garcia
2,360,364	A	10/1944	Reach	4,895,367	A	1/1990	Kajita et al.
2,375,249	A	5/1945	Richer	4,895,371	A	1/1990	Bushner
2,460,435	A	2/1949	Schaffer	4,915,558	A	4/1990	Muller
2,681,523	A	6/1954	Sellers	4,919,428	A	4/1990	Perkins
2,968,486	A	1/1961	Jackson	4,962,932	A	10/1990	Anderson
3,064,980	A	11/1962	Steiner	4,994,515	A	2/1991	Washiyama et al.
3,084,940	A	4/1963	Cissel	5,006,023	A	4/1991	Kaplan
3,085,804	A	4/1963	Pieper	5,020,950	A	6/1991	Ladouceur
3,166,320	A	1/1965	Onions	5,028,049	A	7/1991	McKeighen
3,466,047	A	9/1969	Rodia et al.	5,039,267	A	8/1991	Wollar
3,486,755	A	12/1969	Hodge	5,050,879	A	9/1991	Sun et al.
3,556,533	A	1/1971	Hollis	5,058,895	A	10/1991	Igarashi
3,589,731	A	6/1971	Chancellor	5,076,585	A	12/1991	Bouquet
3,606,327	A	9/1971	Gorman	D323,035	S	1/1992	Yang
3,610,630	A	10/1971	Glover	5,078,400	A	1/1992	Desbiolles et al.
3,652,094	A	3/1972	Glover	5,092,599	A	3/1992	Okumoto et al.
3,672,419	A	6/1972	Fischer	5,116,054	A	5/1992	Johnson
3,692,306	A	9/1972	Glover	5,121,922	A	6/1992	Harsh, Sr.
3,743,297	A	7/1973	Dennis	5,122,020	A	6/1992	Bedi
3,893,672	A	7/1975	Schonher	5,172,913	A	12/1992	Bouquet
3,897,066	A	7/1975	Belmont	5,190,289	A	3/1993	Nagai et al.
3,970,236	A	7/1976	Rogers	5,193,810	A	3/1993	Antonious
3,976,299	A	8/1976	Lawrence et al.	5,203,565	A	4/1993	Murray et al.
3,979,122	A	9/1976	Belmont	5,221,086	A	6/1993	Antonious
3,979,123	A	9/1976	Belmont	5,244,210	A	9/1993	Au
3,985,363	A	10/1976	Jepson et al.	5,251,901	A	10/1993	Solheim et al.
3,997,170	A	12/1976	Goldberg	5,253,869	A	10/1993	Dingle et al.
4,008,896	A	2/1977	Gordos	5,255,919	A	10/1993	Johnson
4,027,885	A	6/1977	Rogers	D343,558	S	1/1994	Latraverse et al.
4,043,563	A	8/1977	Churchward	5,297,794	A	3/1994	Lu
4,052,075	A	10/1977	Daly	5,301,944	A	4/1994	Koehler
4,058,934	A	11/1977	Churchward	5,316,305	A	5/1994	McCabe
4,065,133	A	12/1977	Gordos	5,318,297	A	6/1994	Davis et al.
4,076,254	A	2/1978	Nygren	5,320,005	A	6/1994	Hsiao
4,077,633	A	3/1978	Studen	5,328,176	A	7/1994	Lo
4,085,934	A	4/1978	Churchward	5,340,106	A	8/1994	Ravaris
4,121,832	A	10/1978	Ebbing	5,346,217	A	9/1994	Tsuchiya et al.
4,139,196	A	2/1979	Riley	5,385,348	A	1/1995	Wargo
4,147,349	A	4/1979	Jeghers	5,395,113	A	3/1995	Antonious
4,150,702	A	4/1979	Holmes	5,410,798	A	5/1995	Lo
4,165,076	A	8/1979	Cella	5,419,556	A	5/1995	Take
4,189,976	A	2/1980	Becker	5,421,577	A	6/1995	Kobayashi
4,193,601	A	3/1980	Reid, Jr. et al.	5,429,365	A	7/1995	McKeighen
4,214,754	A	7/1980	Zebelean	5,437,456	A	8/1995	Schmidt et al.
D256,709	S	9/1980	Reid, Jr. et al.	5,439,222	A	8/1995	Kranenberg
4,247,105	A	1/1981	Jeghers	5,441,274	A	8/1995	Clay
4,262,562	A	4/1981	MacNeill	5,447,309	A	9/1995	Vincent
D259,698	S	6/1981	MacNeill	5,449,260	A	9/1995	Whittle
4,340,229	A	7/1982	Stuff, Jr.	D365,615	S	12/1995	Shimatani
4,398,965	A	8/1983	Campau	D366,508	S	1/1996	Hutin
4,411,430	A	10/1983	Dian	5,482,280	A	1/1996	Yamawaki
4,423,874	A	1/1984	Stuff, Jr.	5,492,327	A	2/1996	Biafore, Jr.
4,431,192	A	2/1984	Stuff, Jr.	5,511,786	A	4/1996	Antonious
4,438,931	A	3/1984	Motomiya	5,518,243	A	5/1996	Redman
4,489,945	A	12/1984	Kobayashi	5,533,730	A	7/1996	Ruvang
4,527,799	A	7/1985	Solheim	D372,512	S	8/1996	Simmons
4,530,505	A	7/1985	Stuff	5,558,332	A	9/1996	Cook
D284,346	S	6/1986	Masters	D375,130	S	10/1996	Hlinka et al.
4,592,552	A	6/1986	Garber	5,564,705	A	10/1996	Kobayashi et al.
4,602,787	A	7/1986	Sugioka et al.	5,571,053	A	11/1996	Lane
4,607,846	A	8/1986	Perkins	5,582,553	A	12/1996	Ashcraft et al.
				D377,509	S	1/1997	Katayama
				5,613,917	A	3/1997	Kobayashi et al.
				D378,770	S	4/1997	Hlinka et al.
				5,616,088	A	4/1997	Aizawa et al.

(56)

References Cited

U.S. PATENT DOCUMENTS

5,620,379	A	4/1997	Borys	6,123,627	A	9/2000	Antonious
5,624,331	A	4/1997	Lo et al.	6,146,286	A	11/2000	Masuda
5,629,475	A	5/1997	Chastonay	6,149,533	A	11/2000	Finn
5,632,694	A	5/1997	Lee	6,162,132	A	12/2000	Yoneyama
5,632,695	A	5/1997	Hlinka et al.	6,162,133	A	12/2000	Peterson
D382,612	S	8/1997	Oyer	6,168,537	B1	1/2001	Ezawa
5,658,206	A	8/1997	Antonious	6,171,204	B1	1/2001	Starry
5,669,827	A	9/1997	Nagamoto	6,186,905	B1	2/2001	Kosmatka
5,683,309	A	11/1997	Reimers	6,190,267	B1	2/2001	Marlowe et al.
5,688,189	A	11/1997	Bland	6,193,614	B1	2/2001	Sasamoto et al.
5,695,412	A	12/1997	Cook	6,203,448	B1	3/2001	Yamamoto
5,700,208	A	12/1997	Nelms	6,206,789	B1	3/2001	Takeda
5,709,613	A	1/1998	Sheraw	6,206,790	B1	3/2001	Kubica et al.
5,718,641	A	2/1998	Lin	6,210,290	B1	4/2001	Erickson et al.
5,720,674	A	2/1998	Galy	6,217,461	B1	4/2001	Galy
D392,526	S	3/1998	Nicely	6,238,303	B1	5/2001	Fite
5,735,754	A	4/1998	Antonious	6,244,974	B1	6/2001	Hanberry, Jr.
D394,688	S	5/1998	Fox	6,244,976	B1	6/2001	Murphy et al.
5,746,664	A	5/1998	Reynolds, Jr.	6,248,025	B1	6/2001	Murphy et al.
5,749,795	A	5/1998	Schmidt et al. 473/350	6,254,494	B1	7/2001	Hasebe et al.
5,755,627	A	5/1998	Yamazaki et al.	6,264,414	B1	7/2001	Hartmann et al.
5,759,114	A	6/1998	Bluto et al.	6,270,422	B1	8/2001	Fisher
5,762,567	A	6/1998	Antonious	6,277,032	B1	8/2001	Smith
5,766,095	A	6/1998	Antonious	6,290,609	B1	9/2001	Takeda
5,769,737	A	6/1998	Holladay et al.	6,296,579	B1	10/2001	Robinson
5,772,527	A	6/1998	Liu	6,299,547	B1	10/2001	Kosmatka
5,776,010	A	7/1998	Helmstetter et al.	6,306,048	B1	10/2001	McCabe et al.
5,776,011	A	7/1998	Su et al.	6,325,728	B1	12/2001	Helmstetter et al.
5,785,608	A	7/1998	Collins	6,332,847	B2	12/2001	Murphy et al.
5,788,587	A	8/1998	Tseng	6,334,817	B1	1/2002	Ezawa et al.
5,798,587	A	8/1998	Lee	6,334,818	B1	1/2002	Cameron et al.
D397,750	S	9/1998	Frazetta	6,338,683	B1	1/2002	Kosmatka
RE35,955	E	11/1998	Lu	6,340,337	B2	1/2002	Hasebe et al.
5,830,084	A	11/1998	Kosmatka	6,348,012	B1	2/2002	Erickson et al.
D403,037	S	12/1998	Stone et al.	6,348,013	B1	2/2002	Kosmatka 473/329
5,851,160	A	12/1998	Rugge et al.	6,348,014	B1	2/2002	Chiu
D405,488	S	2/1999	Burrows	6,354,962	B1	3/2002	Galloway et al.
5,876,293	A	3/1999	Musty	6,364,788	B1	4/2002	Helmstetter et al.
5,885,166	A	3/1999	Shiraishi	6,368,234	B1	4/2002	Galloway
5,890,971	A	4/1999	Shiraishi	6,371,868	B1	4/2002	Galloway et al.
D409,463	S	5/1999	McMullin	6,379,264	B1	4/2002	Forzano
5,908,356	A	6/1999	Nagamoto	6,379,265	B1	4/2002	Hirakawa et al.
5,911,638	A	6/1999	Parente et al.	6,383,090	B1	5/2002	ODoherty et al.
5,913,735	A	6/1999	Kenmi	6,386,987	B1	5/2002	Lejeune, Jr.
5,916,042	A	6/1999	Reimers	6,386,990	B1	5/2002	Reyes et al.
D412,547	S	8/1999	Fong	6,390,933	B1	5/2002	Galloway et al.
5,935,019	A	8/1999	Yamamoto	6,398,666	B1	6/2002	Evans et al.
5,935,020	A	8/1999	Stites et al.	6,406,378	B1	6/2002	Murphy et al.
5,941,782	A	8/1999	Cook	6,409,612	B1	6/2002	Evans et al.
D413,952	S	9/1999	Oyer	6,425,832	B2	7/2002	Cackett et al.
5,947,840	A	9/1999	Ryan	6,434,811	B1	8/2002	Helmstetter et al.
5,954,595	A	9/1999	Antonious	6,435,977	B1	8/2002	Helmstetter et al.
5,967,905	A	10/1999	Nakahara et al.	6,436,142	B1	8/2002	Paes et al.
5,971,867	A	10/1999	Galy	6,440,008	B2	8/2002	Murphy et al.
5,976,033	A	11/1999	Takeda	6,440,009	B1	8/2002	Guibaud et al.
5,997,415	A	12/1999	Wood	6,440,010	B1	8/2002	Deshmukh
6,001,029	A	12/1999	Kobayashi	6,443,851	B1	9/2002	Liberatore
6,015,354	A	1/2000	Ahn et al.	6,458,042	B1	10/2002	Chen
6,017,177	A	1/2000	Lanham	6,458,044	B1	10/2002	Vincent et al.
6,019,686	A	2/2000	Gray	6,461,249	B2	10/2002	Liberatore
6,023,891	A	2/2000	Robertson et al.	6,464,598	B1	10/2002	Miller
6,032,677	A	3/2000	Blechman et al.	6,471,604	B2	10/2002	Hocknell et al.
6,033,318	A	3/2000	Drajan, Jr. et al.	6,475,101	B2	11/2002	Burrows
6,033,319	A	3/2000	Farrar	6,475,102	B2	11/2002	Helmstetter et al.
6,033,321	A	3/2000	Yamamoto	6,478,692	B2	11/2002	Kosmatka
6,042,486	A	3/2000	Gallagher	6,482,106	B2	11/2002	Saso
6,048,278	A	4/2000	Meyer et al.	6,491,592	B2	12/2002	Cackett et al.
6,056,649	A	5/2000	Imai	6,508,978	B1	1/2003	Deshmukh
6,062,988	A	5/2000	Yamamoto	6,514,154	B1	2/2003	Finn
6,074,308	A	6/2000	Domas	6,524,194	B2	2/2003	McCabe
6,077,171	A	6/2000	Yoneyama	6,524,197	B2	2/2003	Boone
6,083,115	A	7/2000	King	6,524,198	B2	2/2003	Takeda
6,086,485	A	7/2000	Hamada et al.	6,527,649	B1	3/2003	Neher et al.
6,089,994	A	7/2000	Sun	6,527,650	B2	3/2003	Reyes et al.
6,093,113	A	7/2000	Mertens	6,530,847	B1	3/2003	Antonious
				6,530,848	B2	3/2003	Gillig
				6,533,679	B1	3/2003	McCabe et al.
				6,547,676	B2	4/2003	Cackett et al.
				6,558,273	B2	5/2003	Kobayashi et al.

(56)

References Cited

U.S. PATENT DOCUMENTS

6,565,448	B2	5/2003	Cameron	6,887,165	B2	5/2005	Tsurumaki
6,565,452	B2	5/2003	Helmstetter et al.	6,890,267	B2	5/2005	Mahaffey et al.
6,569,029	B1	5/2003	Hamburger	D506,236	S	6/2005	Evans et al.
6,569,040	B2	5/2003	Bradstock	6,902,497	B2	6/2005	Deshmukh et al.
6,572,489	B2	6/2003	Miyamoto et al.	6,904,663	B2	6/2005	Willett et al.
6,575,845	B2	6/2003	Galloway et al.	D508,274	S	8/2005	Burrows
6,582,323	B2	6/2003	Soracco et al.	D508,275	S	8/2005	Burrows
6,592,466	B2	7/2003	Helmstetter et al.	6,923,734	B2	8/2005	Meyer
6,592,468	B2	7/2003	Vincent et al.	6,926,619	B2	8/2005	Helmstetter et al.
6,602,149	B1	8/2003	Jacobson	6,932,717	B2	8/2005	Hou et al.
6,605,007	B1	8/2003	Bissonnette et al.	6,960,142	B2	11/2005	Bissonnette et al.
6,607,452	B2	8/2003	Helmstetter et al.	6,964,617	B2	11/2005	Williams
6,612,398	B1	9/2003	Tokimatsu et al.	6,974,393	B2	12/2005	Caldwell et al.
6,616,547	B2	9/2003	Vincent et al.	6,988,960	B2	1/2006	Mahaffey et al.
6,620,056	B2	9/2003	Galloway et al.	6,991,558	B2	1/2006	Beach et al.
6,638,180	B2	10/2003	Tsurumaki	D515,165	S	2/2006	Zimmerman et al.
6,638,183	B2	10/2003	Takeda	6,994,636	B2	2/2006	Hocknell et al.
D482,089	S	11/2003	Burrows	6,994,637	B2	2/2006	Murphy et al.
D482,090	S	11/2003	Burrows	6,997,820	B2	2/2006	Willett et al.
D482,420	S	11/2003	Burrows	7,004,849	B2	2/2006	Cameron
6,641,487	B1	11/2003	Hamburger	7,004,852	B2	2/2006	Billings
6,641,490	B2	11/2003	Ellemor	7,025,692	B2	4/2006	Erickson et al.
6,648,772	B2	11/2003	Vincent et al.	7,029,403	B2	4/2006	Rice et al.
6,648,773	B1	11/2003	Evans	D520,585	S	5/2006	Hasebe
6,652,387	B2	11/2003	Liberatore	D523,104	S	6/2006	Hasebe
D484,208	S	12/2003	Burrows	7,070,512	B2	7/2006	Nishio
6,663,504	B2	12/2003	Hocknell et al.	7,070,517	B2	7/2006	Cackett et al.
6,663,506	B2	12/2003	Nishimoto et al.	7,077,762	B2	7/2006	Kouno et al.
6,669,571	B1	12/2003	Cameron et al.	7,082,665	B2	8/2006	Deshmukh et al.
6,669,576	B1	12/2003	Rice	7,097,572	B2	8/2006	Yabu
6,669,577	B1	12/2003	Hocknell et al.	7,101,289	B2	9/2006	Gibbs et al.
6,669,578	B1	12/2003	Evans	7,112,148	B2	9/2006	Deshmukh
6,669,580	B1	12/2003	Cackett et al.	7,118,493	B2	10/2006	Galloway
6,676,536	B1	1/2004	Jacobson	7,121,957	B2	10/2006	Hocknell et al.
6,679,786	B2	1/2004	McCabe	7,125,344	B2	10/2006	Hocknell et al.
D486,542	S	2/2004	Burrows	7,128,661	B2	10/2006	Soracco et al.
6,716,111	B2	4/2004	Liberatore	7,134,971	B2	11/2006	Franklin et al.
6,716,114	B2	4/2004	Nishio	7,137,906	B2	11/2006	Tsunoda et al.
6,719,510	B2	4/2004	Cobzaru	7,137,907	B2	11/2006	Gibbs et al.
6,719,641	B2	4/2004	Dabbs et al.	7,140,974	B2	11/2006	Chao et al.
6,719,645	B2	4/2004	Kouno	7,144,334	B2	12/2006	Ehlers et al.
6,723,002	B1	4/2004	Barlow	7,147,573	B2	12/2006	DiMarco
6,739,982	B2	5/2004	Murphy et al.	7,153,220	B2	12/2006	Lo
6,739,983	B2	5/2004	Helmstetter et al.	7,156,750	B2	1/2007	Nishitani et al.
6,743,118	B1	6/2004	Soracco	7,163,468	B2	1/2007	Gibbs et al.
6,749,523	B1	6/2004	Forzano	7,163,470	B2	1/2007	Galloway et al.
6,757,572	B1	6/2004	Forest	7,166,038	B2	1/2007	Williams et al.
6,758,763	B2	7/2004	Murphy et al.	7,166,040	B2	1/2007	Hoffman et al.
6,766,726	B1	7/2004	Schwarzkopf	7,166,041	B2	1/2007	Evans
6,773,359	B1	8/2004	Lee	7,169,058	B1	1/2007	Fagan
6,773,360	B2	8/2004	Willett et al.	7,169,060	B2	1/2007	Stevens et al.
6,773,361	B1	8/2004	Lee	D536,402	S	2/2007	Kawami
6,776,726	B2	8/2004	Sano	7,179,034	B2	2/2007	Ladouceur
6,783,465	B2	8/2004	Matsunaga	7,186,190	B1	3/2007	Beach et al.
6,800,038	B2	10/2004	Willett et al.	7,189,169	B2	3/2007	Billings
6,800,040	B2	10/2004	Galloway et al.	7,198,575	B2	4/2007	Beach et al.
6,805,643	B1	10/2004	Lin	7,201,669	B2	4/2007	Stites et al.
6,808,460	B2	10/2004	Namiki	D543,600	S	5/2007	Oldknow
6,811,496	B2	11/2004	Wahl et al.	7,211,005	B2	5/2007	Lindsay et
6,821,214	B2	11/2004	Rice	7,211,006	B2*	5/2007	Chang 473/329
6,824,475	B2	11/2004	Burnett et al.	7,214,143	B2	5/2007	Deshmukh
6,835,145	B2	12/2004	Tsurumaki	7,223,180	B2	5/2007	Willett et al.
D501,036	S	1/2005	Burrows	D544,939	S	6/2007	Radcliffe et al.
D501,523	S	2/2005	Dogan et al.	7,226,366	B2	6/2007	Galloway
D501,903	S	2/2005	Tanaka	7,250,007	B2	7/2007	Lu
6,855,068	B2	2/2005	Antonious	7,252,600	B2	8/2007	Murphy et al.
6,860,818	B2	3/2005	Mahaffey et al.	7,255,654	B2	8/2007	Murphy et al.
6,860,823	B2	3/2005	Lee	7,258,626	B2	8/2007	Gibbs et al.
6,860,824	B2	3/2005	Evans	7,258,631	B2	8/2007	Galloway et al.
D504,478	S	4/2005	Burrows	7,267,620	B2	9/2007	Chao et al.
6,875,124	B2	4/2005	GILBERT et al.	7,273,423	B2	9/2007	Imamoto
6,875,129	B2	4/2005	Erickson et al.	D552,701	S	10/2007	Ruggiero et al.
6,875,130	B2	4/2005	Nishio	7,278,927	B2	10/2007	Gibbs et al.
6,881,158	B2	4/2005	Yang et al.	7,281,985	B2	10/2007	Galloway
6,881,159	B2	4/2005	Galloway et al.	D554,720	S	11/2007	Barez et al.
				7,291,074	B2	11/2007	Kouno et al.
				7,294,064	B2*	11/2007	Tsurumaki et al. 473/329
				7,294,065	B2	11/2007	Liang et al.
				7,297,072	B2	11/2007	Meyer et al.

(56)

References Cited

U.S. PATENT DOCUMENTS

7,303,488	B2	12/2007	Kakiuchi et al.	2002/0160854	A1	10/2002	Beach et al.
7,306,527	B2	12/2007	Williams et al.	2002/0183130	A1	12/2002	Pacinella
7,314,418	B2	1/2008	Galloway et al.	2002/0183134	A1	12/2002	Allen et al.
7,318,782	B2	1/2008	Imamoto et al.	2003/0013545	A1	1/2003	Vincent et al.
7,320,646	B2	1/2008	Galloway et al.	2003/0032500	A1	2/2003	Nakahara et al.
D561,286	S	2/2008	Morales et al.	2003/0130059	A1	7/2003	Billings
7,344,452	B2	3/2008	Imamoto et al.	2003/0176238	A1	9/2003	Galloway et al.
7,347,795	B2	3/2008	Yamagishi et al.	2003/0220154	A1	11/2003	Anelli
7,354,355	B2	4/2008	Tavares et al.	2004/0087388	A1	5/2004	Beach et al.
7,377,860	B2	5/2008	Breier et al.	2004/0121852	A1	6/2004	Tsurumaki
7,387,577	B2	6/2008	Murphy et al.	2004/0157678	A1	8/2004	Kohno
7,390,266	B2	6/2008	Gwon	2004/0176180	A1	9/2004	Yamaguchi et al.
7,396,293	B2	7/2008	Soracco	2004/0176183	A1	9/2004	Tsurumaki
7,396,296	B2	7/2008	Evans et al.	2004/0192463	A1	9/2004	Tsurumaki et al.
7,402,112	B2	7/2008	Galloway et al.	2004/0235584	A1	11/2004	Chao et al.
7,407,447	B2	8/2008	Beach et al.	2004/0242343	A1	12/2004	Chao et al.
7,407,448	B2	8/2008	Stevens et al.	2005/0003905	A1	1/2005	Kim et al.
7,413,520	B1	8/2008	Hocknell et al.	2005/0026716	A1	2/2005	Wahl et al.
D577,090	S	9/2008	Pergande et al.	2005/0049081	A1	3/2005	Boone
7,419,441	B2	9/2008	Hoffman et al.	2005/0101404	A1	5/2005	Long et al.
D579,507	S	10/2008	Llewellyn et al.	2005/0119070	A1	6/2005	Kumamoto
7,431,667	B2	10/2008	Vincent et al.	2005/0137024	A1	6/2005	Stites et al.
7,438,647	B1	10/2008	Hocknell	2005/0181884	A1	8/2005	Beach et al.
7,438,649	B2	10/2008	Ezaki et al.	2005/0239575	A1	10/2005	Chao et al.
7,448,963	B2	11/2008	Beach et al.	2005/0239576	A1	10/2005	Stites et al.
7,455,598	B2	11/2008	Williams et al.	2006/0009305	A1	1/2006	Lindsay
7,470,201	B2	12/2008	Nakahara et al.	2006/0035722	A1	2/2006	Beach et al.
D584,784	S	1/2009	Barez et al.	2006/0052177	A1	3/2006	Nakahara et al.
7,476,161	B2	1/2009	Williams et al.	2006/0058112	A1	3/2006	Haralason et al.
7,491,134	B2	2/2009	Murphy et al.	2006/0073910	A1	4/2006	Imamoto et al.
D588,223	S	3/2009	Kuan	2006/0084525	A1	4/2006	Imamoto et al.
7,497,787	B2	3/2009	Murphy et al.	2006/0094535	A1	5/2006	Cameron
7,500,924	B2	3/2009	Yokota	2006/0122004	A1	6/2006	Chen et al.
7,520,820	B2	4/2009	Dimarco	2006/0154747	A1	7/2006	Beach
D592,723	S	5/2009	Chau et al.	2006/0172821	A1	8/2006	Evans
7,530,901	B2	5/2009	Imamoto et al.	2006/0240908	A1	10/2006	Adams et al.
7,530,904	B2	5/2009	Beach et al.	2006/0281581	A1	12/2006	Yamamoto
7,540,811	B2	6/2009	Beach et al.	2007/0026961	A1	2/2007	Hou
7,549,935	B2	6/2009	Foster et al.	2007/0049416	A1	3/2007	Shear
7,563,175	B2	7/2009	Nishitani et al.	2007/0049417	A1	3/2007	Shear
7,568,985	B2	8/2009	Beach et al.	2007/0082751	A1	4/2007	Lo et al.
7,572,193	B2	8/2009	Yokota	2007/0105646	A1	5/2007	Beach et al.
7,578,751	B2	8/2009	Williams et al.	2007/0105647	A1	5/2007	Beach et al.
7,578,753	B2	8/2009	Beach et al.	2007/0105648	A1	5/2007	Beach et al.
D600,767	S	9/2009	Horacek et al.	2007/0105649	A1	5/2007	Beach et al.
7,582,024	B2*	9/2009	Shear	2007/0105650	A1	5/2007	Beach et al.
7,591,737	B2	9/2009	Gibbs et al.	2007/0105651	A1	5/2007	Beach et al.
7,591,738	B2	9/2009	Beach et al.	2007/0105652	A1	5/2007	Beach et al.
D604,784	S	11/2009	Horacek et al.	2007/0105653	A1	5/2007	Beach et al.
7,621,823	B2	11/2009	Beach et al.	2007/0105654	A1	5/2007	Beach et al.
7,628,707	B2	12/2009	Beach et al.	2007/0105655	A1	5/2007	Beach et al.
7,632,196	B2*	12/2009	Reed et al.	2007/0117648	A1	5/2007	Yokota
D612,440	S	3/2010	Oldknow	2007/0117652	A1	5/2007	Beach et al.
7,682,264	B2	3/2010	Hsu et al.	2007/0275792	A1	11/2007	Horacek et al.
7,717,807	B2	5/2010	Evans et al.	2008/0146370	A1	6/2008	Beach et al.
D616,952	S	6/2010	Oldknow	2008/0161127	A1	7/2008	Yamamoto
7,749,096	B2	7/2010	Gibbs et al.	2008/0254911	A1	10/2008	Beach et al.
7,749,097	B2	7/2010	Foster et al.	2008/0261717	A1	10/2008	Hoffman et al.
7,815,520	B2	10/2010	Frame et al.	2008/0280698	A1	11/2008	Hoffman et al.
7,857,711	B2*	12/2010	Shear	2009/0088269	A1	4/2009	Beach et al.
D631,119	S	1/2011	Albertsen et al.	2009/0088271	A1	4/2009	Beach et al.
7,867,105	B2	1/2011	Moon	2009/0137338	A1	5/2009	Kajita
7,988,565	B2	8/2011	Abe	2009/0170632	A1	7/2009	Beach et al.
8,083,609	B2*	12/2011	Burnett et al.	2009/0181789	A1	7/2009	Reed et al.
8,088,021	B2*	1/2012	Albertsen et al.	2009/0286622	A1	11/2009	Yokota
8,162,775	B2	4/2012	Tavares et al.	2010/0029404	A1	2/2010	Shear
8,216,087	B2	7/2012	Breier et al.	2010/0048316	A1	2/2010	Honea et al.
2001/0049310	A1	12/2001	Cheng et al.	2010/0048321	A1	2/2010	Beach et al.
2002/0022535	A1	2/2002	Takeda	2010/0113176	A1	5/2010	Boyd et al.
2002/0032075	A1	3/2002	Vatsvog	2010/0178997	A1	7/2010	Gibbs et al.
2002/0055396	A1	5/2002	Nishimoto et al.	2011/0021284	A1	1/2011	Stites et al.
2002/0072434	A1	6/2002	Yabu	2011/0151989	A1	6/2011	Golden et al.
2002/0115501	A1	8/2002	Chen	2011/0151997	A1	6/2011	Shear
2002/0123394	A1	9/2002	Tsurumaki	2011/0218053	A1	9/2011	Tang et al.
2002/0137576	A1	9/2002	Dammen	2011/0244979	A1	10/2011	Snyder
				2011/0281663	A1	11/2011	Stites et al.
				2011/0281664	A1	11/2011	Boyd et al.
				2011/0294599	A1	12/2011	Albertsen et al.
				2012/0034997	A1	2/2012	Swartz

(56)

References Cited

U.S. PATENT DOCUMENTS

2012/0083362 A1 4/2012 Albertsen et al.
 2012/0083363 A1 4/2012 Albertsen et al.
 2012/0135821 A1 5/2012 Boyd et al.
 2012/0142447 A1 6/2012 Boyd et al.
 2012/0178548 A1 7/2012 Tavares et al.
 2012/0196701 A1 8/2012 Stites et al.
 2012/0196703 A1 8/2012 Sander

FOREIGN PATENT DOCUMENTS

DE 9012884 9/1990
 EP 0470488 2/1992
 EP 0617987 11/1997
 EP 1001175 5/2000
 GB 194823 12/1921
 JP 01091876 A2 4/1989
 JP 03049777 A 3/1991
 JP 03151988 A 6/1991
 JP 04180778 A 6/1992
 JP 4180778 A2 6/1992
 JP 05337220 A 12/1993
 JP H05317465 12/1993
 JP H06126004 5/1994
 JP 06182004 A 7/1994
 JP 06190088 7/1994
 JP H06238022 8/1994
 JP 06285186 A 10/1994
 JP H06304271 11/1994
 JP 08117365 A 5/1996
 JP H09028844 2/1997
 JP H09308717 12/1997
 JP H09327534 12/1997
 JP 10155943 A 6/1998
 JP H10234902 9/1998
 JP 10263118 A 10/1998
 JP H10277187 10/1998
 JP H11114102 4/1999
 JP 11-155982 6/1999
 JP 2000167089 A 6/2000
 JP 2000288131 A 10/2000
 JP 2000300701 A 10/2000
 JP 2000342721 A 12/2000
 JP 2000014841 A 1/2001
 JP 2001054595 2/2001
 JP 2001170225 6/2001
 JP 2001204856 7/2001
 JP 2001231888 A 8/2001
 JP 2001346918 12/2001
 JP 2002003969 1/2002
 JP 2002017910 1/2002
 JP 2002052099 2/2002
 JP 2002052099 A * 2/2002 A63B 53/04
 JP 2002136625 5/2002
 JP 2002248183 A 9/2002
 JP 2002248183 A 9/2002
 JP 2002253706 9/2002
 JP 2003024481 A 1/2003
 JP 2003038691 2/2003
 JP 2003052866 2/2003
 JP 2003093554 4/2003
 JP 2003093554 A * 4/2003 A63B 53/04
 JP 2003126311 5/2003
 JP 2003210621 7/2003
 JP 2003210627 A 7/2003
 JP 2003226952 8/2003
 JP 2003524487 8/2003
 JP 2004008409 1/2004
 JP 2004174224 6/2004
 JP 2004174224 A * 6/2004 A63B 53/04
 JP 2004183058 7/2004
 JP 2004222911 8/2004
 JP 2004267438 9/2004

JP 2004275700 10/2004
 JP 2004313762 11/2004
 JP 2004313762 A * 11/2004 A63B 53/04
 JP 2004-351054 12/2004
 JP 2004351173 12/2004
 JP 2004351173 A * 12/2004 A63B 53/04
 JP 2005028170 2/2005
 JP 2005073736 3/2005
 JP 2005111172 4/2005
 JP 2005137494 6/2005
 JP 2005137788 6/2005
 JP 2005193069 7/2005
 JP 2005193069 A * 7/2005 A63B 53/04
 JP 2005296582 10/2005
 JP 2005323978 11/2005
 JP 2006320493 11/2006
 JP 2007136069 6/2007
 JP 2007136069 A * 6/2007
 JP 2007275253 A 10/2007
 JP 4128970 7/2008
 JP 2009000281 A 1/2009
 JP 2010029590 A 2/2010
 JP 2010279847 A 12/2010
 JP 2011024999 A 2/2011
 WO WO8802642 4/1988
 WO WO0166199 9/2001
 WO WO02062501 8/2002
 WO WO03061773 7/2003
 WO WO2004043549 5/2004

OTHER PUBLICATIONS

Adams Golf Speedline F11 Ti 14.5 degree fairway wood (www.bombsquadgolf.com, posted Oct. 18, 2010).
 Callaway Golf, World's Straightest Driver: FT-i Driver downloaded from www.callawaygolf.com/ft%2Di/driver.aspx?lang=en on Apr. 5, 2007.
 Jackson, Jeff, The Modern Guide to Golf Clubmaking, Ohio: Dynacraft Golf Products, Inc., copyright 1994, p. 237.
 Nike Golf, Sasquatch 460, downloaded from www.nike.com/nikegolf/index.htm on Apr. 5, 2007.
 Nike Golf, Sasquatch Sumo Squared Driver, downloaded from www.nike.com/nikegolf/index.htm on Apr. 5, 2007.
 Office action from the U.S. Patent and Trademark office in the U.S. Appl. No. 12/781,727, dated Aug. 5, 2010.
 Taylor Made Golf Company, Inc. Press Release, Burner Fairway Wood, www.tmag.conn/media/pressreleases/2007/011807_burner_fairway_rescue.html, Jan. 26, 2007.
 Taylor Made Golf Company Inc., R7 460 Drivers, downloaded from www.taylormadegolf.com/product_detail.asp?pid=14section=overview on Apr. 5, 2007.
 Titleist 907D1, downloaded from www.tees2greens.com/forum/Uploads/Images/7ade3521-192b-4611-870b-395d.jpg on Feb. 1, 2007.
 Mike Stachura, "The Hot List", Golf Digest Magazine, Feb. 2004, pp. 82-86.
 Mike Stachura, "The Hot List", Golf Digest Magazine, Feb. 2005, pp. 120-130.
 Mike Stachura, "The Hot List", Golf Digest Magazine, Feb. 2005, pp. 131-143.
 Mike Stachura, "The Hot List", Golf Digest Magazine, Feb. 2006, pp. 122-132.
 Mike Stachura, "The Hot List", Golf Digest Magazine, Feb. 2006, pp. 133-143.
 Mike Stachura, "The Hot List", Golf Digest Magazine, Feb. 2007, pp. 130-151.
 "The Hot List", Golf Digest Magazine, Feb. 2008, pp. 114-139.
 Mike Stachura, Stina Sternberg, "Editor's Choices and Gold Medal Drivers", Golf Digest Magazine, Feb. 2010, pp. 95-109.
 The Hot List, Golf Digest Magazine, Feb. 2009, pp. 101-127.
 International Searching Authority (USPTO), International Search Report and Written Opinion for International Application No. PCT/US2011/0038150, mailed Sep. 16, 2011, 13 pages.

* cited by examiner

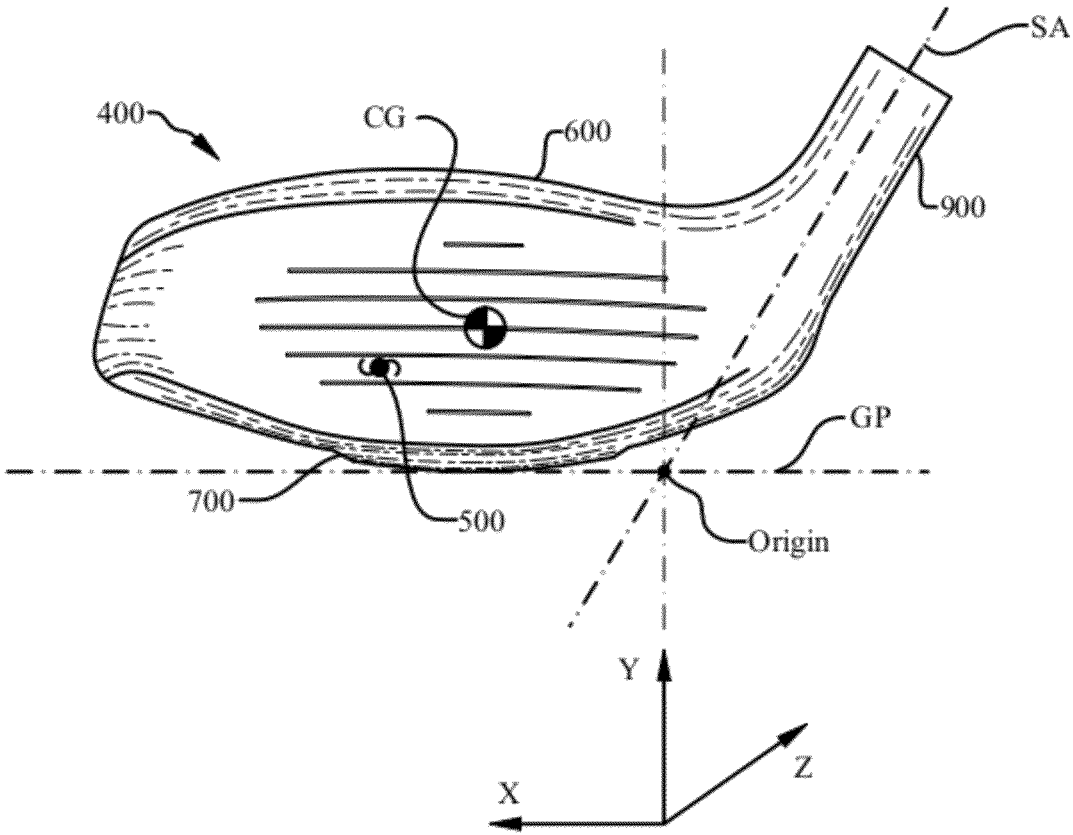

Fig. 1

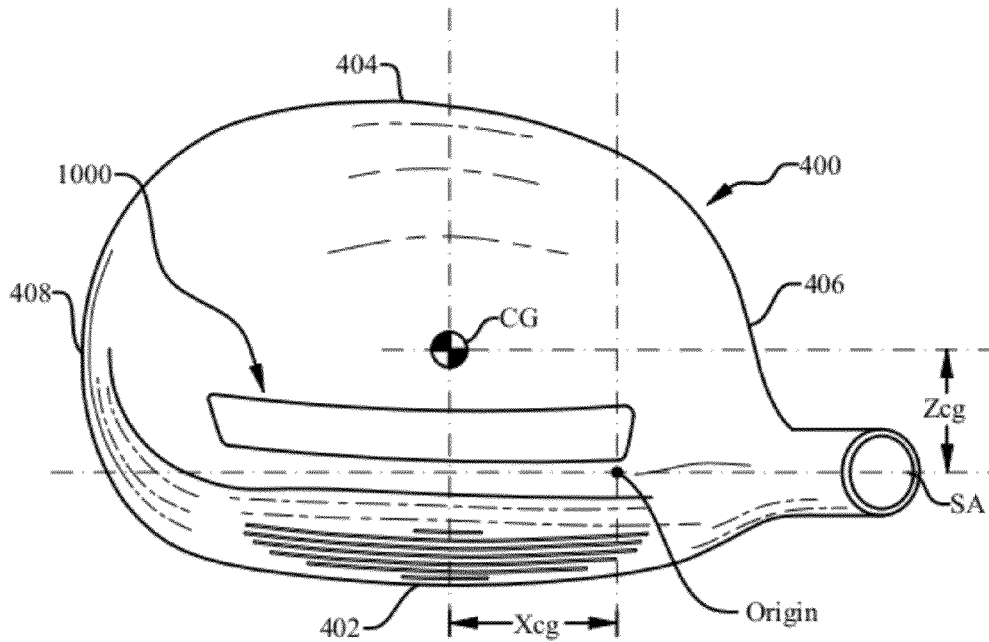

Fig. 2

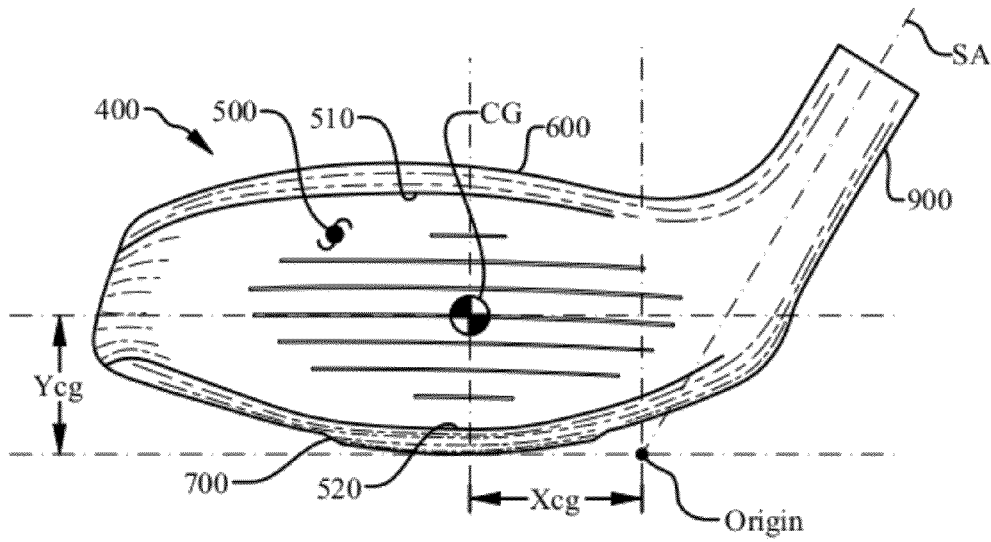

Fig. 3

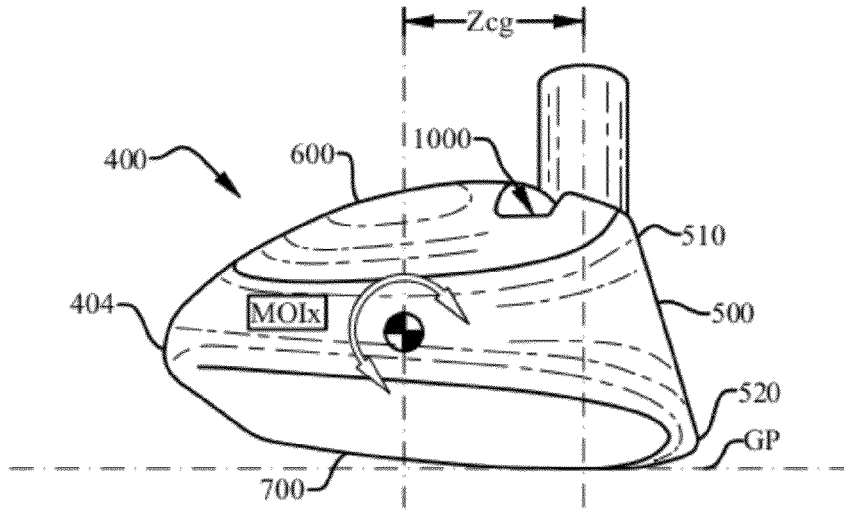

Fig. 4

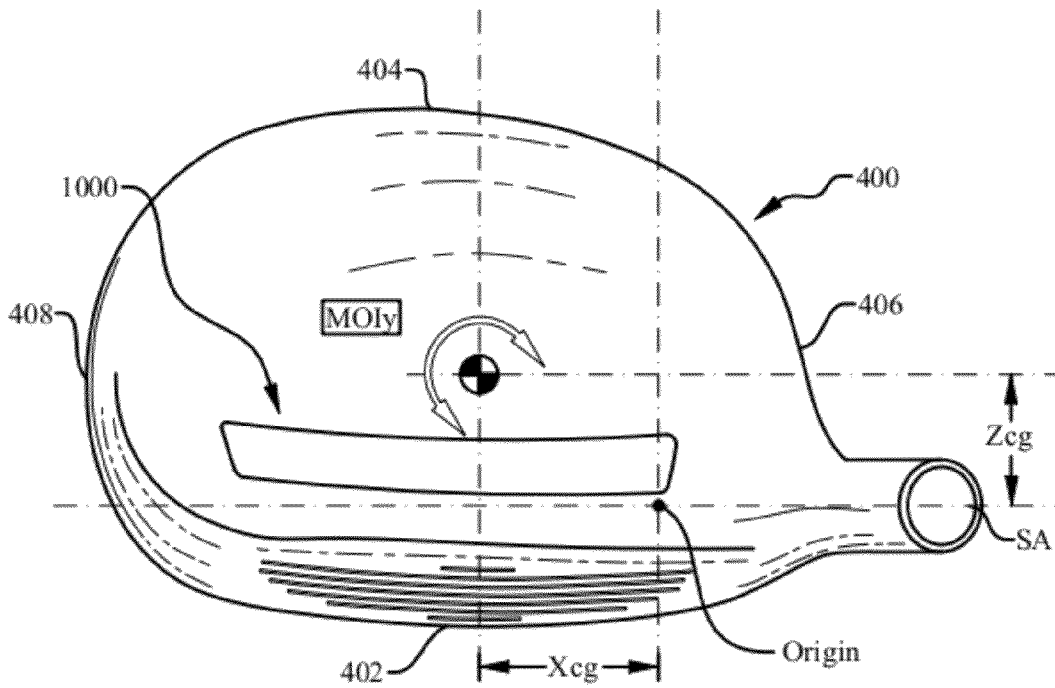

Fig. 5

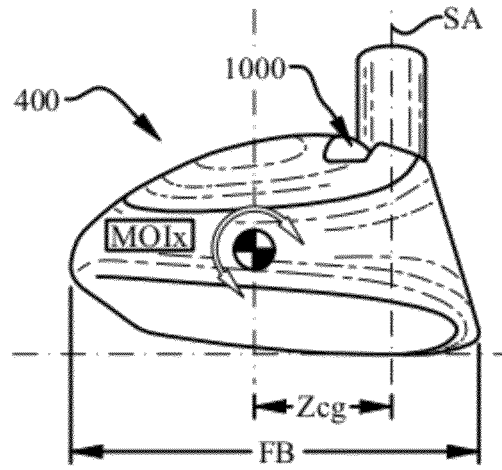

Fig. 6

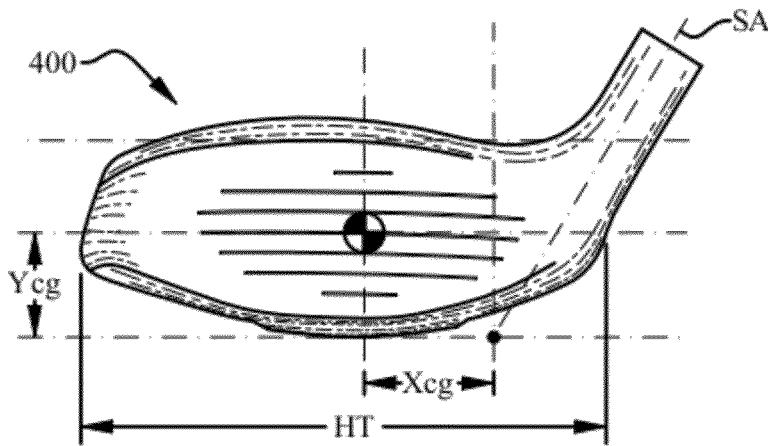

Fig. 7

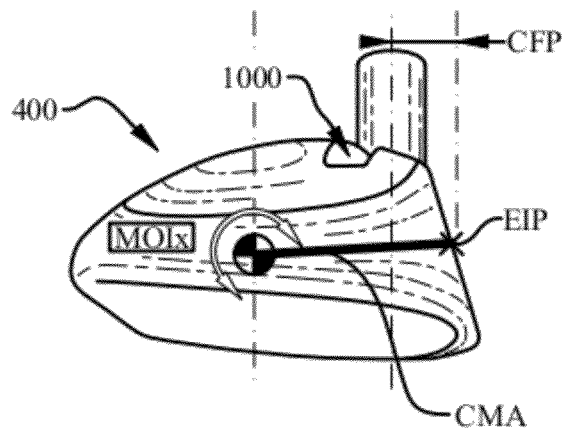

Fig. 8

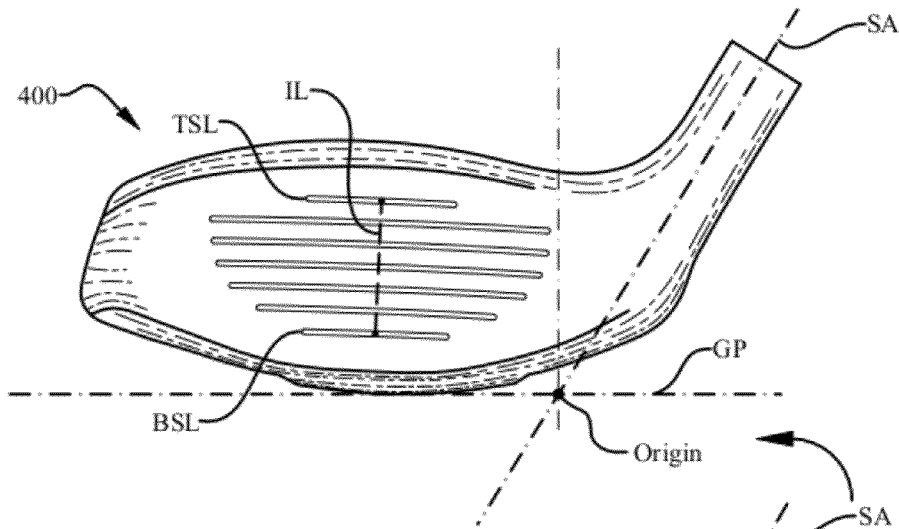

Fig. 9

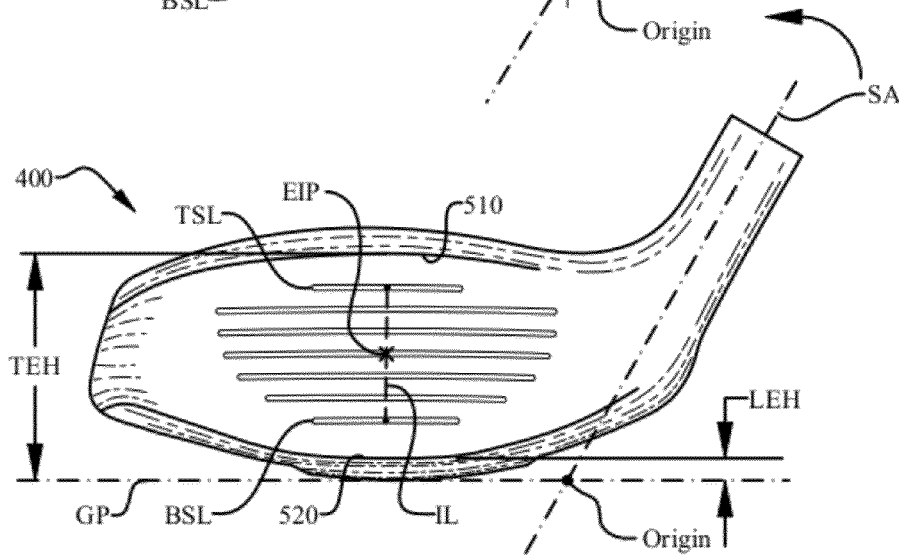

Fig. 10

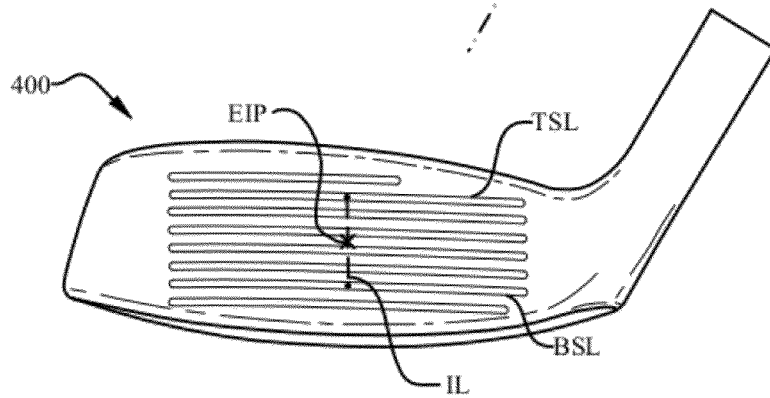

Fig. 11

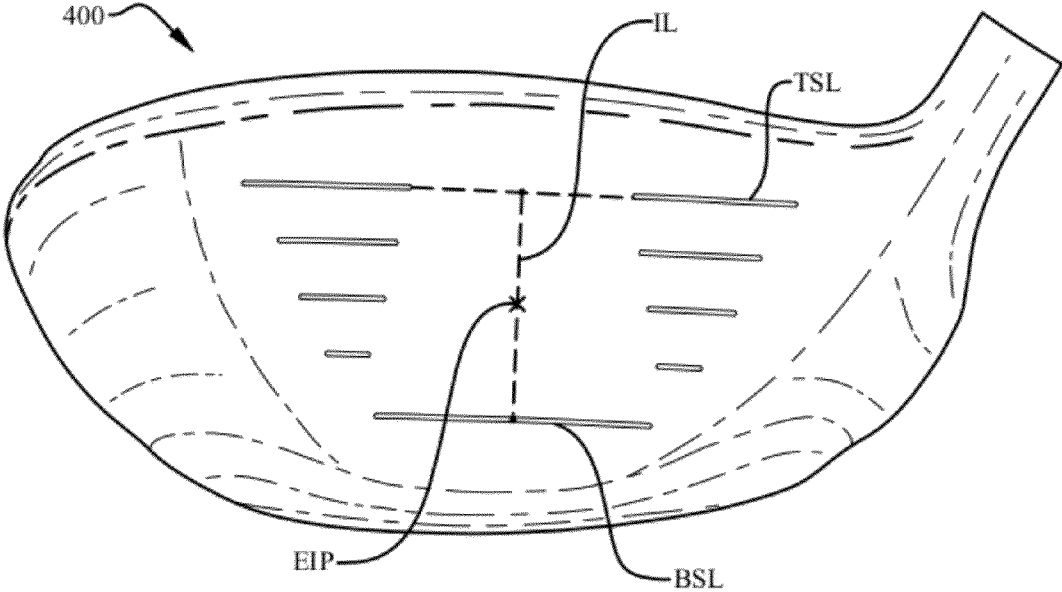

Fig. 12

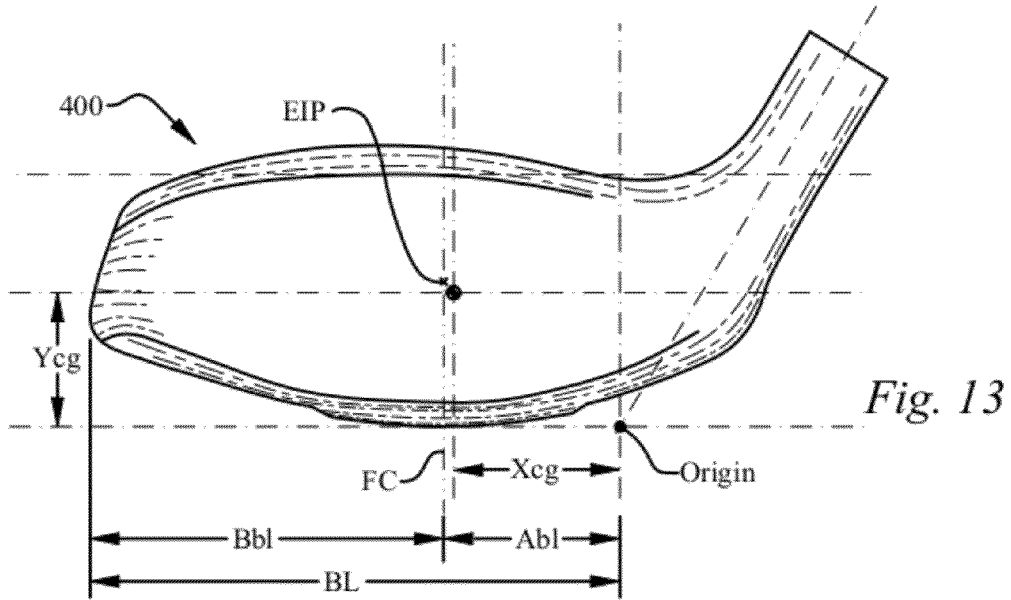

Fig. 13

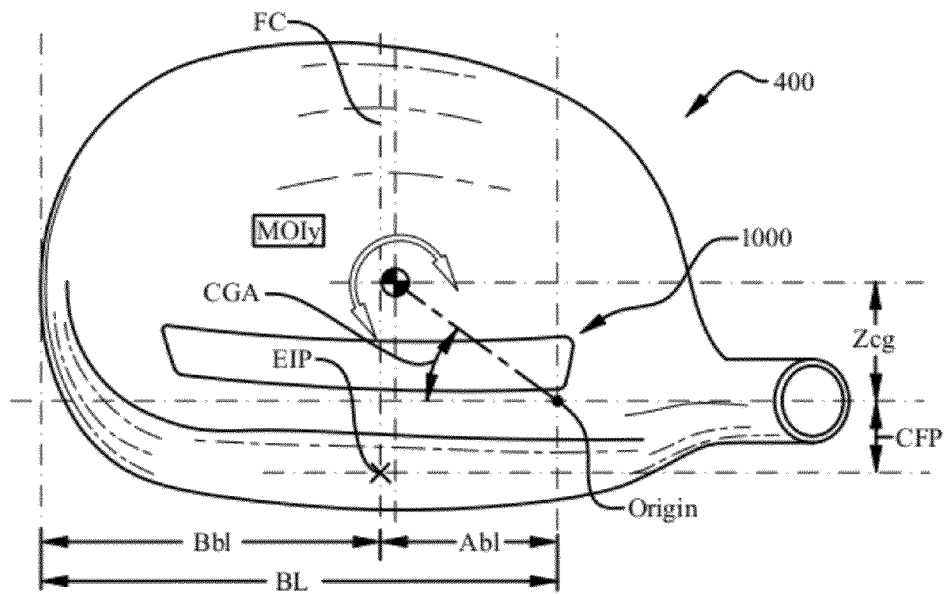

Fig. 14

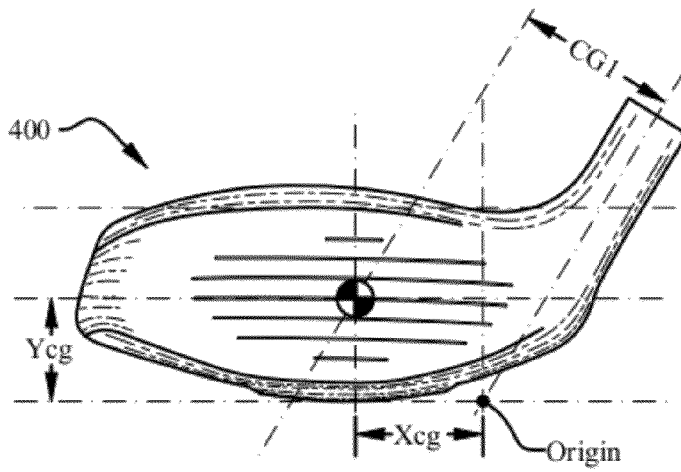

Fig. 15

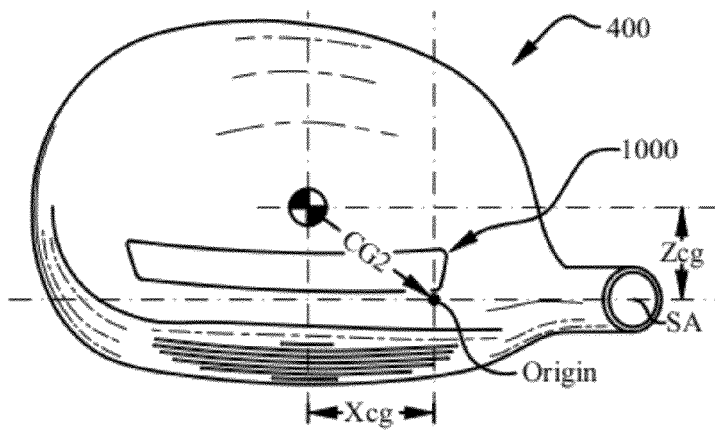

Fig. 16

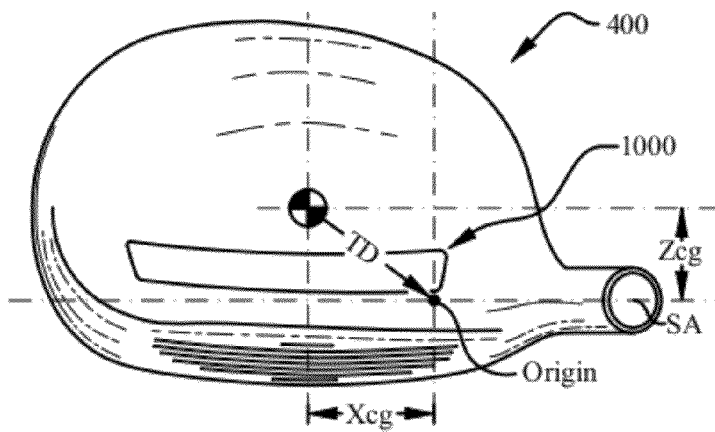

Fig. 17

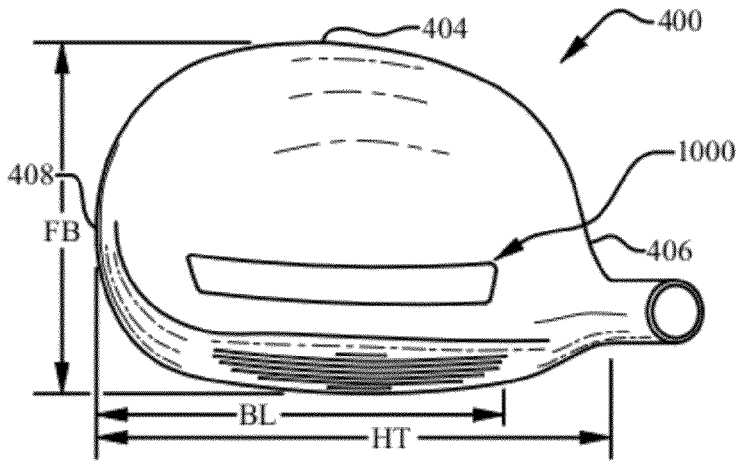

Fig. 18

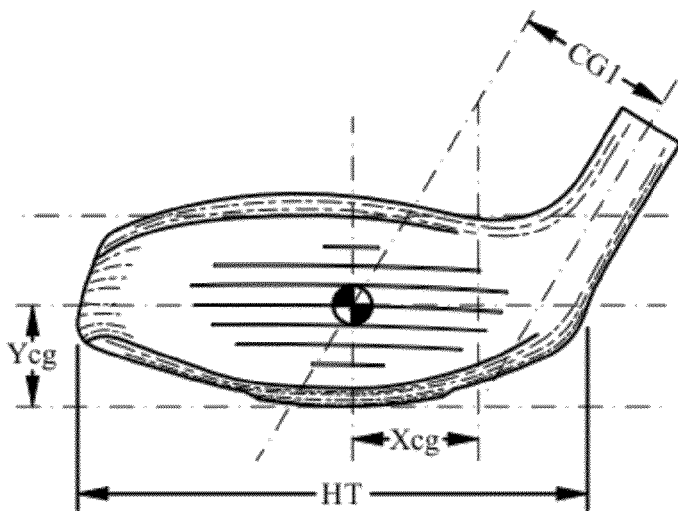

Fig. 19

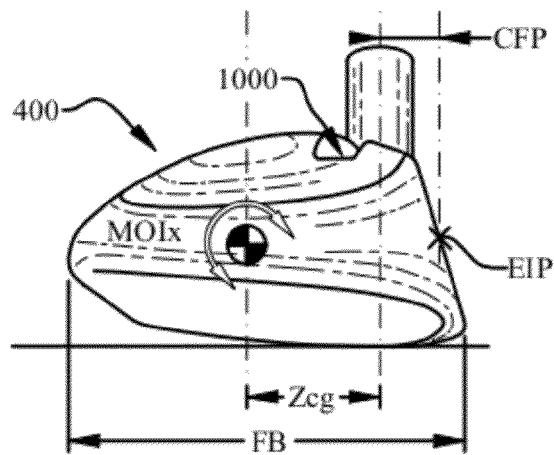

Fig. 20

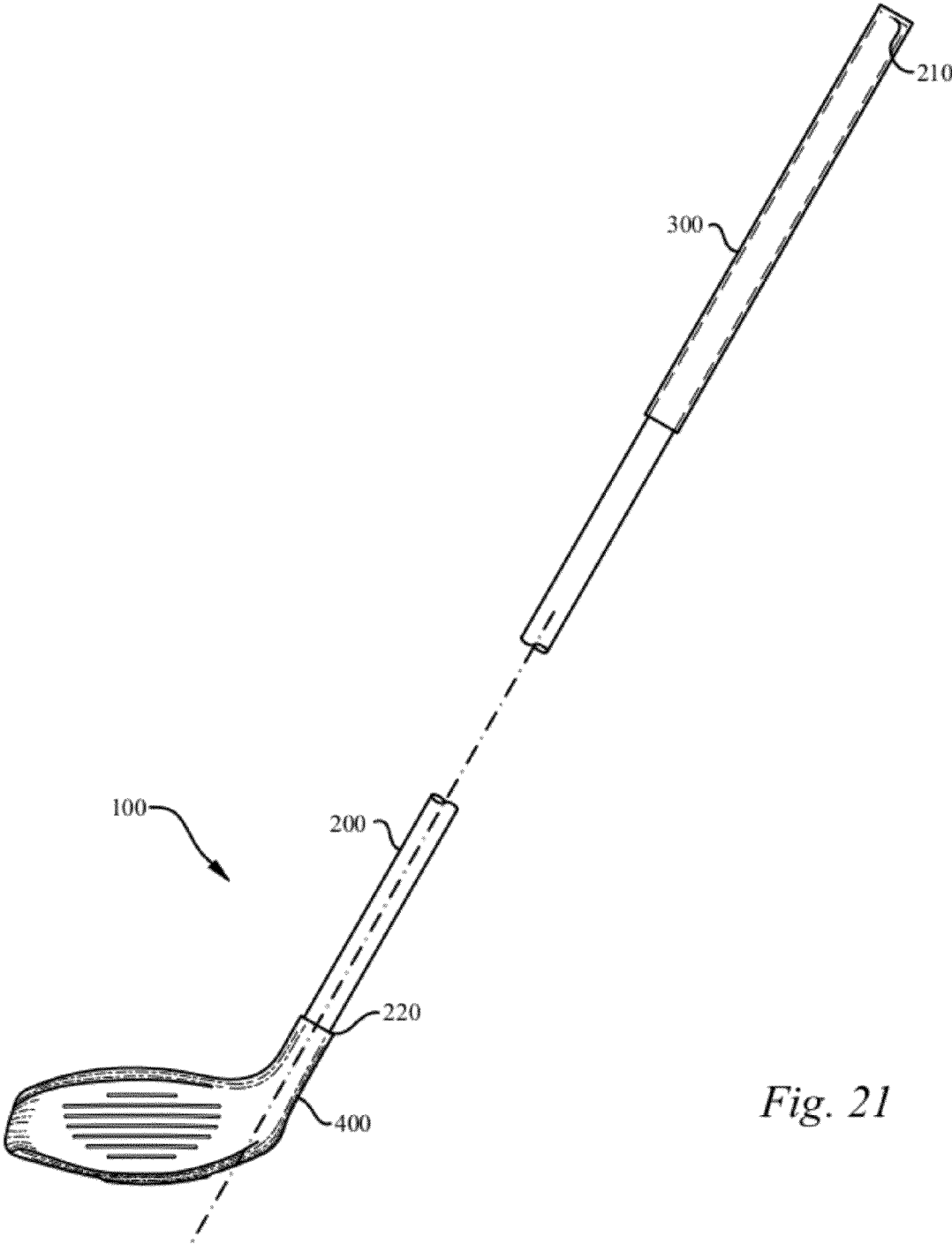

Fig. 21

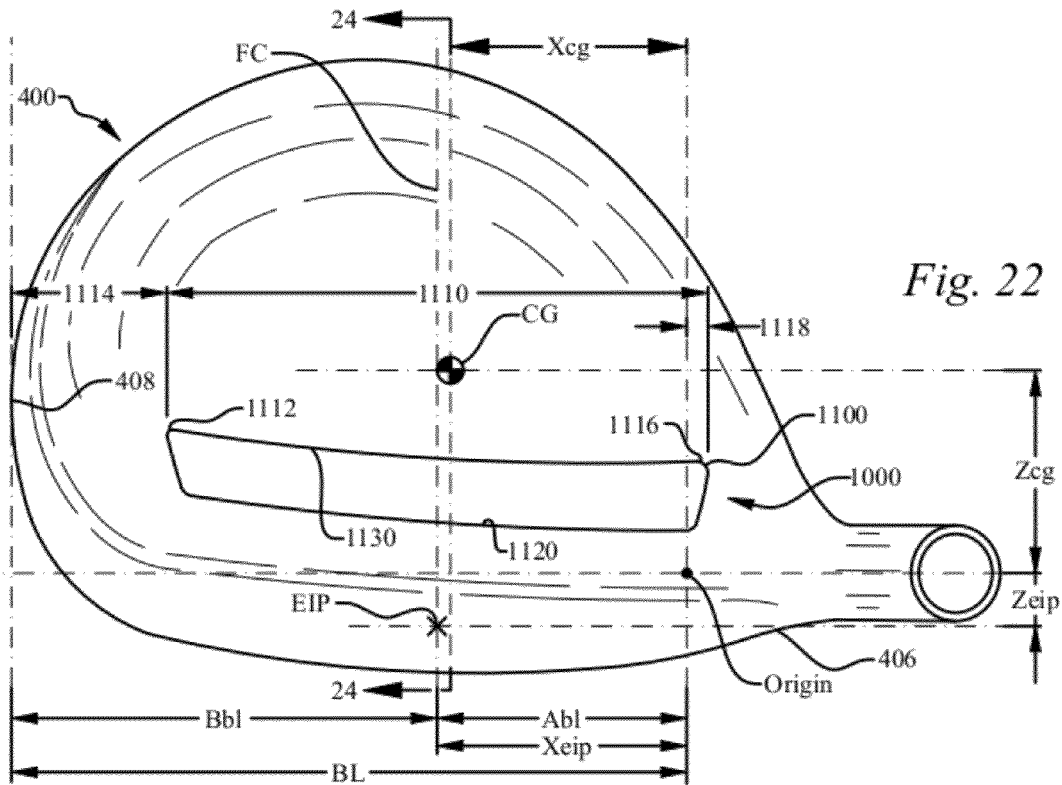

Fig. 22

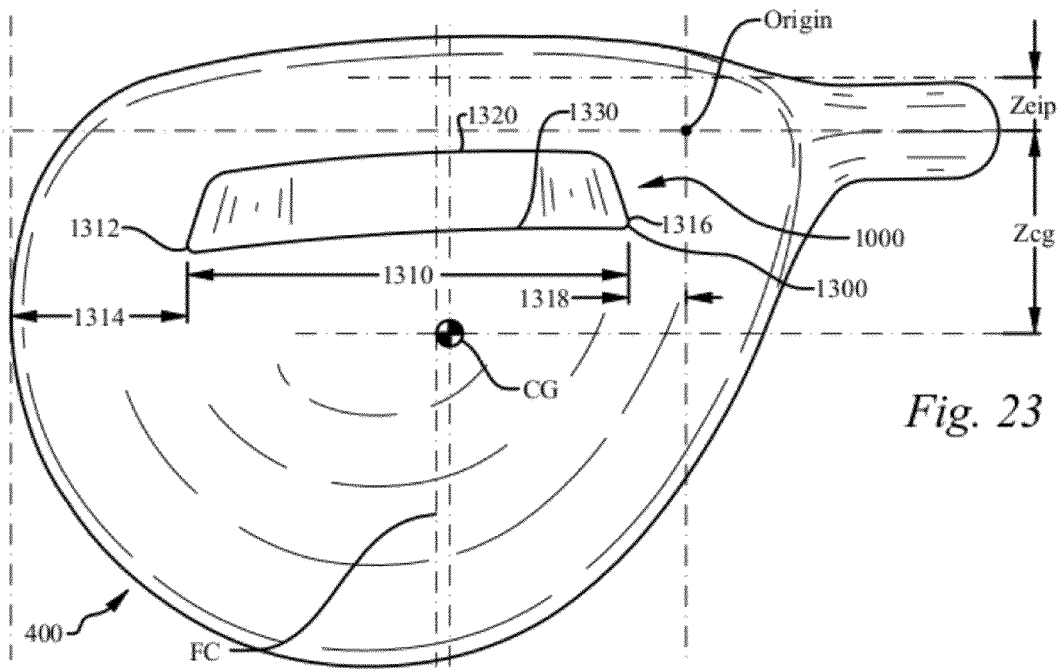

Fig. 23

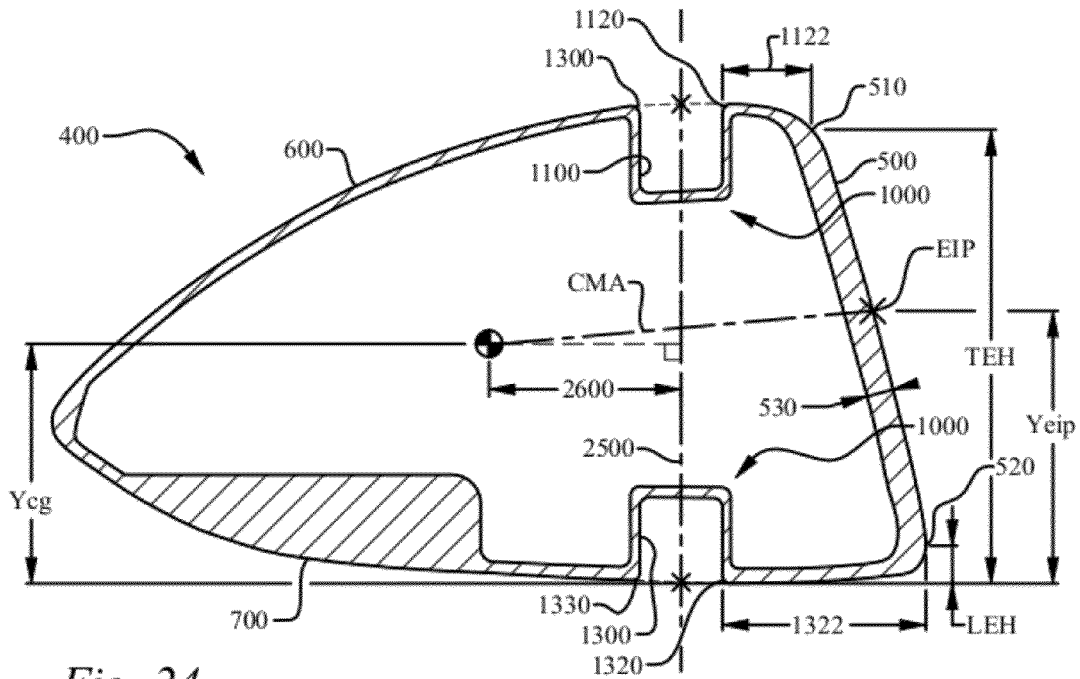

Fig. 24

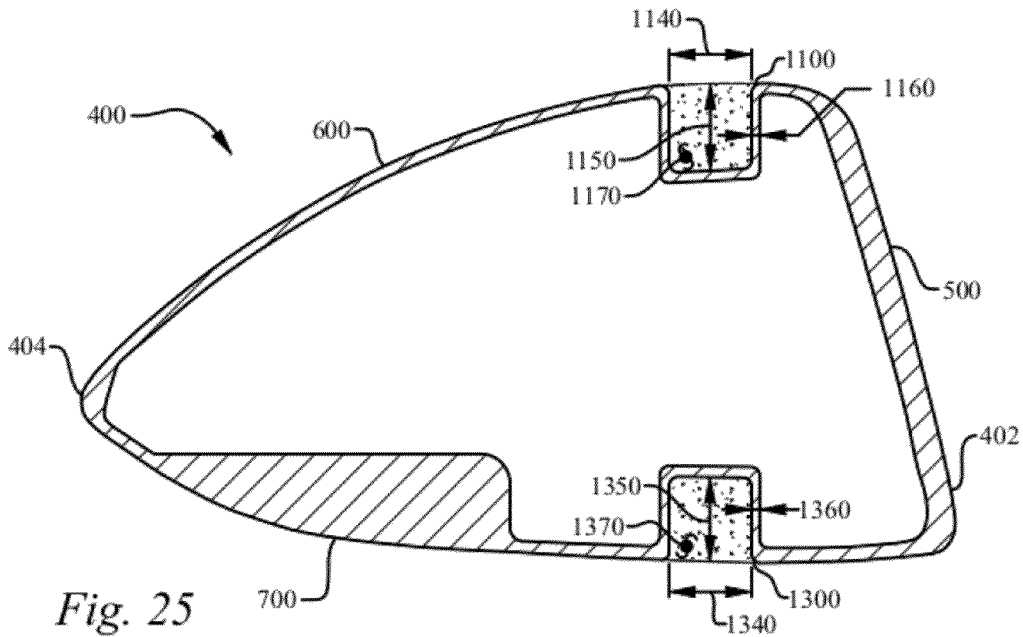

Fig. 25

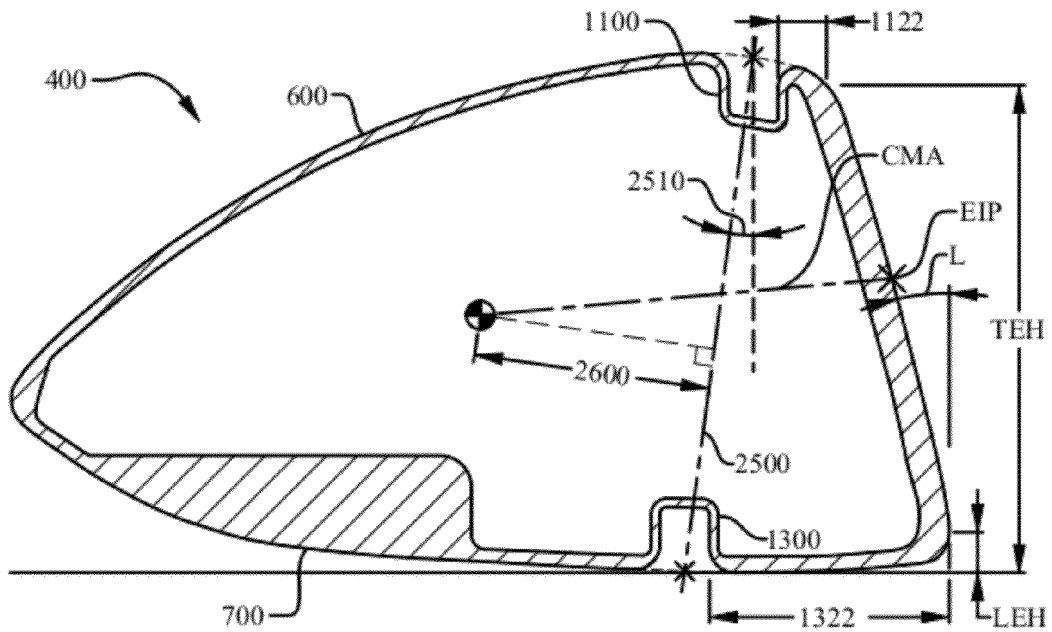

Fig. 26

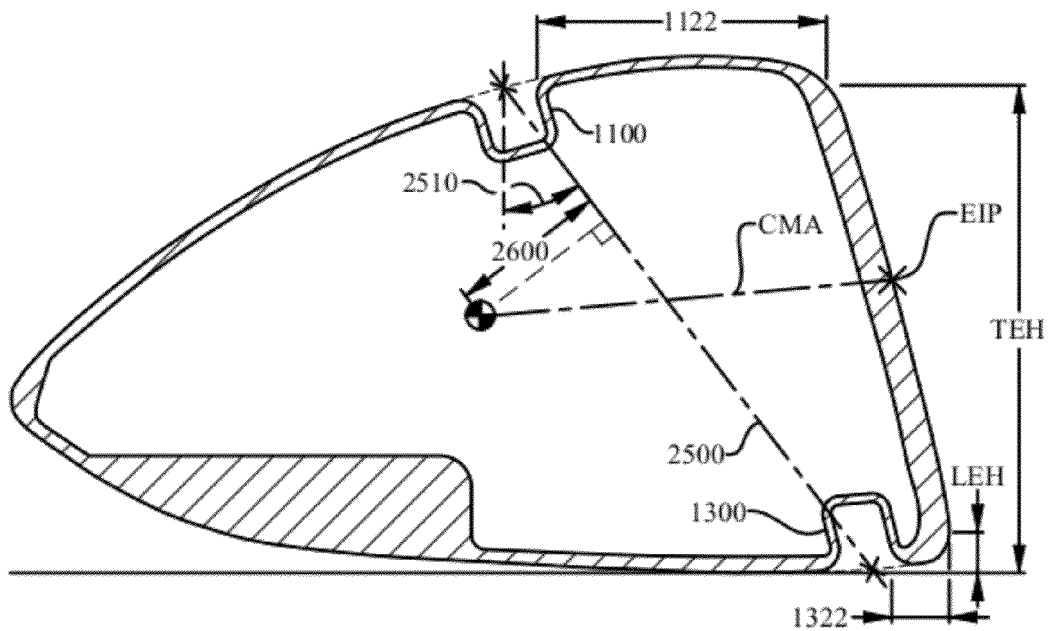

Fig. 27

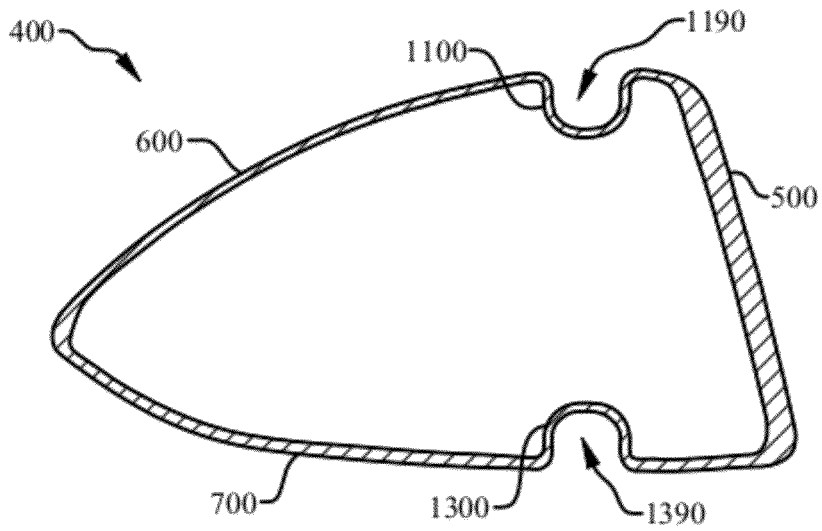

Fig. 28

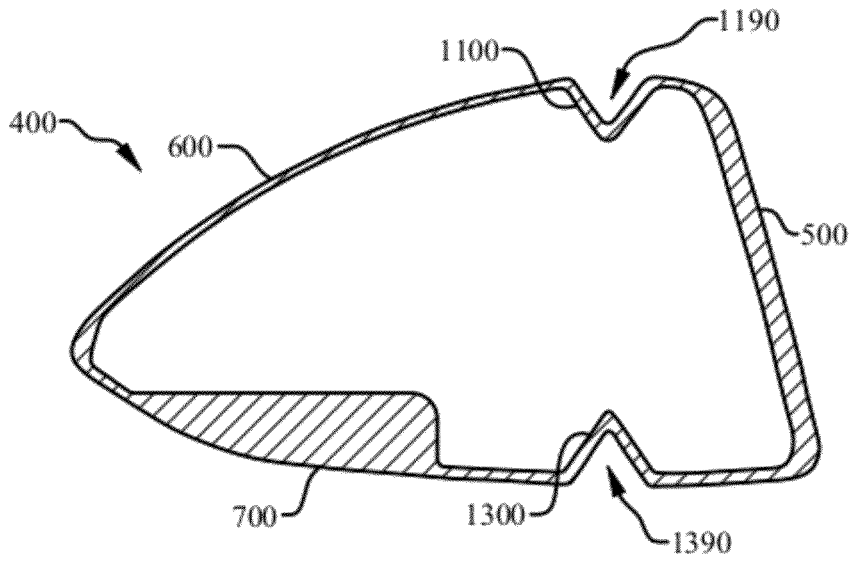

Fig. 29

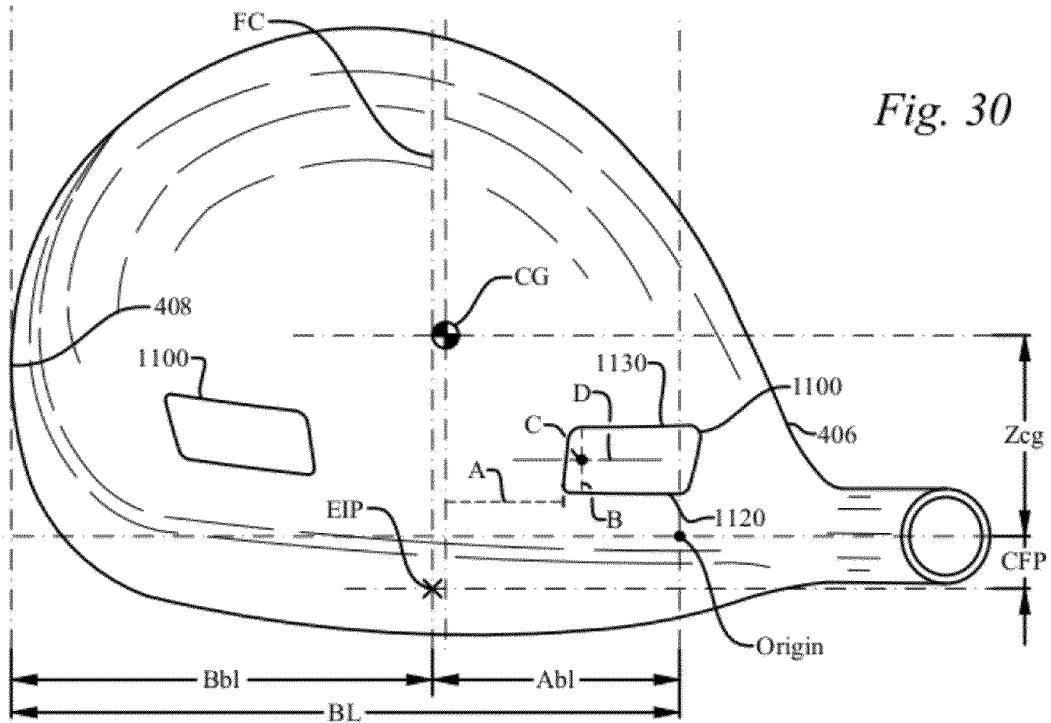

Fig. 30

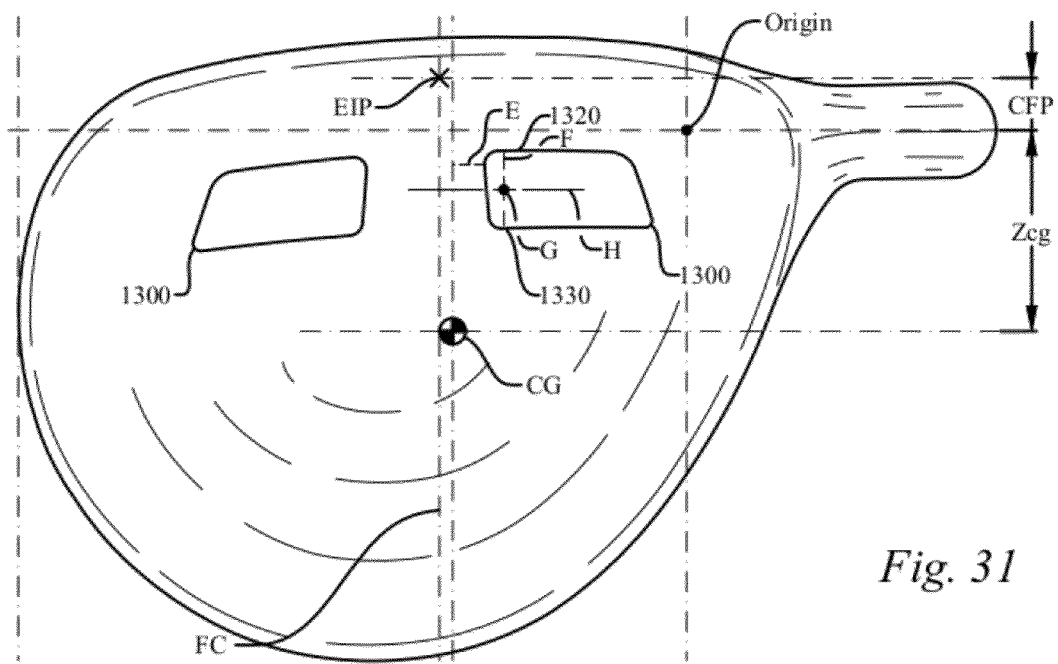

Fig. 31

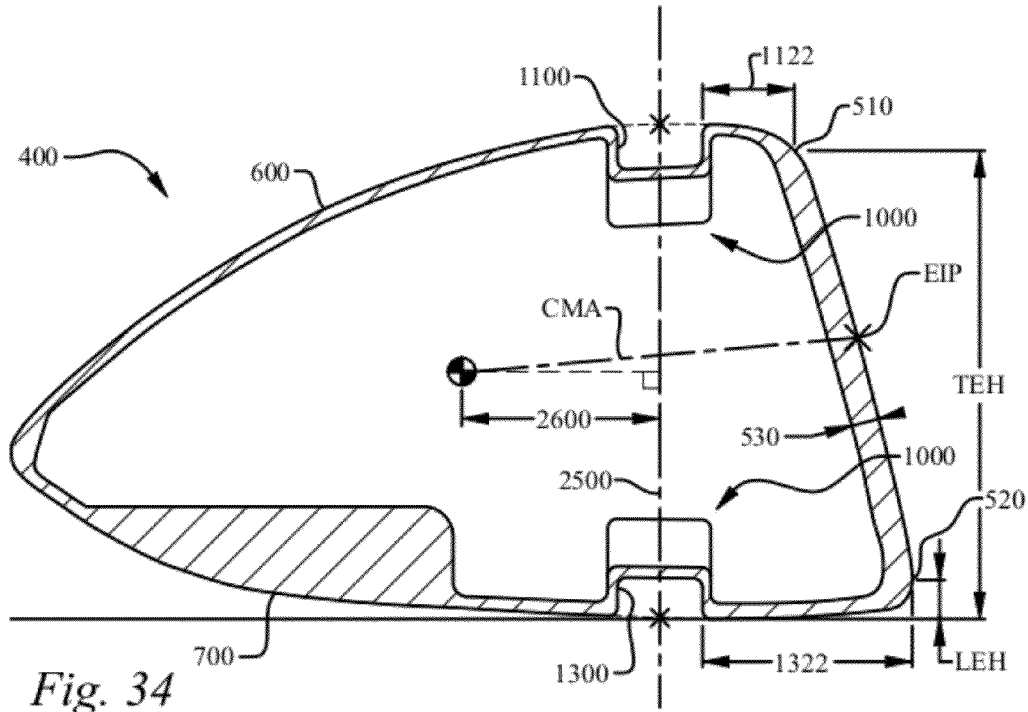

Fig. 34

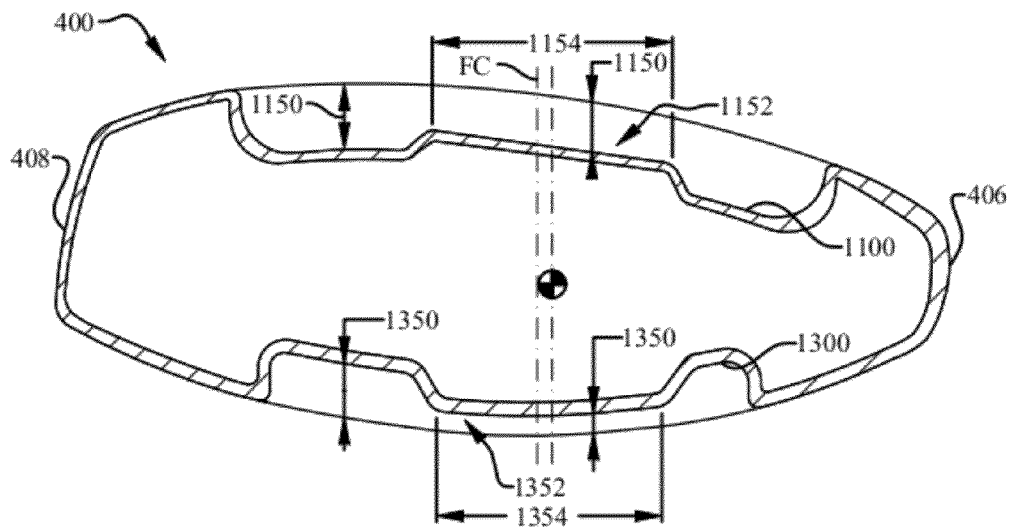

Fig. 35

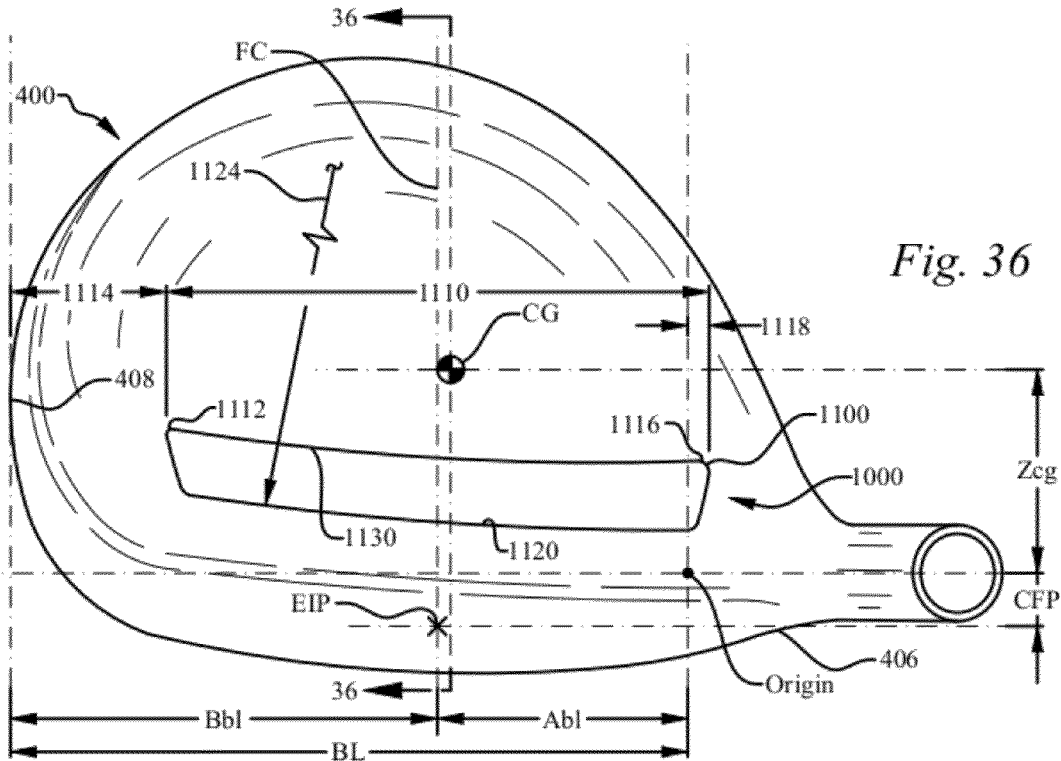

Fig. 36

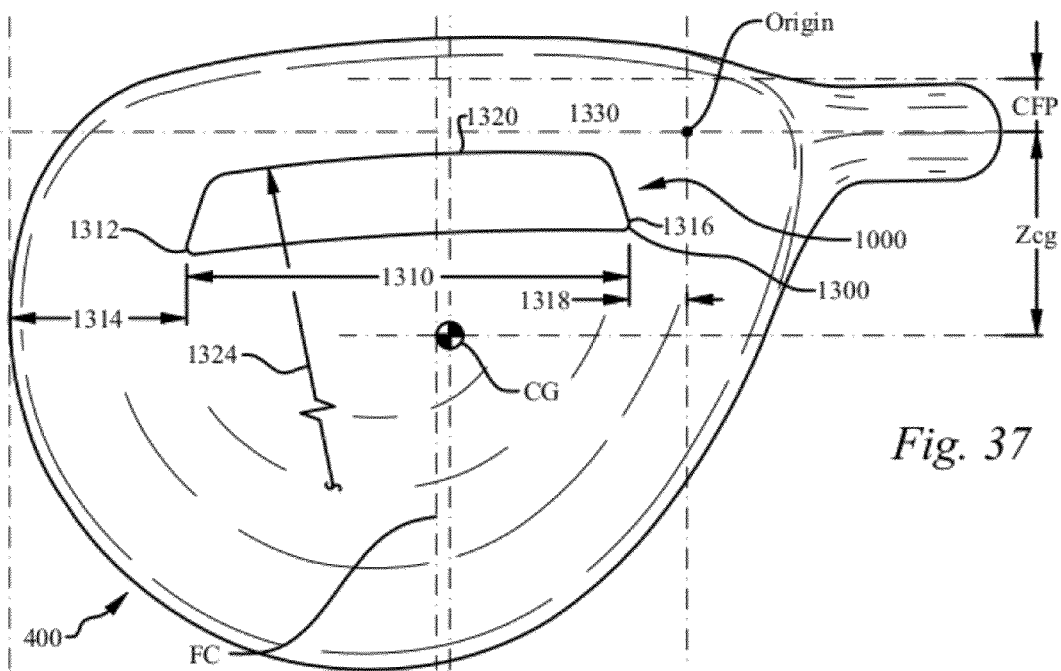
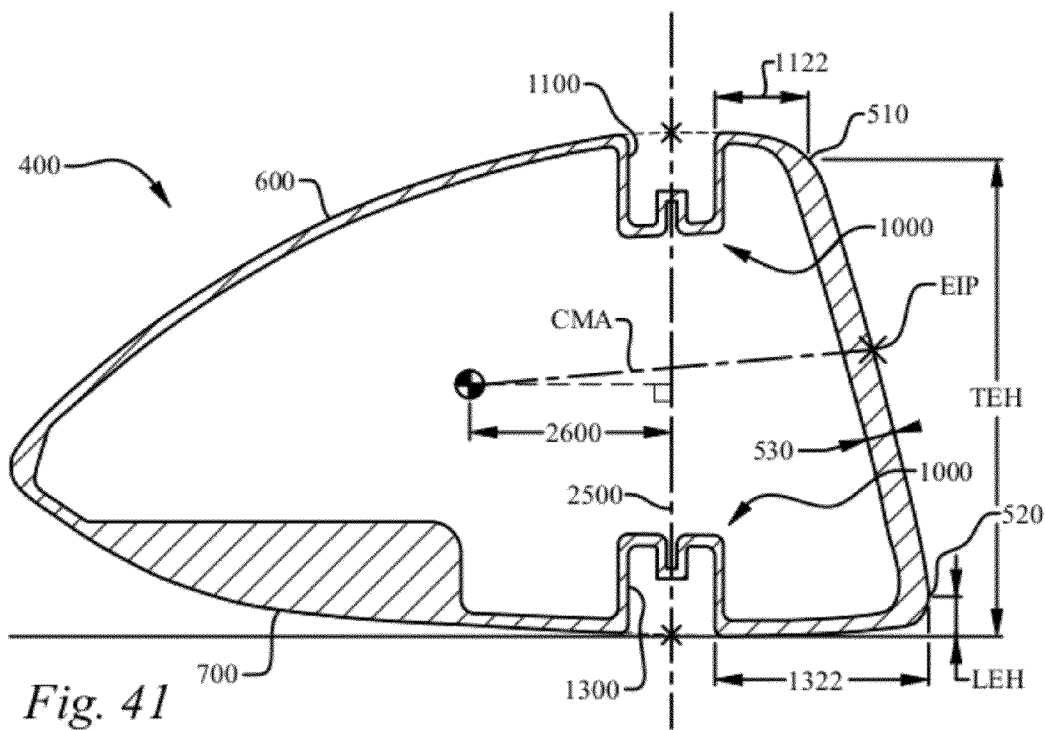
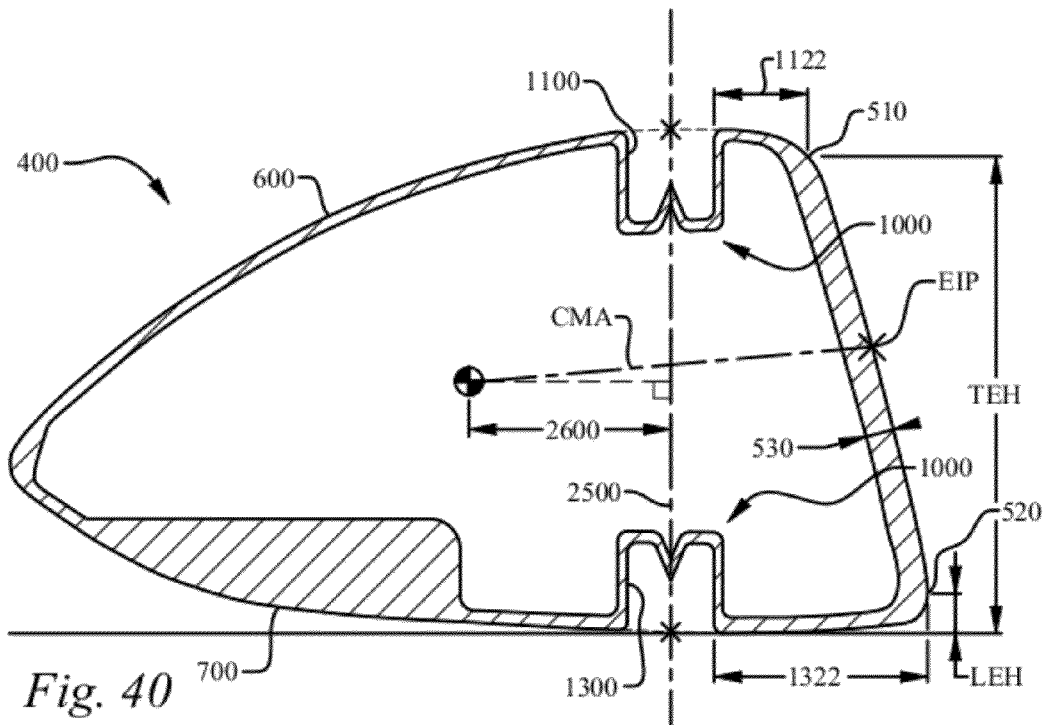

Fig. 37



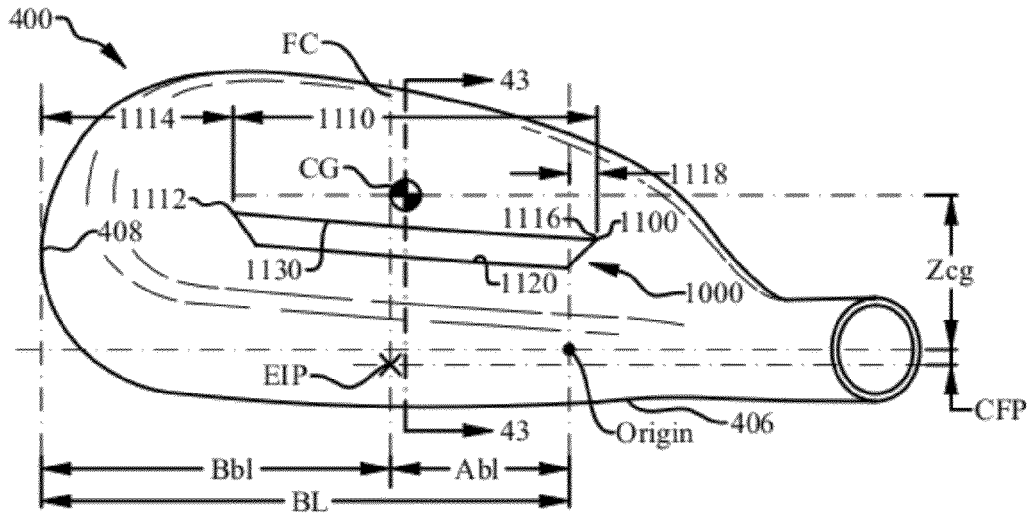

Fig. 42

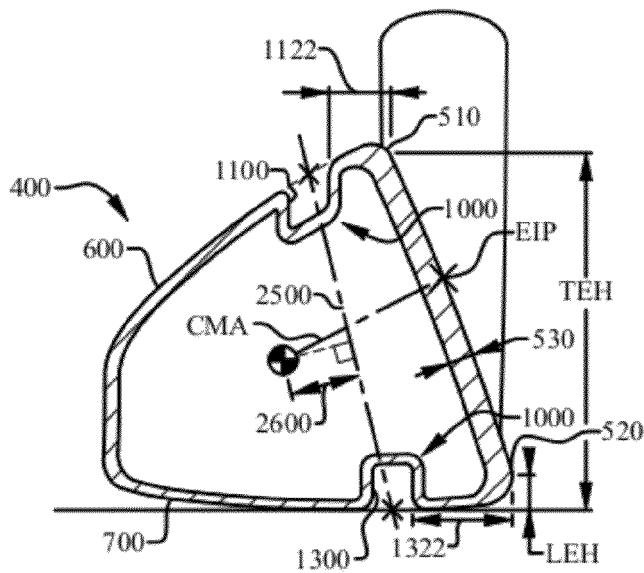

Fig. 43

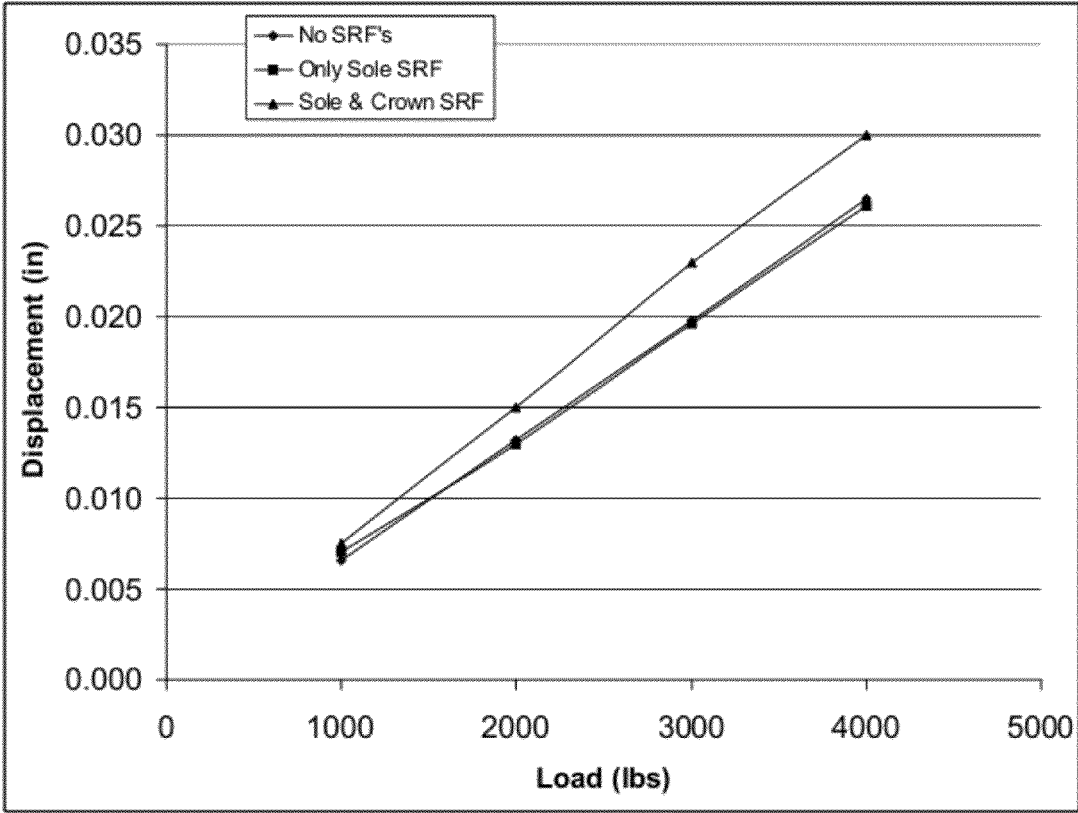

Fig. 44

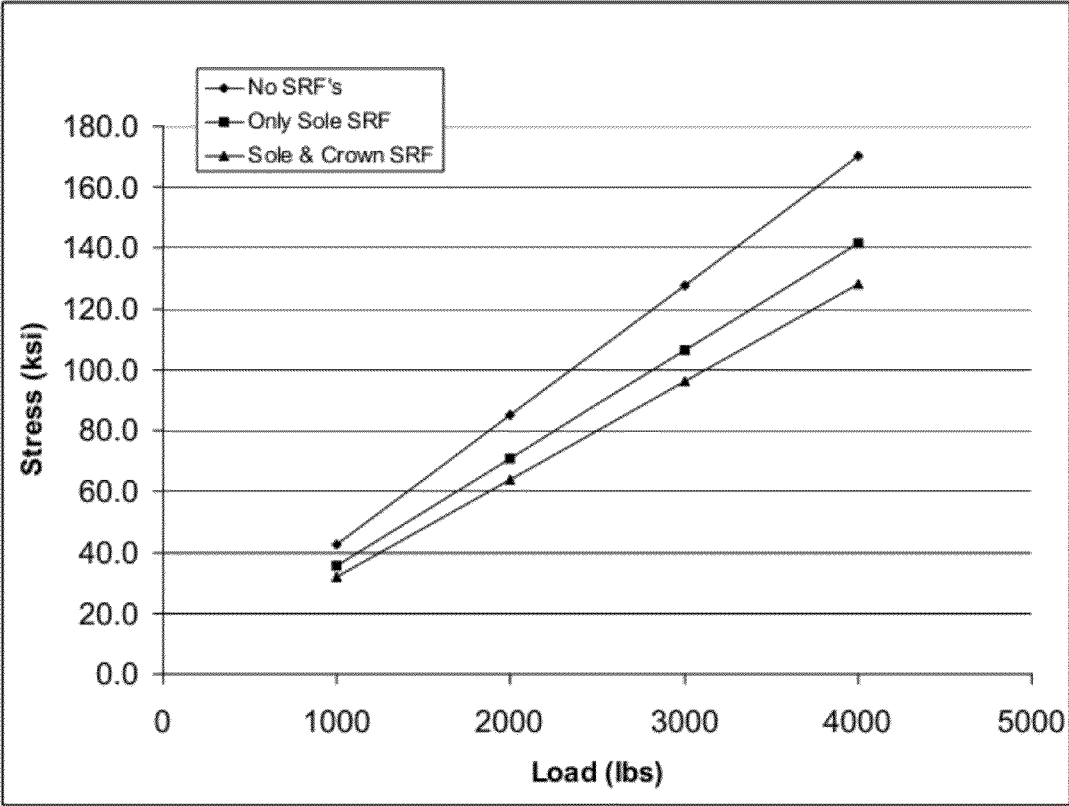

Fig. 45

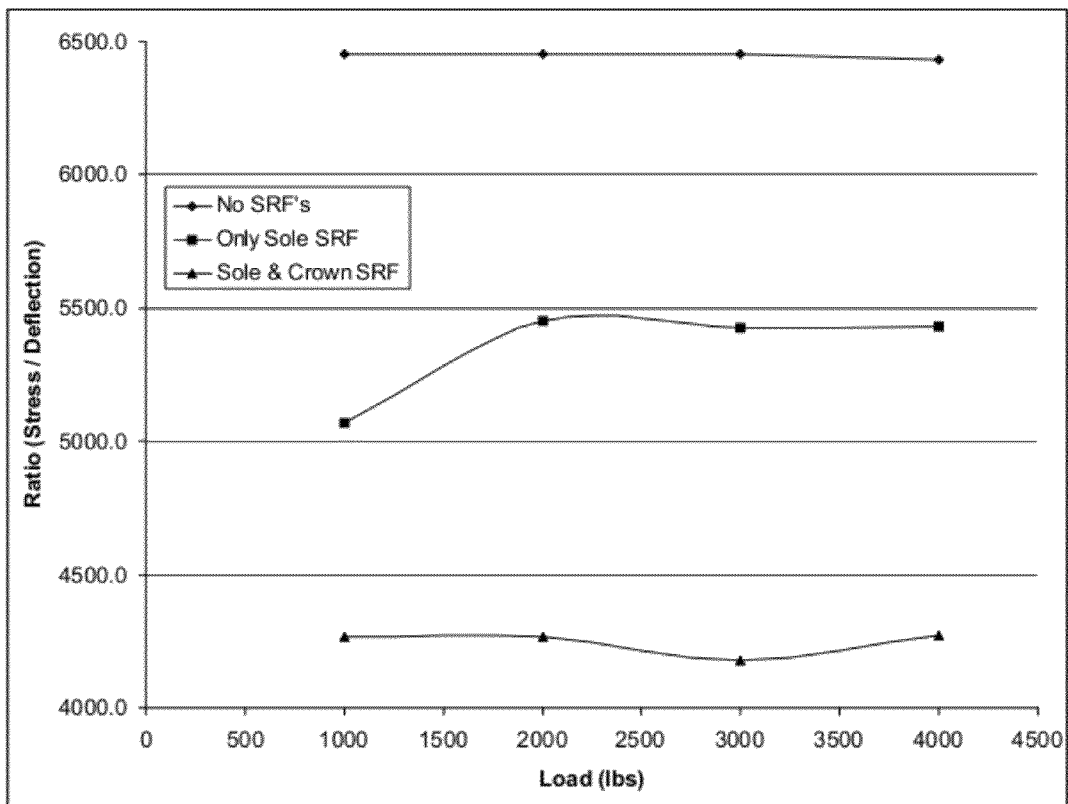
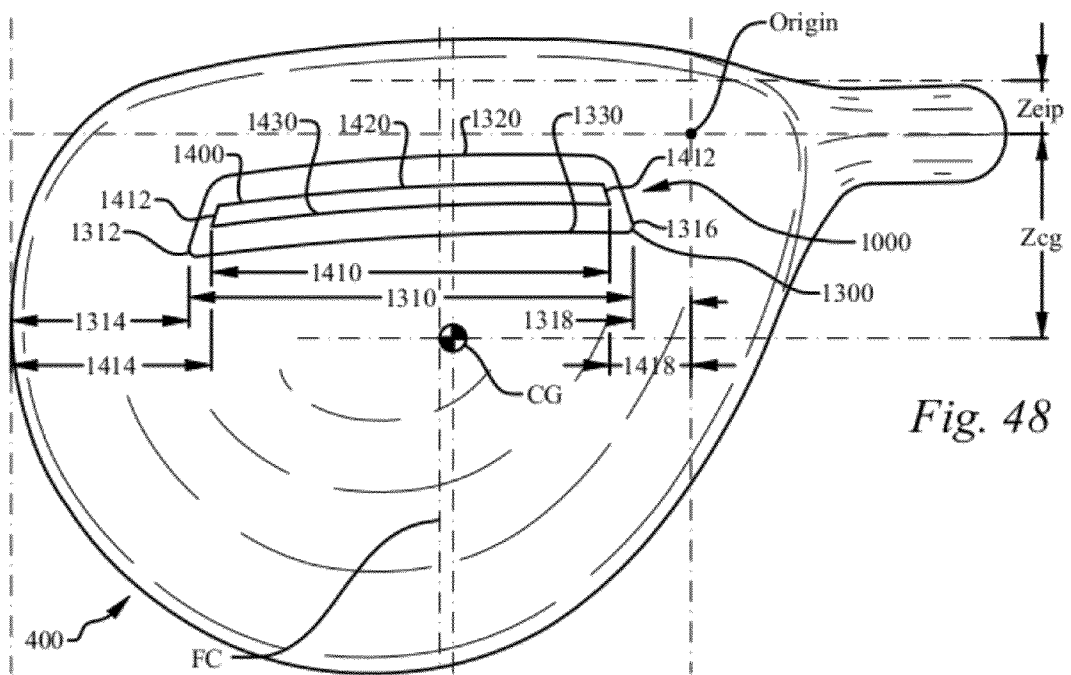
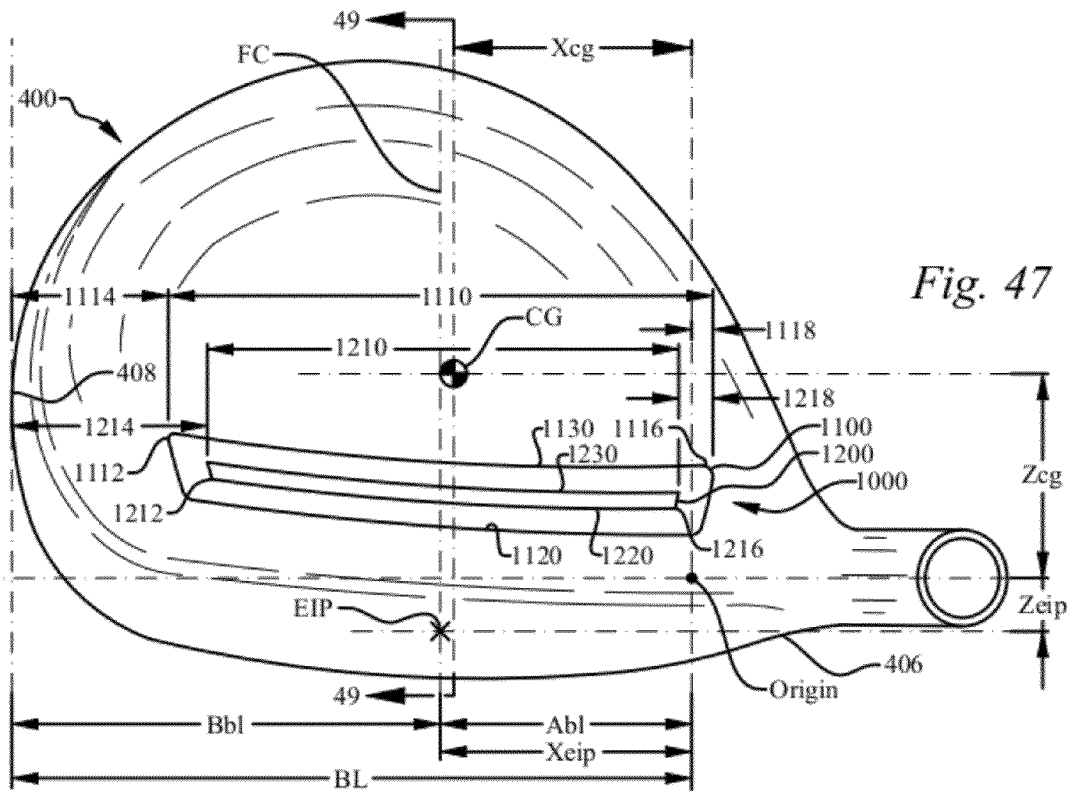

Fig. 46



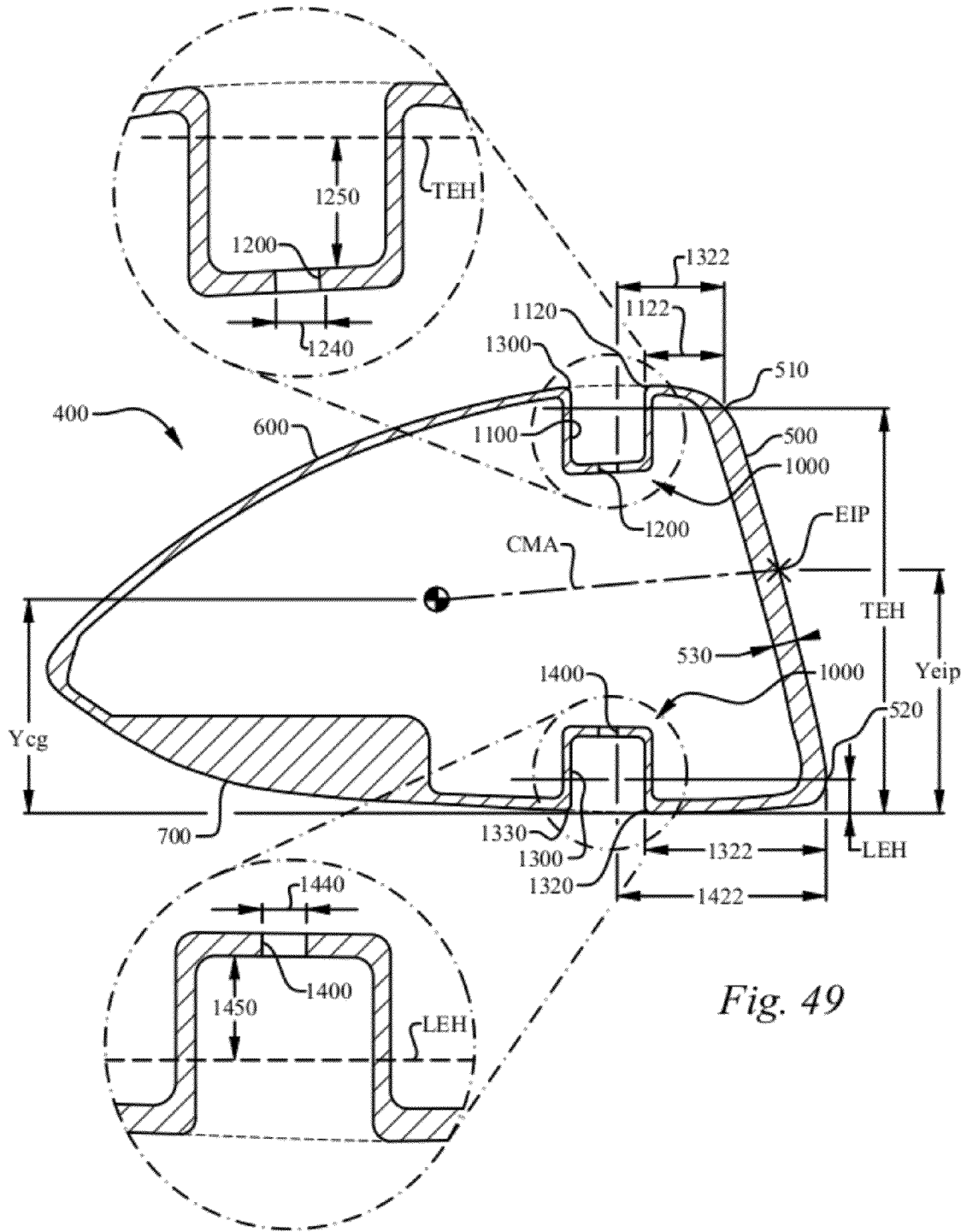

Fig. 49

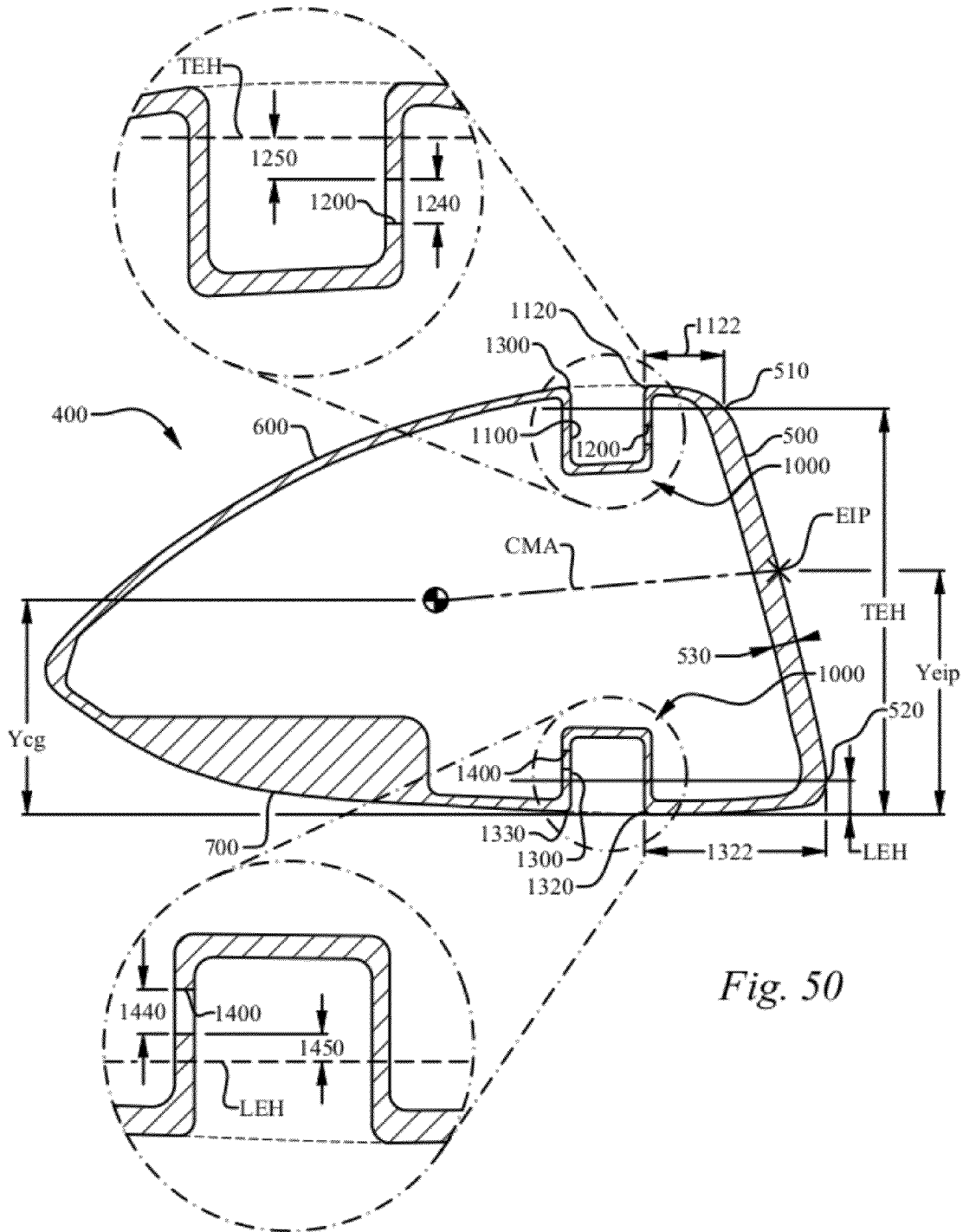

Fig. 50

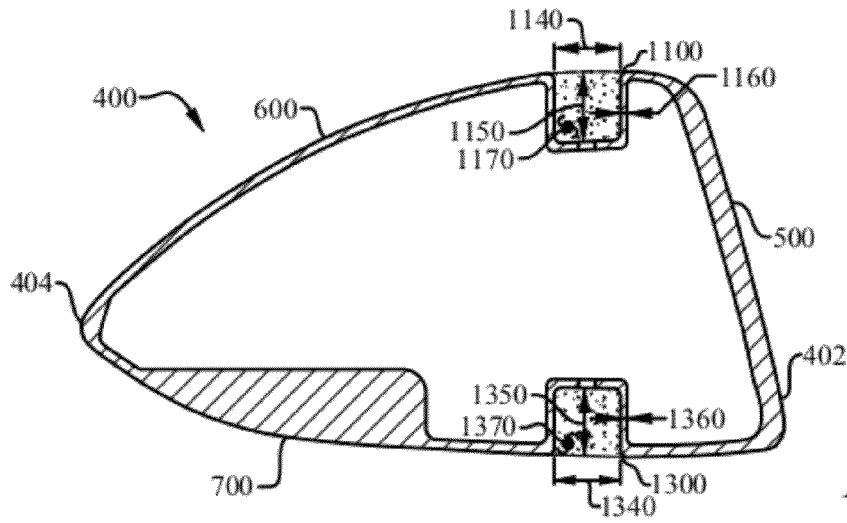

Fig. 51

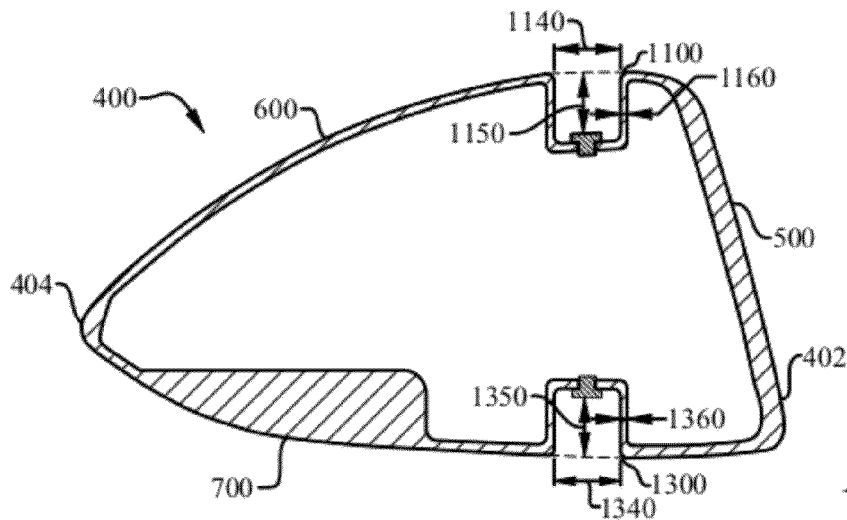

Fig. 52

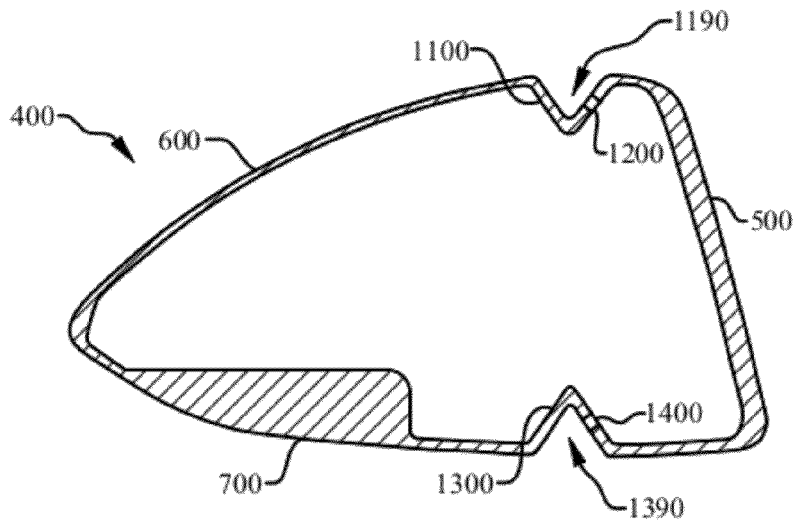

Fig. 53

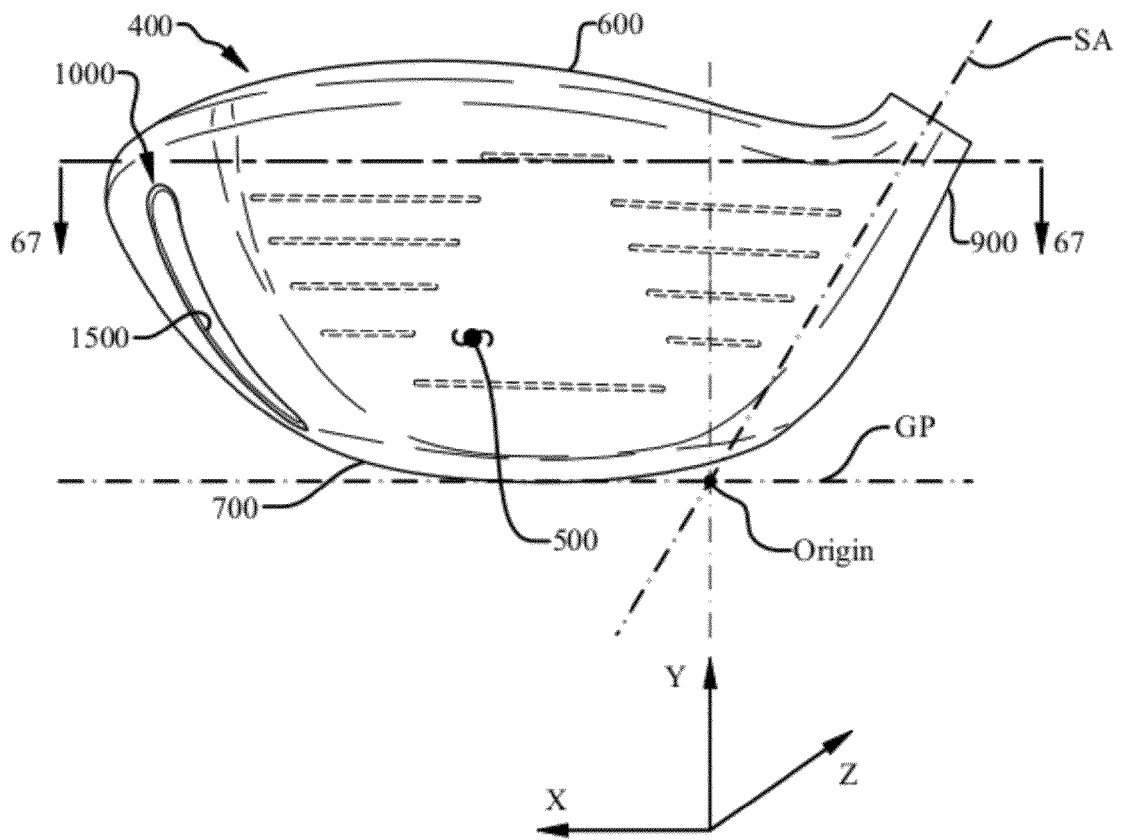

Fig. 54

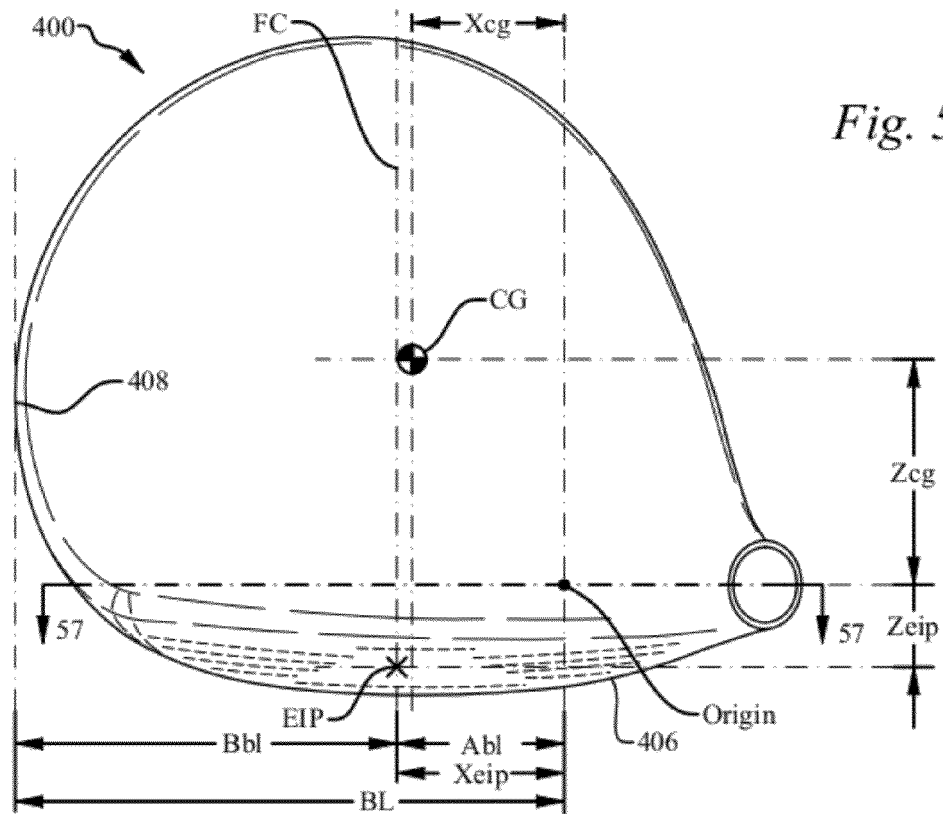

Fig. 55

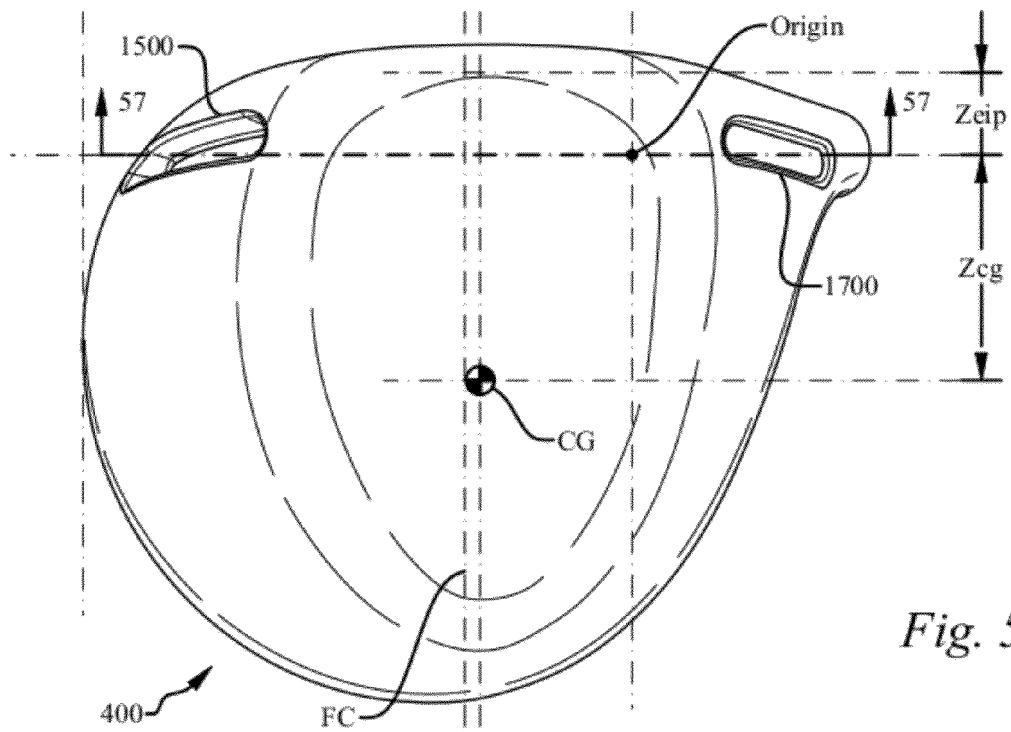

Fig. 56

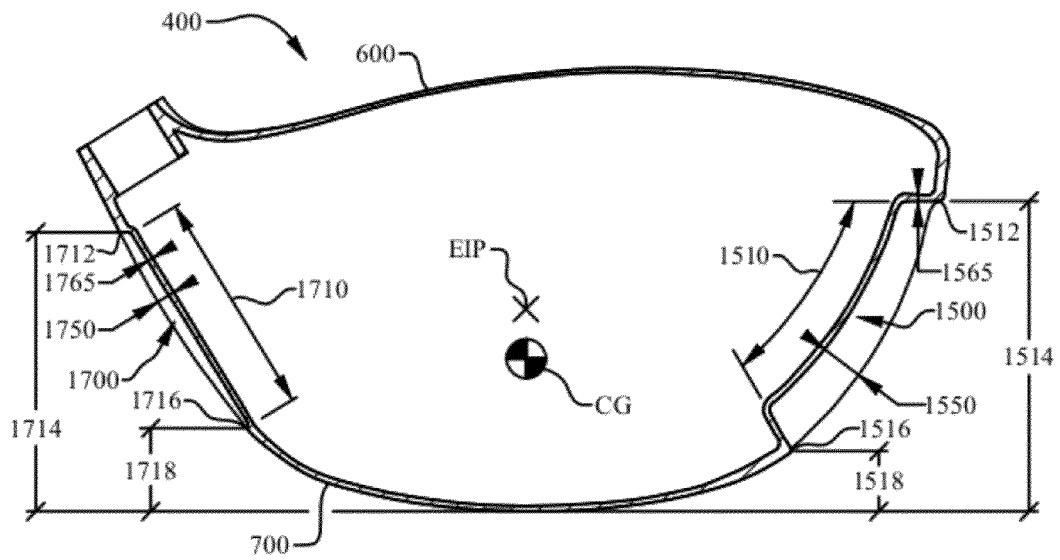

Fig. 57

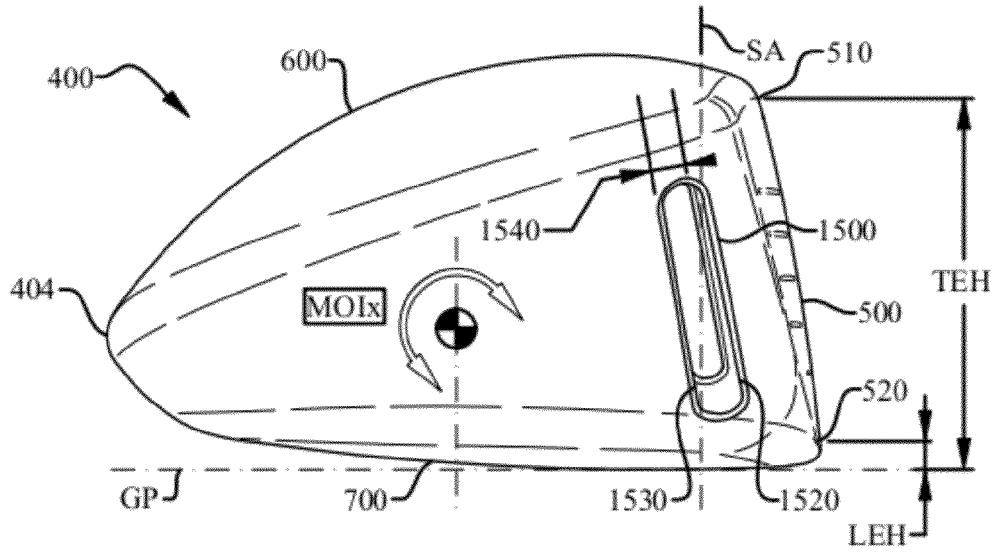

Fig. 58

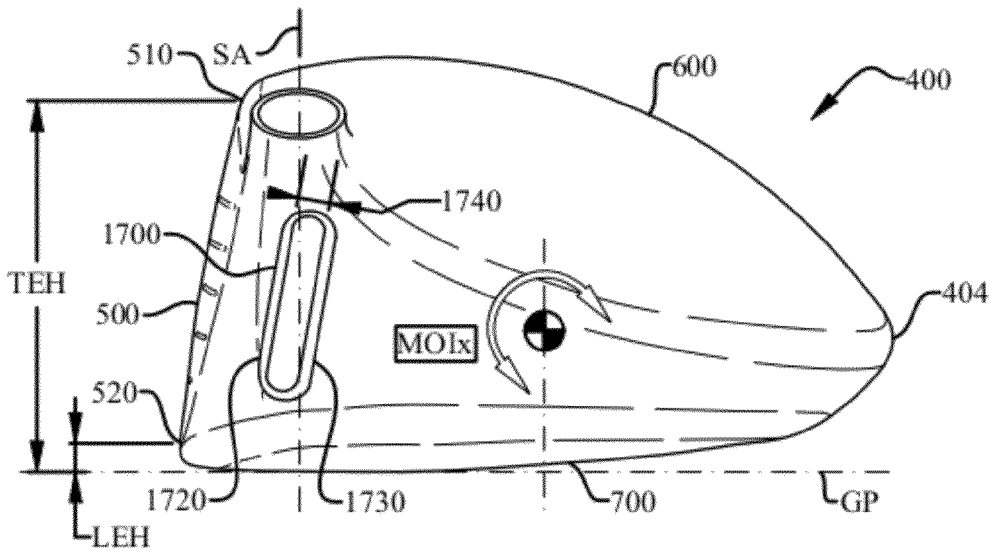

Fig. 59

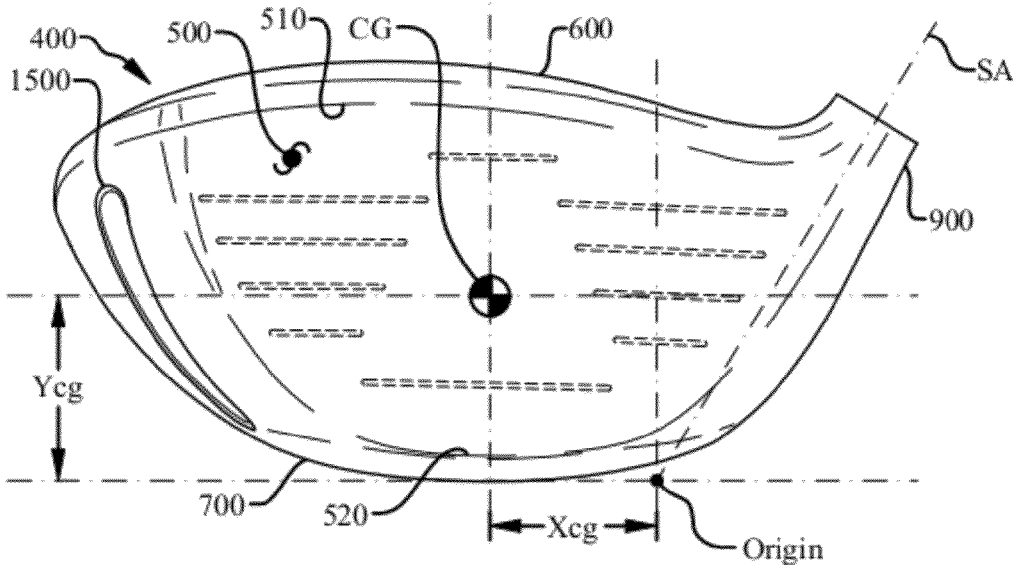

Fig. 60

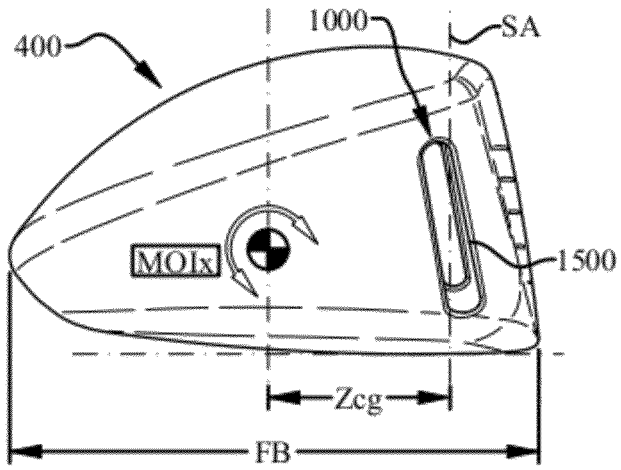

Fig. 61

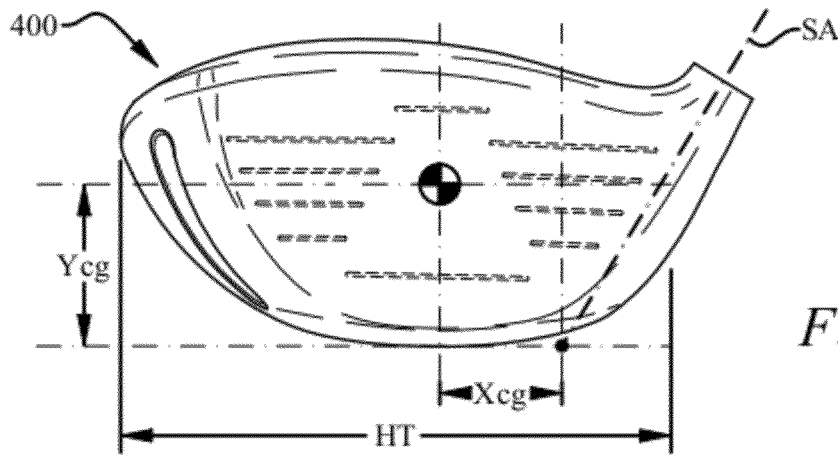

Fig. 62

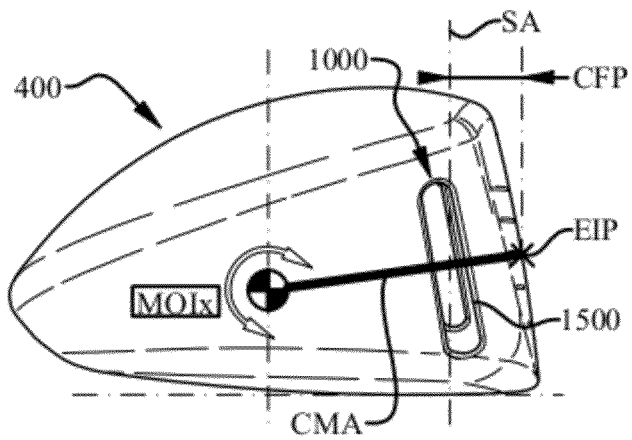

Fig. 63

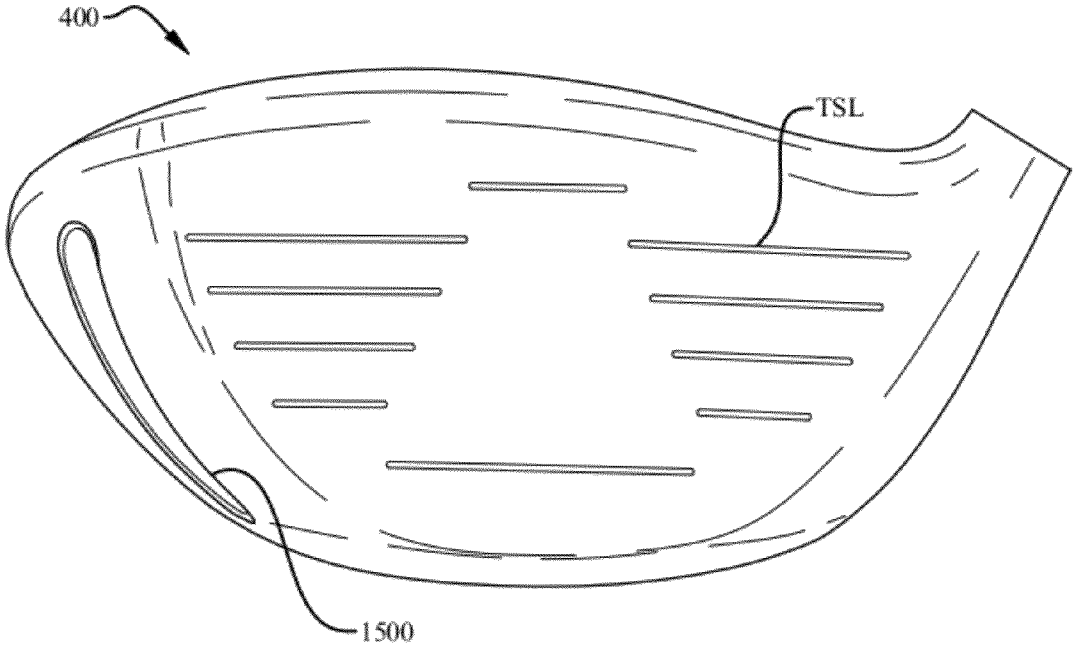

Fig. 64

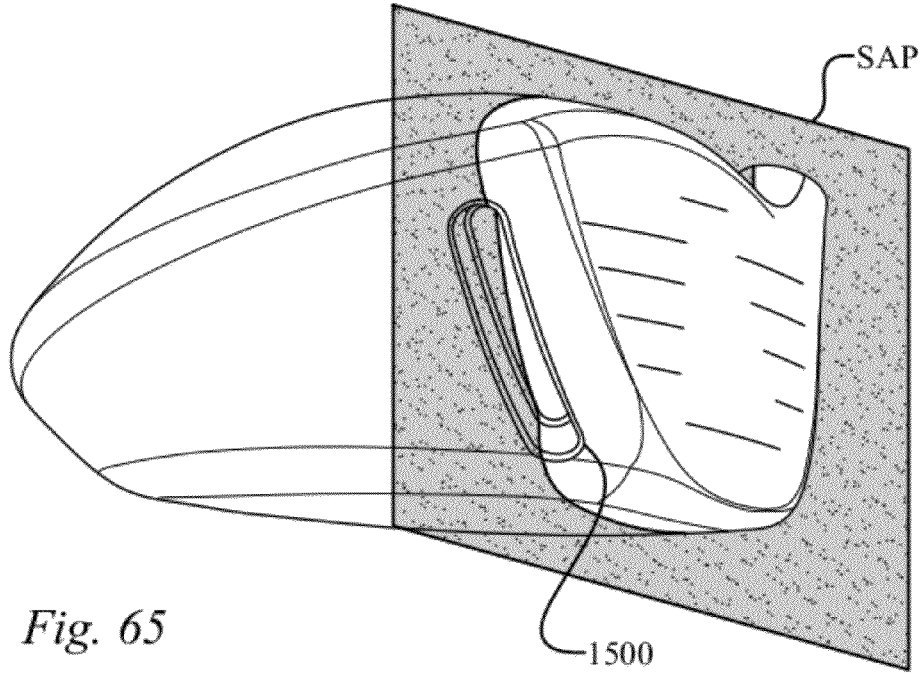

Fig. 65

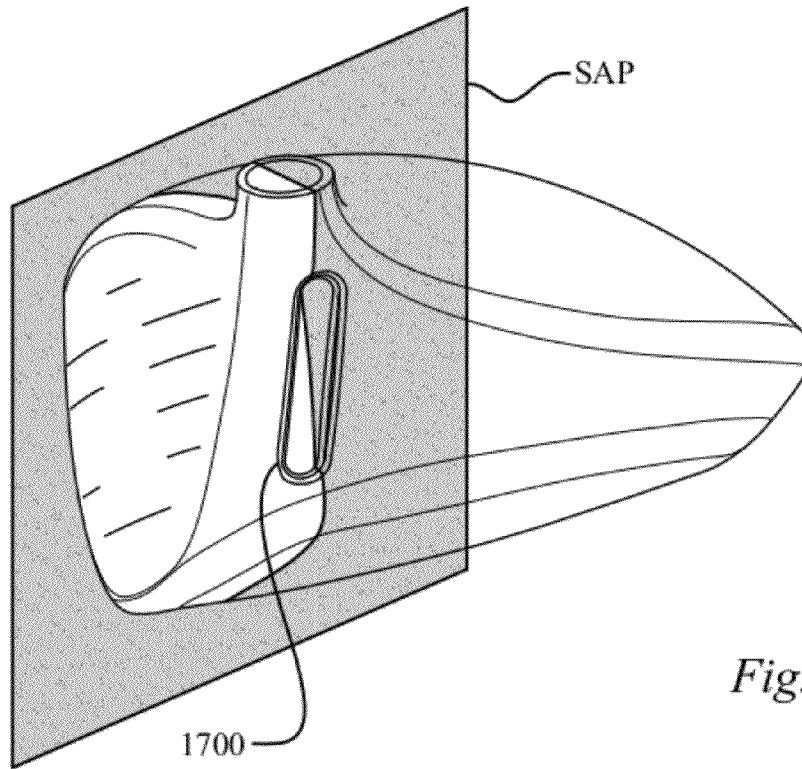

Fig. 66

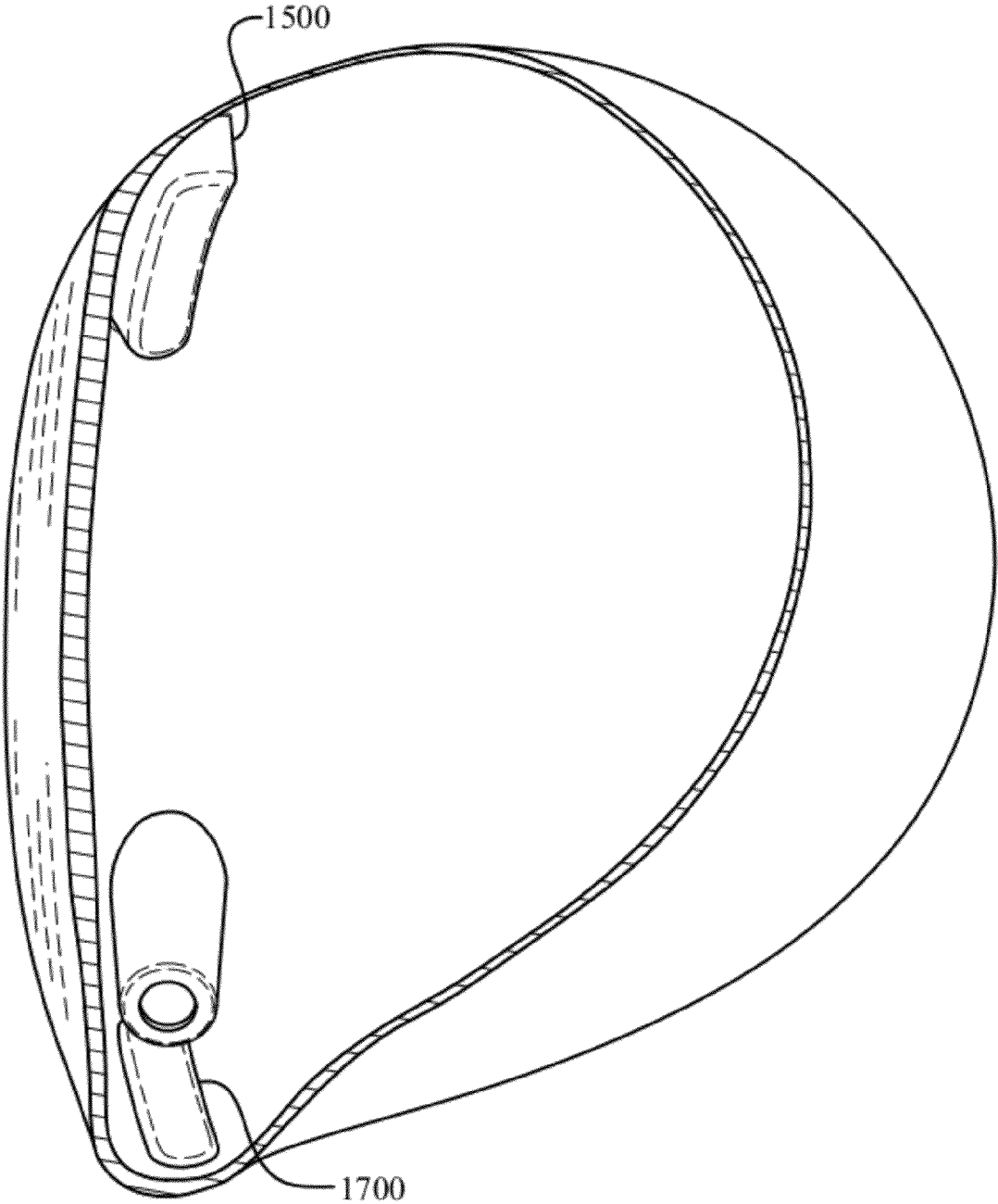

Fig. 67

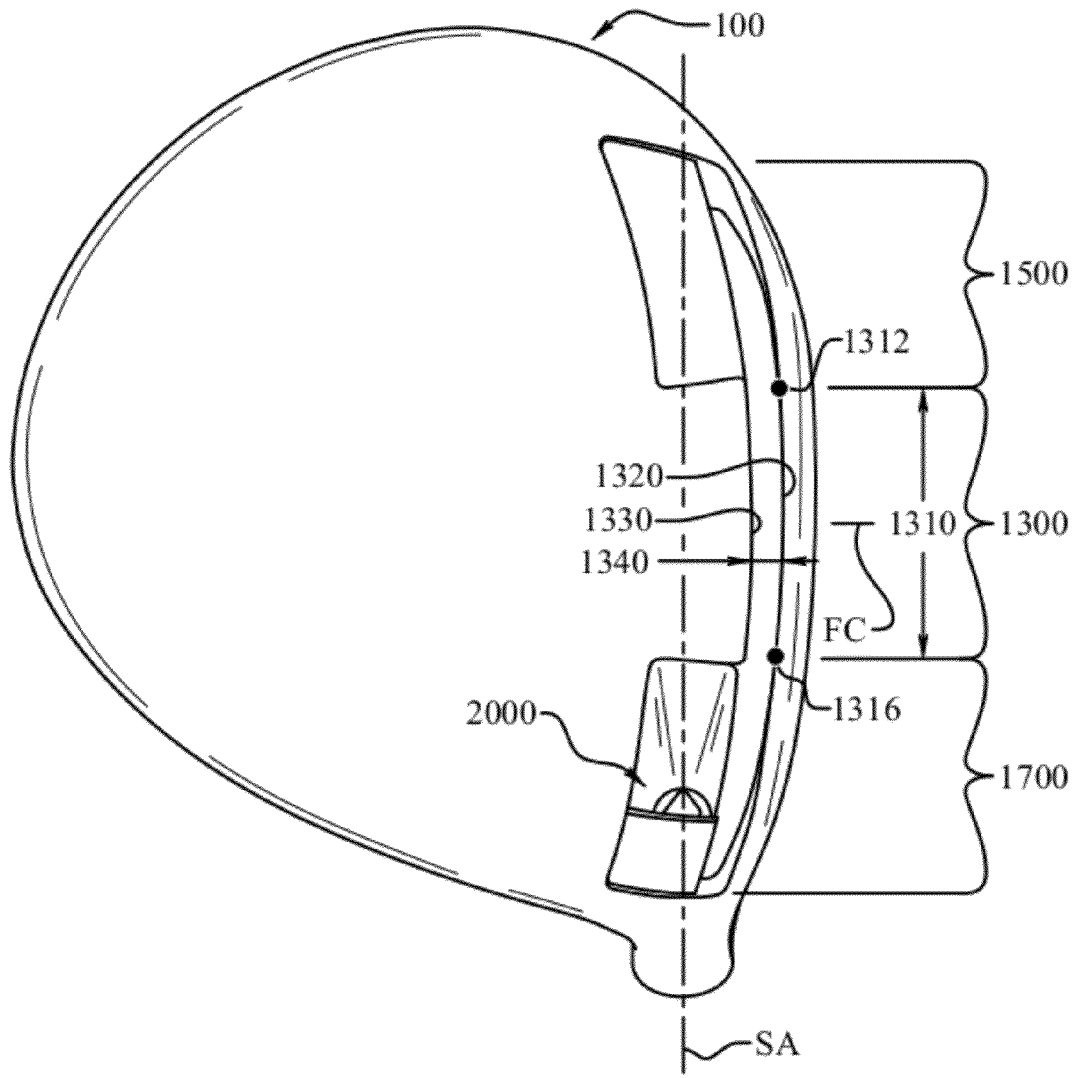

Fig. 68

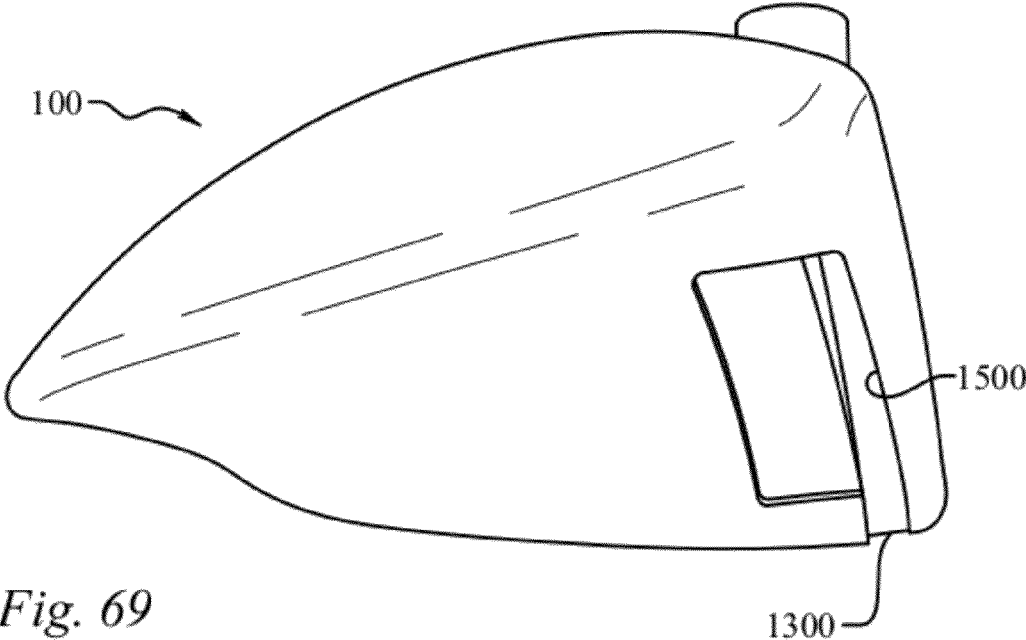

Fig. 69

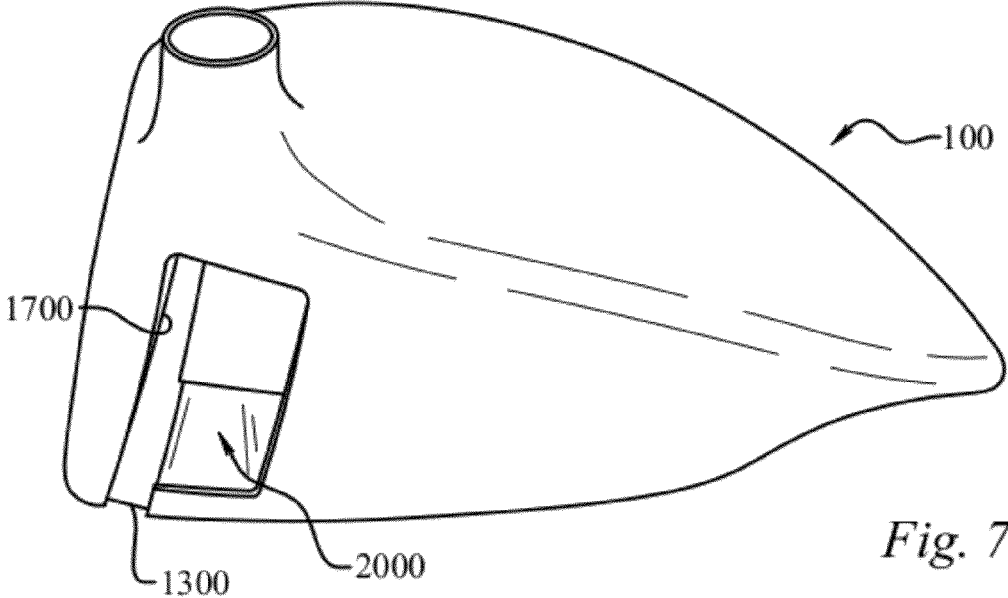

Fig. 70

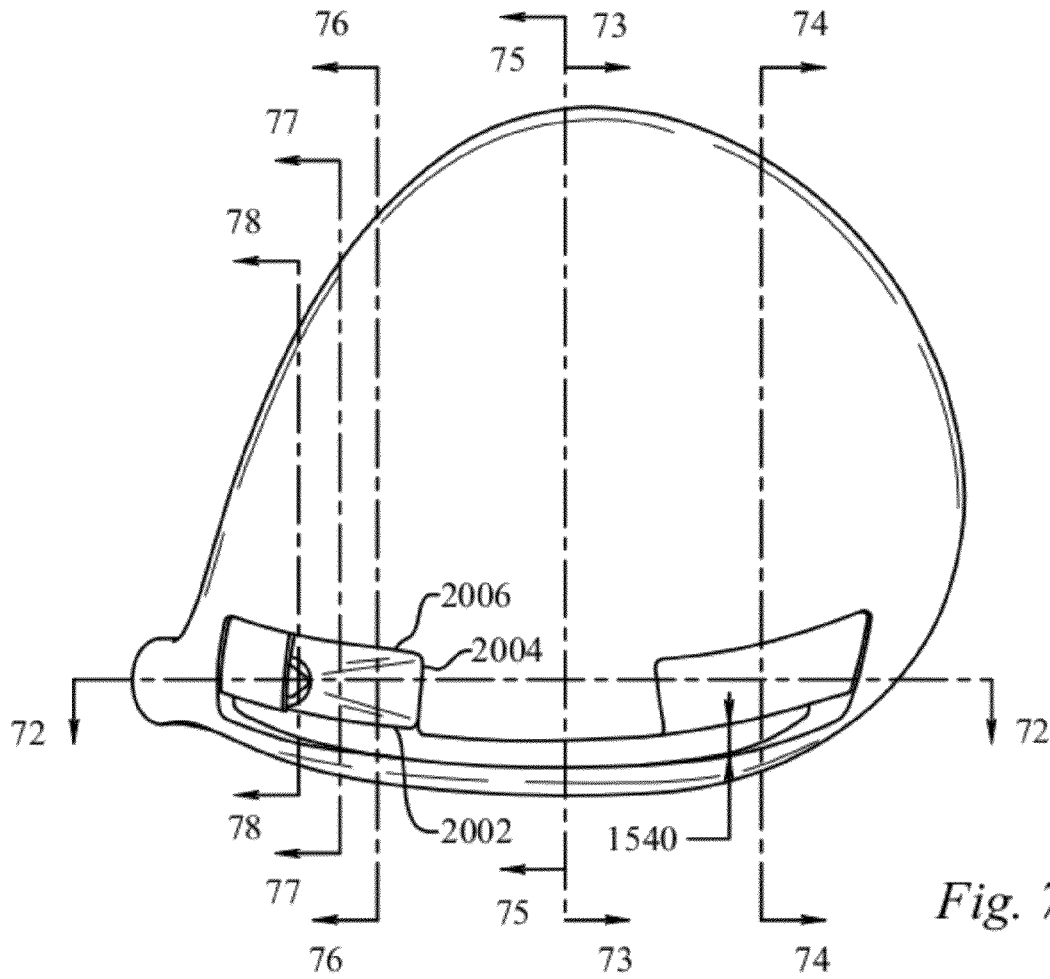

Fig. 71

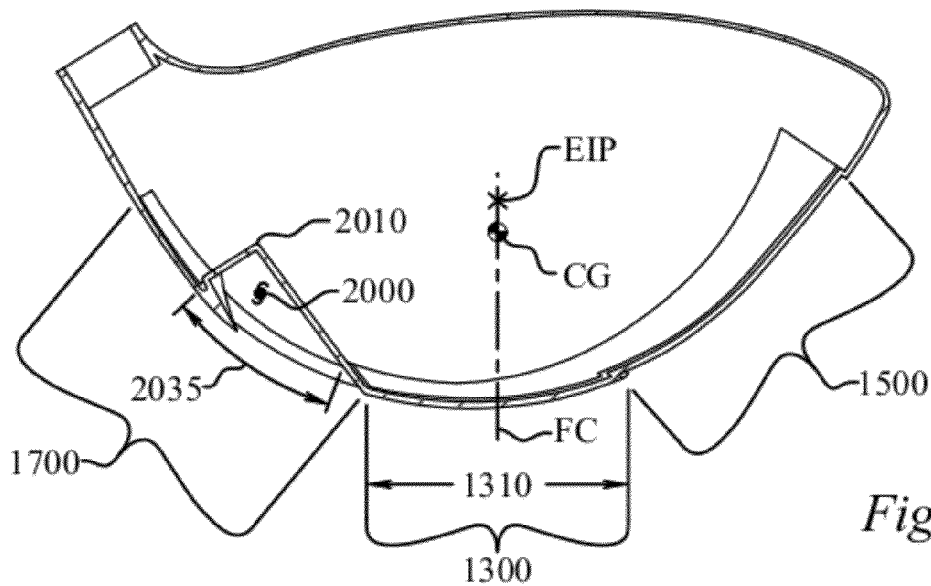

Fig. 72

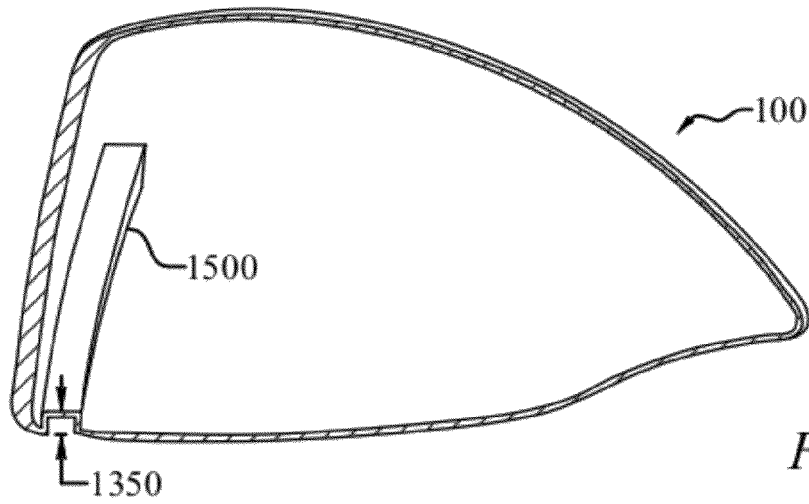

Fig. 73

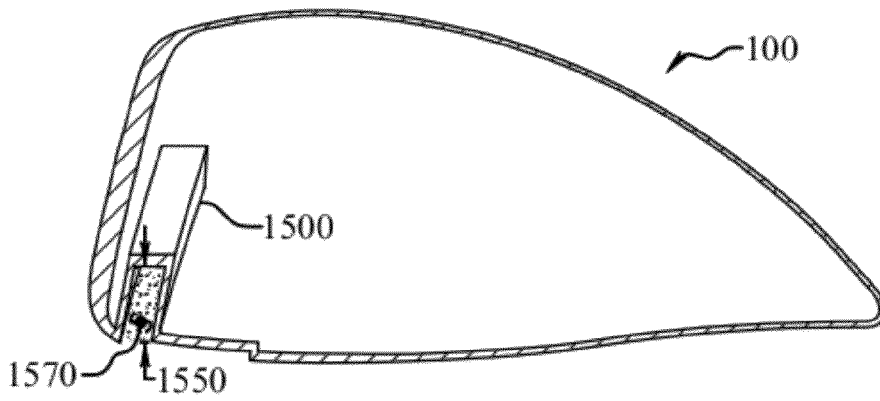

Fig. 74

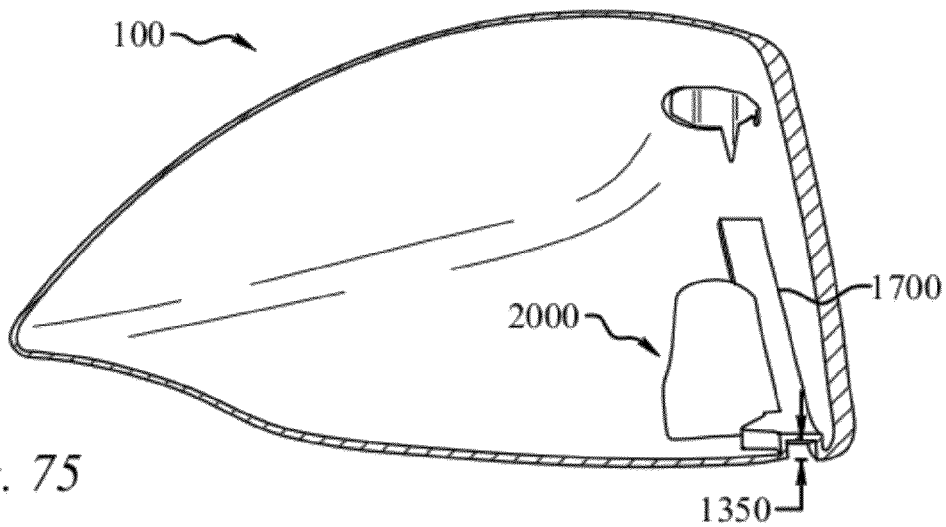

Fig. 75

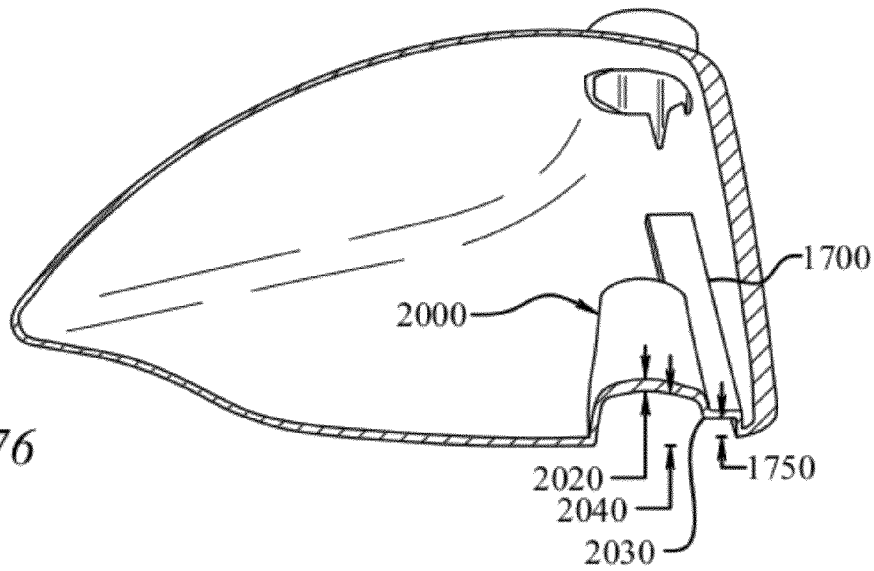

Fig. 76

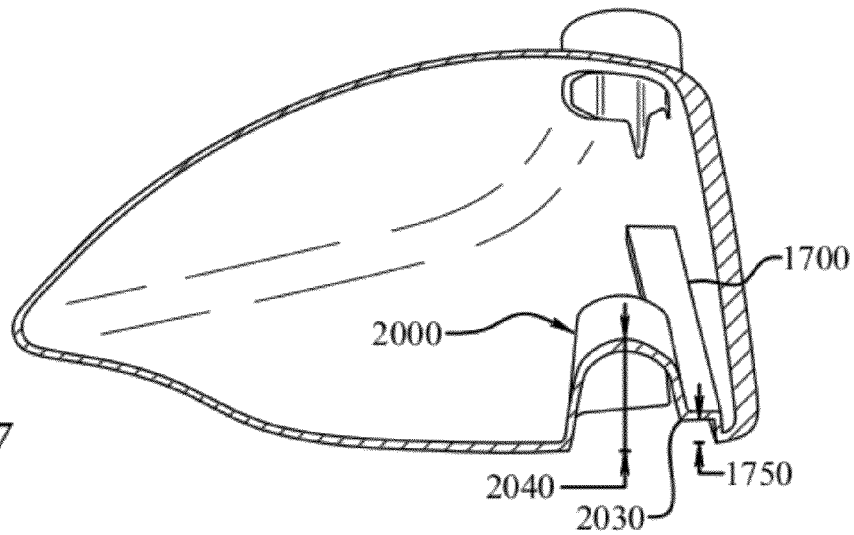

Fig. 77

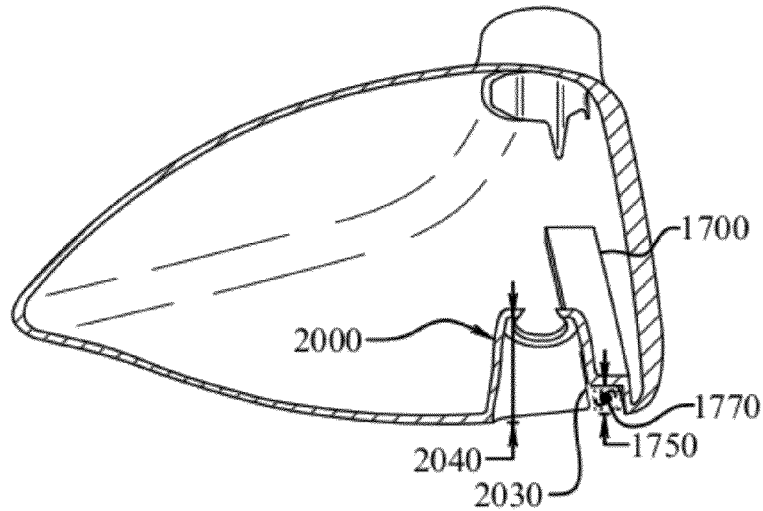

Fig. 78

1

GOLF CLUB HEAD HAVING A STRESS REDUCING FEATURE

CROSS-REFERENCE TO RELATED APPLICATIONS

This application is a continuation-in-part of U.S. patent application Ser. No. 13/397,122, filed on Feb. 15, 2012, which is a continuation-in-part of U.S. patent application Ser. No. 12/791,025, filed on Jun. 1, 2010, now U.S. Pat. No. 8,235,844 all of which are incorporated by reference as if completely written herein.

STATEMENT REGARDING FEDERALLY SPONSORED RESEARCH OR DEVELOPMENT

This invention was not made as part of a federally sponsored research or development project.

TECHNICAL FIELD

The present invention relates to the field of golf clubs, namely hollow golf club heads. The present invention is a hollow golf club head characterized by a stress reducing feature.

BACKGROUND OF THE INVENTION

The impact associated with a golf club head, often moving in excess of 100 miles per hour, impacting a stationary golf ball results in a tremendous force on the face of the golf club head, and accordingly a significant stress on the face. It is desirable to reduce the peak stress experienced by the face and to selectively distribute the force of impact to other areas of the golf club head where it may be more advantageously utilized.

SUMMARY OF INVENTION

In its most general configuration, the present invention advances the state of the art with a variety of new capabilities and overcomes many of the shortcomings of prior methods in new and novel ways. In its most general sense, the present invention overcomes the shortcomings and limitations of the prior art in any of a number of generally effective configurations.

The present golf club incorporating a stress reducing feature including a crown located SRF, short for stress reducing feature, located on the crown of the club head, and/or a sole located SRF located on the sole of the club head, and/or a toe located SRF located along the toe portion of the club head, and/or a heel located SRF located along the heel portion of the club head. Any of the SRF's may contain an aperture extending through the shell of the golf club head. The location and size of the SRF and aperture play a significant role in reducing the peak stress seen on the golf club's face during an impact with a golf ball, as well as selectively increasing deflection of the face.

Numerous variations, modifications, alternatives, and alterations of the various preferred embodiments, processes, and methods may be used alone or in combination with one another as will become more readily apparent to those with skill in the art with reference to the following detailed description of the preferred embodiments and the accompanying figures and drawings.

BRIEF DESCRIPTION OF THE DRAWINGS

Without limiting the scope of the present invention as claimed below and referring now to the drawings and figures:

2

FIG. 1 shows a front elevation view of an embodiment of the present invention, not to scale;

FIG. 2 shows a top plan view of an embodiment of the present invention, not to scale;

5 FIG. 3 shows a front elevation view of an embodiment of the present invention, not to scale;

FIG. 4 shows a toe side elevation view of an embodiment of the present invention, not to scale;

10 FIG. 5 shows a top plan view of an embodiment of the present invention, not to scale;

FIG. 6 shows a toe side elevation view of an embodiment of the present invention, not to scale;

15 FIG. 7 shows a front elevation view of an embodiment of the present invention, not to scale;

FIG. 8 shows a toe side elevation view of an embodiment of the present invention, not to scale;

FIG. 9 shows a front elevation view of an embodiment of the present invention, not to scale;

20 FIG. 10 shows a front elevation view of an embodiment of the present invention, not to scale;

FIG. 11 shows a front elevation view of an embodiment of the present invention, not to scale;

25 FIG. 12 shows a front elevation view of an embodiment of the present invention, not to scale;

FIG. 13 shows a front elevation view of an embodiment of the present invention, not to scale;

30 FIG. 14 shows a top plan view of an embodiment of the present invention, not to scale;

FIG. 15 shows a front elevation view of an embodiment of the present invention, not to scale;

35 FIG. 16 shows a top plan view of an embodiment of the present invention, not to scale;

FIG. 17 shows a top plan view of an embodiment of the present invention, not to scale;

40 FIG. 18 shows a top plan view of an embodiment of the present invention, not to scale;

FIG. 19 shows a front elevation view of an embodiment of the present invention, not to scale;

45 FIG. 20 shows a toe side elevation view of an embodiment of the present invention, not to scale;

FIG. 21 shows a front elevation view of an embodiment of the present invention, not to scale;

50 FIG. 22 shows a top plan view of an embodiment of the present invention, not to scale;

FIG. 23 shows a bottom plan view of an embodiment of the present invention, not to scale;

55 FIG. 24 shows a partial cross-sectional view of an embodiment of the present invention, not to scale;

FIG. 25 shows a partial cross-sectional view of an embodiment of the present invention, not to scale;

60 FIG. 26 shows a partial cross-sectional view of an embodiment of the present invention, not to scale;

FIG. 27 shows a partial cross-sectional view of an embodiment of the present invention, not to scale;

65 FIG. 28 shows a partial cross-sectional view of an embodiment of the present invention, not to scale;

FIG. 29 shows a partial cross-sectional view of an embodiment of the present invention, not to scale;

70 FIG. 30 shows a top plan view of an embodiment of the present invention, not to scale;

FIG. 31 shows a bottom plan view of an embodiment of the present invention, not to scale;

75 FIG. 32 shows a top plan view of an embodiment of the present invention, not to scale;

FIG. 33 shows a bottom plan view of an embodiment of the present invention, not to scale;

FIG. 34 shows a partial cross-sectional view of an embodiment of the present invention, not to scale;

FIG. 35 shows a partial cross-sectional view of an embodiment of the present invention, not to scale;

FIG. 36 shows a top plan view of an embodiment of the present invention, not to scale;

FIG. 37 shows a bottom plan view of an embodiment of the present invention, not to scale;

FIG. 38 shows a partial cross-sectional view of an embodiment of the present invention, not to scale;

FIG. 39 shows a partial cross-sectional view of an embodiment of the present invention, not to scale;

FIG. 40 shows a partial cross-sectional view of an embodiment of the present invention, not to scale;

FIG. 41 shows a partial cross-sectional view of an embodiment of the present invention, not to scale;

FIG. 42 shows a top plan view of an embodiment of the present invention, not to scale;

FIG. 43 shows a partial cross-sectional view of an embodiment of the present invention, not to scale;

FIG. 44 shows a graph of face displacement versus load;

FIG. 45 shows a graph of peak stress on the face versus load;

FIG. 46 shows a graph of the stress-to-deflection ratio versus load;

FIG. 47 shows a top plan view of an embodiment of the present invention, not to scale;

FIG. 48 shows a bottom plan view of an embodiment of the present invention, not to scale;

FIG. 49 shows a partial cross-sectional view of an embodiment of the present invention, not to scale;

FIG. 50 shows a partial cross-sectional view of an embodiment of the present invention, not to scale;

FIG. 51 shows a partial cross-sectional view of an embodiment of the present invention, not to scale;

FIG. 52 shows a partial cross-sectional view of an embodiment of the present invention, not to scale;

FIG. 53 shows a partial cross-sectional view of an embodiment of the present invention, not to scale;

FIG. 54 shows a front elevation view of an embodiment of the present invention, not to scale;

FIG. 55 shows a top plan view of an embodiment of the present invention, not to scale;

FIG. 56 shows a bottom plan view of an embodiment of the present invention, not to scale;

FIG. 57 shows a cross-sectional view, taken along section line 57-57 in FIG. 56, of an embodiment of the present invention, not to scale;

FIG. 58 shows a toe side elevation view of an embodiment of the present invention, not to scale;

FIG. 59 shows a heel side elevation view of an embodiment of the present invention, not to scale;

FIG. 60 shows a front elevation view of an embodiment of the present invention, not to scale;

FIG. 61 shows a toe side elevation view of an embodiment of the present invention, not to scale;

FIG. 62 shows a front elevation view of an embodiment of the present invention, not to scale;

FIG. 63 shows a toe side elevation view of an embodiment of the present invention, not to scale;

FIG. 64 shows a front elevation view of an embodiment of the present invention, not to scale;

FIG. 65 shows a rotated perspective view of an embodiment of the present invention, not to scale;

FIG. 66 shows a rotated perspective view of an embodiment of the present invention, not to scale;

FIG. 67 shows a cross-sectional view, taken along section line 67-67 in FIG. 54, of an embodiment of the present invention, not to scale;

FIG. 68 shows a bottom plan view of an embodiment of the present invention, not to scale;

FIG. 69 shows a toe side elevation view of an embodiment of the present invention, not to scale;

FIG. 70 shows a heel side elevation view of an embodiment of the present invention, not to scale;

FIG. 71 shows a bottom plan view of an embodiment of the present invention, not to scale;

FIG. 72 shows a cross-sectional view, taken along section line 72-72 in FIG. 71, of an embodiment of the present invention, not to scale;

FIG. 73 shows a cross-sectional view, taken along section line 73-73 in FIG. 71, of an embodiment of the present invention, not to scale;

FIG. 74 shows a cross-sectional view, taken along section line 74-74 in FIG. 71, of an embodiment of the present invention, not to scale;

FIG. 75 shows a cross-sectional view, taken along section line 75-75 in FIG. 71, of an embodiment of the present invention, not to scale;

FIG. 76 shows a cross-sectional view, taken along section line 76-76 in FIG. 71, of an embodiment of the present invention, not to scale;

FIG. 77 shows a cross-sectional view, taken along section line 77-77 in FIG. 71, of an embodiment of the present invention, not to scale; and

FIG. 78 shows a cross-sectional view, taken along section line 78-78 in FIG. 71, of an embodiment of the present invention, not to scale.

These drawings are provided to assist in the understanding of the exemplary embodiments of the present golf club as described in more detail below and should not be construed as unduly limiting the golf club. In particular, the relative spacing, positioning, sizing and dimensions of the various elements illustrated in the drawings are not drawn to scale and may have been exaggerated, reduced or otherwise modified for the purpose of improved clarity. Those of ordinary skill in the art will also appreciate that a range of alternative configurations have been omitted simply to improve the clarity and reduce the number of drawings.

DETAILED DESCRIPTION OF THE INVENTION

The hollow golf club of the present invention enables a significant advance in the state of the art. The preferred embodiments of the golf club accomplish this by new and novel methods that are configured in unique and novel ways and which demonstrate previously unavailable, but preferred and desirable capabilities. The description set forth below in connection with the drawings is intended merely as a description of the presently preferred embodiments of the golf club, and is not intended to represent the only form in which the present golf club may be constructed or utilized. The description sets forth the designs, functions, means, and methods of implementing the golf club in connection with the illustrated embodiments. It is to be understood, however, that the same or equivalent functions and features may be accomplished by different embodiments that are also intended to be encompassed within the spirit and scope of the claimed golf club head.

In order to fully appreciate the present disclosed golf club some common terms must be defined for use herein. First, one of skill in the art will know the meaning of "center of gravity," referred to herein as CG, from an entry level course on the

mechanics of solids. With respect to wood-type golf clubs, hybrid golf clubs, and hollow iron type golf clubs, which are may have non-uniform density, the CG is often thought of as the intersection of all the balance points of the club head. In other words, if you balance the head on the face and then on the sole, the intersection of the two imaginary lines passing straight through the balance points would define the point referred to as the CG.

It is helpful to establish a coordinate system to identify and discuss the location of the CG. In order to establish this coordinate system one must first identify a ground plane (GP) and a shaft axis (SA). First, the ground plane (GP) is the horizontal plane upon which a golf club head rests, as seen best in a front elevation view of a golf club head looking at the face of the golf club head, as seen in FIG. 1. Secondly, the shaft axis (SA) is the axis of a bore in the golf club head that is designed to receive a shaft. Some golf club heads have an external hosel that contains a bore for receiving the shaft such that one skilled in the art can easily appreciate the shaft axis (SA), while other "hosel-less" golf clubs have an internal bore that receives the shaft that nonetheless defines the shaft axis (SA). The shaft axis (SA) is fixed by the design of the golf club head and is also illustrated in FIG. 1.

Now, the intersection of the shaft axis (SA) with the ground plane (GP) fixes an origin point, labeled "origin" in FIG. 1, for the coordinate system. While it is common knowledge in the industry, it is worth noting that the right side of the club head seen in FIG. 1, the side nearest the bore in which the shaft attaches, is the "heel" side, or portion, of the golf club head; and the opposite side, the left side in FIG. 1, is referred to as the "toe" side, or portion, of the golf club head. Additionally, the portion of the golf club head that actually strikes a golf ball is referred to as the face of the golf club head and is commonly referred to as the front of the golf club head; whereas the opposite end of the golf club head is referred to as the rear of the golf club head and/or the trailing edge.

A three dimensional coordinate system may now be established from the origin with the Y-direction being the vertical direction from the origin; the X-direction being the horizontal direction perpendicular to the Y-direction and wherein the X-direction is parallel to the face of the golf club head in the natural resting position, also known as the design position; and the Z-direction is perpendicular to the X-direction wherein the Z-direction is the direction toward the rear of the golf club head. The X, Y, and Z directions are noted on a coordinate system symbol in FIG. 1. It should be noted that this coordinate system is contrary to the traditional right-hand rule coordinate system; however it is preferred so that the center of gravity may be referred to as having all positive coordinates.

Now, with the origin and coordinate system defined, the terms that define the location of the CG may be explained. One skilled in the art will appreciate that the CG of a hollow golf club head such as the wood-type golf club head illustrated in FIG. 2 will be behind the face of the golf club head. The distance behind the origin that the CG is located is referred to as Zcg, as seen in FIG. 2. Similarly, the distance above the origin that the CG is located is referred to as Ycg, as seen in FIG. 3. Lastly, the horizontal distance from the origin that the CG is located is referred to as Xcg, also seen in FIG. 3. Therefore, the location of the CG may be easily identified by reference to Xcg, Ycg, and Zcg.

The moment of inertia of the golf club head is a key ingredient in the playability of the club. Again, one skilled in the art will understand what is meant by moment of inertia with respect to golf club heads; however it is helpful to define two moment of inertia components that will be commonly

referred to herein. First, MOIx is the moment of inertia of the golf club head around an axis through the CG, parallel to the X-axis, labeled in FIG. 4. MOIx is the moment of inertia of the golf club head that resists lofting and delofting moments induced by ball strikes high or low on the face. Secondly, MOIy is the moment of the inertia of the golf club head around an axis through the CG, parallel to the Y-axis, labeled in FIG. 5. MOIy is the moment of inertia of the golf club head that resists opening and closing moments induced by ball strikes towards the toe side or heel side of the face.

Continuing with the definitions of key golf club head dimensions, the "front-to-back" dimension, referred to as the FB dimension, is the distance from the furthest forward point at the leading edge of the golf club head to the furthest rearward point at the rear of the golf club head, i.e. the trailing edge, as seen in FIG. 6. The "heel-to-toe" dimension, referred to as the HT dimension, is the distance from the point on the surface of the club head on the toe side that is furthest from the origin in the X-direction, to the point on the surface of the golf club head on the heel side that is 0.875" above the ground plane and furthest from the origin in the negative X-direction, as seen in FIG. 7.

A key location on the golf club face is an engineered impact point (EIP). The engineered impact point (EIP) is important in that it helps define several other key attributes of the present golf club head. The engineered impact point (EIP) is generally thought of as the point on the face that is the ideal point at which to strike the golf ball. Generally, the score lines on golf club heads enable one to easily identify the engineered impact point (EIP) for a golf club. In the embodiment of FIG. 9, the first step in identifying the engineered impact point (EIP) is to identify the top score line (TSL) and the bottom score line (BSL). Next, draw an imaginary line (IL) from the midpoint of the top score line (TSL) to the midpoint of the bottom score line (BSL). This imaginary line (IL) will often not be vertical since many score line designs are angled upward toward the toe when the club is in the natural position. Next, as seen in FIG. 10, the club must be rotated so that the top score line (TSL) and the bottom score line (BSL) are parallel with the ground plane (GP), which also means that the imaginary line (IL) will now be vertical. In this position, the leading edge height (LEH) and the top edge height (TEH) are measured from the ground plane (GP). Next, the face height is determined by subtracting the leading edge height (LEH) from the top edge height (TEH). The face height is then divided in half and added to the leading edge height (LEH) to yield the height of the engineered impact point (EIP). Continuing with the club head in the position of FIG. 10, a spot is marked on the imaginary line (IL) at the height above the ground plane (GP) that was just calculated. This spot is the engineered impact point (EIP).

The engineered impact point (EIP) may also be easily determined for club heads having alternative score line configurations. For instance, the golf club head of FIG. 11 does not have a centered top score line. In such a situation, the two outermost score lines that have lengths within 5% of one another are then used as the top score line (TSL) and the bottom score line (BSL). The process for determining the location of the engineered impact point (EIP) on the face is then determined as outlined above. Further, some golf club heads have non-continuous score lines, such as that seen at the top of the club head face in FIG. 12. In this case, a line is extended across the break between the two top score line sections to create a continuous top score line (TSL). The newly created continuous top score line (TSL) is then bisected and used to locate the imaginary line (IL). Again,

then the process for determining the location of the engineered impact point (EIP) on the face is determined as outlined above.

The engineered impact point (EIP) may also be easily determined in the rare case of a golf club head having an asymmetric score line pattern, or no score lines at all. In such embodiments the engineered impact point (EIP) shall be determined in accordance with the USGA "Procedure for Measuring the Flexibility of a Golf Clubhead," Revision 2.0, Mar. 25, 2005, which is incorporated herein by reference. This USGA procedure identifies a process for determining the impact location on the face of a golf club that is to be tested, also referred therein as the face center. The USGA procedure utilizes a template that is placed on the face of the golf club to determine the face center. In these limited cases of asymmetric score line patterns, or no score lines at all, this USGA face center shall be the engineered impact point (EIP) that is referenced throughout this application.

The engineered impact point (EIP) on the face is an important reference to define other attributes of the present golf club head. The engineered impact point (EIP) is generally shown on the face with rotated crosshairs labeled EIP. The precise location of the engineered impact point (EIP) can be identified via the dimensions X_{eip}, Y_{eip}, and Z_{eip}, as illustrated in FIGS. 22-24. The X coordinate X_{eip} is measured in the same manner as X_{cg}, the Y coordinate Y_{eip} is measured in the same manner as Y_{cg}, and the Z coordinate Z_{eip} is measured in the same manner as Z_{cg}, except that Z_{eip} is always a positive value regardless of whether it is in front of the origin point or behind the origin point.

One important dimension that utilizes the engineered impact point (EIP) is the center face progression (CFP), seen in FIGS. 8 and 14. The center face progression (CFP) is a single dimension measurement and is defined as the distance in the Z-direction from the shaft axis (SA) to the engineered impact point (EIP). A second dimension that utilizes the engineered impact point (EIP) is referred to as a club moment arm (CMA). The CMA is the two dimensional distance from the CG of the club head to the engineered impact point (EIP) on the face, as seen in FIG. 8. Thus, with reference to the coordinate system shown in FIG. 1, the club moment arm (CMA) includes a component in the Z-direction and a component in the Y-direction, but ignores any difference in the X-direction between the CG and the engineered impact point (EIP). Thus, the club moment arm (CMA) can be thought of in terms of an impact vertical plane passing through the engineered impact point (EIP) and extending in the Z-direction. First, one would translate the CG horizontally in the X-direction until it hits the impact vertical plane. Then, the club moment arm (CMA) would be the distance from the projection of the CG on the impact vertical plane to the engineered impact point (EIP). The club moment arm (CMA) has a significant impact on the launch angle and the spin of the golf ball upon impact.

Another important dimension in golf club design is the club head blade length (BL), seen in FIG. 13 and FIG. 14. The blade length (BL) is the distance from the origin to a point on the surface of the club head on the toe side that is furthest from the origin in the X-direction. The blade length (BL) is composed of two sections, namely the heel blade length section (Abl) and the toe blade length section (Bbl). The point of delineation between these two sections is the engineered impact point (EIP), or more appropriately, a vertical line, referred to as a face centerline (FC), extending through the engineered impact point (EIP), as seen in FIG. 13, when the golf club head is in the normal resting position, also referred to as the design position.

Further, several additional dimensions are helpful in understanding the location of the CG with respect to other points that are essential in golf club engineering. First, a CG angle (CGA) is the one dimensional angle between a line connecting the CG to the origin and an extension of the shaft axis (SA), as seen in FIG. 14. The CG angle (CGA) is measured solely in the X-Z plane and therefore does not account for the elevation change between the CG and the origin, which is why it is easiest understood in reference to the top plan view of FIG. 14.

Lastly, another important dimension in quantifying the present golf club only takes into consideration two dimensions and is referred to as the transfer distance (TD), seen in FIG. 17. The transfer distance (TD) is the horizontal distance from the CG to a vertical line extending from the origin; thus, the transfer distance (TD) ignores the height of the CG, or Y_{cg}. Thus, using the Pythagorean Theorem from simple geometry, the transfer distance (TD) is the hypotenuse of a right triangle with a first leg being X_{cg} and the second leg being Z_{cg}.

The transfer distance (TD) is significant in that it helps define another moment of inertia value that is significant to the present golf club. This new moment of inertia value is defined as the face closing moment of inertia, referred to as MOI_{fc}, which is the horizontally translated (no change in Y-direction elevation) version of MOI_y around a vertical axis that passes through the origin. MOI_{fc} is calculated by adding MOI_y to the product of the club head mass and the transfer distance (TD) squared. Thus,

$$MOI_{fc} = MOI_y + (mass * (TD)^2)$$

The face closing moment (MOI_{fc}) is important because it represents the resistance that a golfer feels during a swing when trying to bring the club face back to a square position for impact with the golf ball. In other words, as the golf swing returns the golf club head to its original position to impact the golf ball the face begins closing with the goal of being square at impact with the golf ball.

The presently disclosed hollow golf club incorporates stress reducing features unlike prior hollow type golf clubs. The hollow type golf club includes a shaft (200) having a proximal end (210) and a distal end (220); a grip (300) attached to the shaft proximal end (210); and a golf club head (100) attached at the shaft distal end (220), as seen in FIG. 21. The overall hollow type golf club has a club length of at least 36 inches and no more than 48 inches, as measure in accordance with USGA guidelines.

The golf club head (400) itself is a hollow structure that includes a face (500) positioned at a front portion (402) of the golf club head (400) where the golf club head (400) impacts a golf ball, a sole (700) positioned at a bottom portion of the golf club head (400), a crown (600) positioned at a top portion of the golf club head (400), and a skirt (800) positioned around a portion of a periphery of the golf club head (400) between the sole (700) and the crown (800). The face (500), sole (700), crown (600), and skirt (800) define an outer shell that further defines a head volume that is less than 500 cubic centimeters for the golf club head (400). Additionally, the golf club head (400) has a rear portion (404) opposite the face (500). The rear portion (404) includes the trailing edge of the golf club head (400), as is understood by one with skill in the art. The face (500) has a loft (L) of at least 6 degrees, and the face (500) includes an engineered impact point (EIP) as defined above. One skilled in the art will appreciate that the skirt (800) may be significant at some areas of the golf club head (400) and virtually nonexistent at other areas; particularly at the rear portion (404) of the golf club head (400).

where it is not uncommon for it to appear that the crown (600) simply wraps around and becomes the sole (700).

The golf club head (100) includes a bore having a center that defines a shaft axis (SA) that intersects with a horizontal ground plane (GP) to define an origin point, as previously explained. The bore is located at a heel side (406) of the golf club head (400) and receives the shaft distal end (220) for attachment to the golf club head (400). The golf club head (100) also has a toe side (408) located opposite of the heel side (406). The presently disclosed golf club head (400) has a club head mass of less than 310 grams, which combined with the previously disclosed loft, club head volume, and club length establish that the presently disclosed golf club is directed to a hollow golf club such as a driver, fairway wood, hybrid, or hollow iron.

The golf club head (400) may include a stress reducing feature (1000) including a crown located SRF (1100) located on the crown (600), seen in FIG. 22, and/or a sole located SRF (1300) located on the sole (700), seen in FIG. 23, and/or a toe located SRF (1500) located at least partially on the skirt (800) on a toe portion of the club head (400), seen in FIG. 54, and/or a heel located SRF (1700) located at least partially on the skirt (800) on a heel portion of the club head (400), seen in FIG. 59. As seen in FIGS. 22 and 25, the crown located SRF (1100) has a CSRF length (1110) between a CSRF toe-most point (1112) and a CSRF heel-most point (1116), a CSRF leading edge (1120), a CSRF trailing edge (1130), a CSRF width (1140), and a CSRF depth (1150). Similarly, as seen in FIGS. 23 and 25, the sole located SRF (1300) has a SSRF length (1310) between a SSRF toe-most point (1312) and a SSRF heel-most point (1316), a SSRF leading edge (1320), a SSRF trailing edge (1330), a SSRF width (1340), and a SSRF depth (1350). Further, as seen in FIGS. 57 and 58, the toe located SRF (1500) has a TSRF length (1510) between a TSRF crown-most point (1512) and a TSRF sole-most point (1516), a TSRF leading edge (1520), a TSRF trailing edge (1530), a TSRF width (1540), and a TSRF depth (1550). Likewise, as seen in FIGS. 57 and 59, the heel located SRF (1700) has a HSRF length (1710) between a HSRF crown-most point (1712) and a HSRF sole-most point (1716), a HSRF leading edge (1720), a HSRF trailing edge (1730), a HSRF width (1740), and a HSRF depth (1750).

With reference now to FIG. 24, in embodiments which incorporate both a crown located SRF (1100) and a sole located SRF (1300), a SRF connection plane (2500) passes through a portion of the crown located SRF (1100) and the sole located SRF (1300). To locate the SRF connection plane (2500) a vertical section is taken through the club head (400) in a front-to-rear direction, perpendicular to a vertical plane created by the shaft axis (SA); such a section is seen in FIG. 24. Then a crown SRF midpoint of the crown located SRF (1100) is determined at a location on a crown imaginary line following the natural curvature of the crown (600). The crown imaginary line is illustrated in FIG. 24 with a broken, or hidden, line connecting the CSRF leading edge (1120) to the CSRF trailing edge (1130), and the crown SRF midpoint is illustrated with an X. Similarly, a sole SRF midpoint of the sole located SRF (1300) is determined at a location on a sole imaginary line following the natural curvature of the sole (700). The sole imaginary line is illustrated in FIG. 24 with a broken, or hidden, line connecting the SSRF leading edge (1320) to the SSRF trailing edge (1330), and the sole SRF midpoint is illustrated with an X. Finally, the SRF connection plane (2500) is a plane in the heel-to-toe direction that passes through both the crown SRF midpoint and the sole SRF midpoint, as seen in FIG. 24. While the SRF connection plane (2500) illustrated in FIG. 24 is approximately vertical, the

orientation of the SRF connection plane (2500) depends on the locations of the crown located SRF (1100) and the sole located SRF (1300) and may be angled toward the face, as seen in FIG. 26, or angled away from the face, as seen in FIG. 27.

The SRF connection plane (2500) is oriented at a connection plane angle (2510) from the vertical, seen in FIGS. 26 and 27, which aids in defining the location of the crown located SRF (1100) and the sole located SRF (1300). In one particular embodiment the crown located SRF (1100) and the sole located SRF (1300) are not located vertically directly above and below one another; rather, the connection plane angle (2510) is greater than zero and less than ninety percent of a loft (L) of the club head (400), as seen in FIG. 26. The sole located SRF (1300) could likewise be located in front of, i.e. toward the face (500), the crown located SRF (1100) and still satisfy the criteria of this embodiment; namely, that the connection plane angle (2510) is greater than zero and less than ninety percent of a loft of the club head (400).

In an alternative embodiment, seen in FIG. 27, the SRF connection plane (2500) is oriented at a connection plane angle (2510) from the vertical and the connection plane angle (2510) is at least ten percent greater than a loft (L) of the club head (400). The crown located SRF (1100) could likewise be located in front of, i.e. toward the face (500), the sole located SRF (1300) and still satisfy the criteria of this embodiment; namely, that the connection plane angle (2510) is at least ten percent greater than a loft (L) of the club head (400). In an even further embodiment the SRF connection plane (2500) is oriented at a connection plane angle (2510) from the vertical and the connection plane angle (2510) is at least fifty percent greater than a loft (L) of the club head (400), but less than one hundred percent greater than the loft (L). These three embodiments recognize a unique relationship between the crown located SRF (1100) and the sole located SRF (1300) such that they are not vertically aligned with one another, while also not merely offset in a manner matching the loft (L) of the club head (400).

With reference now to FIGS. 30 and 31, in the event that a crown located SRF (1100) or a sole located SRF (1300), or both, do not exist at the location of the CG section, labeled as section 24-24 in FIG. 22, then the crown located SRF (1100) located closest to the front-to-rear vertical plane passing through the CG is selected. For example, as seen in FIG. 30 the right crown located SRF (1100) is nearer to the front-to-rear vertical CG plane than the left crown located SRF (1100). In other words the illustrated distance "A" is smaller for the right crown located SRF (1100). Next, the face centerline (FC) is translated until it passes through both the CSRF leading edge (1120) and the CSRF trailing edge (1130), as illustrated by broken line "B". Then, the midpoint of line "B" is found and labeled "C". Finally, imaginary line "D" is created that is perpendicular to the "B" line.

The same process is repeated for the sole located SRF (1300), as seen in FIG. 31. It is simply a coincidence that both the crown located SRF (1100) and the sole located SRF (1300) located closest to the front-to-rear vertical CG plane are both on the heel side (406) of the golf club head (400). The same process applies even when the crown located SRF (1100) and the sole located SRF (1300) located closest to the front-to-rear vertical CG plane are on opposite sides of the golf club head (400). Now, still referring to FIG. 31, the process first involves identifying that the right sole located SRF (1300) is nearer to the front-to-rear vertical CG plane than the left sole located SRF (1300). In other words the illustrated distance "E" is smaller for the heel-side sole located SRF (1300). Next, the face centerline (FC) is trans-

lated until it passes through both the SSRF leading edge (1320) and the SSRF trailing edge (1330), as illustrated by broken line "F". Then, the midpoint of line "F" is found and labeled "G". Finally, imaginary line "H" is created that is perpendicular to the "F" line. The plane passing through both the imaginary line "D" and imaginary line "H" is the SRF connection plane (1500).

Next, referring back to FIG. 24, a CG-to-plane offset (2600) is defined as the shortest distance from the center of gravity (CG) to the SRF connection plane (1500), regardless of the location of the CG. In one particular embodiment the CG-to-plane offset (2600) is at least twenty-five percent less than the club moment arm (CMA) and the club moment arm (CMA) is less than 1.3 inches.

The locations of the crown located SRF (1100), the sole located SRF (1300), the toe located SRF (1500), and/or the heel located SRF (1700) described herein, and the associated variables identifying the location, are selected to preferably reduce the stress in the face (500) when impacting a golf ball while accommodating temporary flexing and deformation of the crown located SRF (1100), the sole located SRF (1300), the toe located SRF (1500), and/or the heel located SRF (1700) in a stable manner in relation to the CG location, and/or origin point, while maintaining the durability of the face (500), the crown (600), and the sole (700). Experimentation and modeling has shown that the crown located SRF (1100), the sole located SRF (1300), the toe located SRF (1500), and/or the heel located SRF (1700) may increase the deflection of the face (500), while also reduce the peak stress on the face (500) at impact with a golf ball. This reduction in stress allows a substantially thinner face to be utilized, permitting the weight savings to be distributed elsewhere in the club head (400). Further, the increased deflection of the face (500) facilitates improvements in the coefficient of restitution (COR) of the club head (400), as well as the distribution of the deflection across the face (500).

In fact, further embodiments even more precisely identify the location of the crown located SRF (1100), the sole located SRF (1300), the toe located SRF (1500), and/or the heel located SRF (1700) to achieve these objectives. For instance, in one further embodiment the CG-to-plane offset (2600) is at least twenty-five percent of the club moment arm (CMA) and less than seventy-five percent of the club moment arm (CMA). In still a further embodiment, the CG-to-plane offset (2600) is at least forty percent of the club moment arm (CMA) and less than sixty percent of the club moment arm (CMA).

Alternatively, another embodiment relates the location of the crown located SRF (1100) and/or the sole located SRF (1300) to the difference between the maximum top edge height (TEH) and the minimum lower edge (LEH), referred to as the face height, rather than utilizing the CG-to-plane offset (2600) variable as previously discussed to accommodate embodiments in which a single SRF is present. As such, two additional variables are illustrated in FIG. 24, namely the CSRF leading edge offset (1122) and the SSRF leading edge offset (1322). The CSRF leading edge offset (1122) is the distance from any point along the CSRF leading edge (1120) directly forward, in the Zcg direction, to the point at the top edge (510) of the face (500). Thus, the CSRF leading edge offset (1122) may vary along the length of the CSRF leading edge (1120), or it may be constant if the curvature of the CSRF leading edge (1120) matches the curvature of the top edge (510) of the face (500). Nonetheless, there will always be a minimum CSRF leading edge offset (1122) at the point along the CSRF leading edge (1120) that is the closest to the corresponding point directly in front of it on the face top edge (510), and there will be a maximum CSRF leading edge offset

(1122) at the point along the CSRF leading edge (1120) that is the farthest from the corresponding point directly in front of it on the face top edge (510). Likewise, the SSRF leading edge offset (1322) is the distance from any point along the SSRF leading edge (1320) directly forward, in the Zcg direction, to the point at the lower edge (520) of the face (500). Thus, the SSRF leading edge offset (1322) may vary along the length of the SSRF leading edge (1320), or it may be constant if the curvature of SSRF leading edge (1320) matches the curvature of the lower edge (520) of the face (500). Nonetheless, there will always be a minimum SSRF leading edge offset (1322) at the point along the SSRF leading edge (1320) that is the closest to the corresponding point directly in front of it on the face lower edge (520), and there will be a maximum SSRF leading edge offset (1322) at the point along the SSRF leading edge (1320) that is the farthest from the corresponding point directly in front of it on the face lower edge (520). Generally, the maximum CSRF leading edge offset (1122) and the maximum SSRF leading edge offset (1322) will be less than seventy-five percent of the face height. For the purposes of this application and ease of definition, the face top edge (510) is the series of points along the top of the face (500) at which the vertical face roll becomes less than one inch, and similarly the face lower edge (520) is the series of points along the bottom of the face (500) at which the vertical face roll becomes less than one inch.

In this particular embodiment, the minimum CSRF leading edge offset (1122) is less than the face height, while the minimum SSRF leading edge offset (1322) is at least two percent of the face height. In an even further embodiment, the maximum CSRF leading edge offset (1122) is also less than the face height. Yet another embodiment incorporates a minimum CSRF leading edge offset (1122) that is at least ten percent of the face height, and the minimum CSRF width (1140) is at least fifty percent of the minimum CSRF leading edge offset (1122). A still further embodiment more narrowly defines the minimum CSRF leading edge offset (1122) as being at least twenty percent of the face height.

Likewise, many embodiments are directed to advantageous relationships of the sole located SRF (1300). For instance, in one embodiment, the minimum SSRF leading edge offset (1322) is at least ten percent of the face height, and the minimum SSRF width (1340) is at least fifty percent of the minimum SSRF leading edge offset (1322). Even further, another embodiment more narrowly defines the minimum SSRF leading edge offset (1322) as being at least twenty percent of the face height.

Still further building upon the relationships among the CSRF leading edge offset (1122), the SSRF leading edge offset (1322), and the face height, one embodiment further includes an engineered impact point (EIP) having a Yeip coordinate such that the difference between Yeip and Ycg is less than 0.5 inches and greater than -0.5 inches; a Xeip coordinate such that the difference between Xeip and Xcg is less than 0.5 inches and greater than -0.5 inches; and a Zeip coordinate such that the total of Zeip and Zcg is less than 2.0 inches. These relationships among the location of the engineered impact point (EIP) and the location of the center of gravity (CG) in combination with the leading edge locations of the crown located SRF (1100) and/or the sole located SRF (1300) promote stability at impact, while accommodating desirable deflection of the SRFs (1100, 1300) and the face (500), while also maintaining the durability of the club head (400) and reducing the peak stress experienced in the face (500).

While the location of the crown located SRF (1100), the sole located SRF (1300), the toe located SRF (1500), and/or

13

the heel located SRF (1700) is important in achieving these objectives, the size of the crown located SRF (1100), the sole located SRF (1300), the toe located SRF (1500), and/or the heel located SRF (1700) also play a role. In one particular long blade length embodiment, illustrated in FIGS. 42 and 43, the golf club head (400) has a blade length (BL) of at least 3.0 inches with a heel blade length section (Abl) of at least 0.8 inches. In this embodiment, preferable results are obtained when the CSRFB length (1110) is at least as great as the heel blade length section (Abl) and the maximum CSRFB depth (1150) is at least ten percent of the Ycg distance, thereby permitting adequate compression and/or flexing of the crown located SRF (1100) to significantly reduce the stress on the face (500) at impact. Similarly, in some SSRFB embodiments, preferable results are obtained when the SSRFB length (1310) is at least as great as the heel blade length section (Abl) and the maximum SSRFB depth (1350) is at least ten percent of the Ycg distance, thereby permitting adequate compression and/or flexing of the sole located SRF (1300) to significantly reduce the stress on the face (500) at impact. It should be noted at this point that the cross-sectional profile of the crown located SRF (1100), the sole mounted SRF (1300), the toe located SRF (1500), and/or the heel located SRF (1700) may include any number of shapes including, but not limited to, a box-shape, as seen in FIG. 24, a smooth U-shape, as seen in FIG. 28, and a V-shape, as seen in FIG. 29. Further, the crown located SRF (1100), the sole located SRF (1300), the toe located SRF (1500), and/or the heel located SRF (1700) may include reinforcement areas as seen in FIGS. 40 and 41 to further selectively control the deformation of the SRFs (1100, 1300, 1500, 1700). Additionally, the CSRFB length (1110) and the SSRFB length (1310) are measured in the same direction as Xcg rather than along the curvature of the SRFs (1100, 1300), if curved.

In yet another embodiment, preferable results are obtained when a maximum TSRFB depth (1550) is greater than a maximum HSRFB depth (1750), as seen in FIGS. 57 and 72. In fact, in one particular embodiment the maximum TSRFB depth (1550) is at least twice the maximum HSRFB depth (1750). A further embodiment incorporates a maximum TSRFB width (1540) and a maximum HSRFB width (1740) that are at least ten percent of the Zcg distance, in combination with a maximum TSRFB depth (1550) and a maximum HSRFB depth (1750) that are at least ten percent of the Ycg distance. An even further embodiment has a maximum TSRFB depth (1550) that is at least twenty percent of the Ycg distance, and/or a maximum HSRFB depth (1750) that is less than twenty percent of the Ycg distance. Another embodiment incorporates a TSRFB length (1510) that is greater than HSRFB length (1710). These depth, widths, lengths, and associated relationships facilitate adequate and stable compression and/or flexing of the toe located SRF (1500) and/or heel located SRF (1700) to significantly reduce the stress on the face (500) at impact, while accounting for the typical impact dispersion across the face of low-heel to high-toe impacts, swing paths associated with the typical impact dispersion, and inherent changes in club head stiffness and rigidity from the heel portion to the toe portion. In yet another embodiment, preferable deflection and durability results are obtained when a maximum TSRFB depth (1550) is greater than a maximum TSRFB width (1540), as seen in FIGS. 71 and 74. In fact, in one particular embodiment the maximum TSRFB depth (1550) is at least twice the maximum TSRFB width (1540).

The crown located SRF (1100) has a CSRFB wall thickness (1160), the sole located SRF (1300) has a SSRFB wall thickness (1360), the toe located SRF (1500) has a TSRFB wall thickness (1565), and the heel located SRF (1700) has a

14

HSRFB wall thickness (1765), as seen in FIG. 25 and FIG. 57. In most embodiments the CSRFB wall thickness (1160), the SSRFB wall thickness (1360), TSRFB wall thickness (1565), and the HSRFB wall thickness (1765) will be at least 0.010 inches and no more than 0.150 inches. In particular embodiment has found that having the maximum CSRFB wall thickness (1160), the maximum SSRFB wall thickness (1360), the maximum TSRFB wall thickness (1565), and the maximum HSRFB wall thickness (1765) in the range of ten percent to sixty percent of the face thickness (530) achieves the required durability while still providing desired stress reduction in the face (500) and deflection of the face (500). Further, this range facilitates the objectives while not have a dilutive effect, nor overly increasing the weight distribution of the club head (400) in the vicinity of the SRF's (1100, 1300, 1500, 1700).

Further, the terms maximum CSRFB depth (1150), maximum SSRFB depth (1350), maximum TSRFB depth (1550), and maximum HSRFB depth (1750) are used because the depth of the crown located SRF (1100), the depth of the sole located SRF (1300), the depth of the toe located SRF (1500), and the depth of the heel located SRF (1700) need not be constant; in fact, they are likely to vary, as seen in FIGS. 32-35, and 72-78. Additionally, the end walls of the crown located SRF (1100), the sole located SRF (1300), the toe located SRF (1500), and the heel located SRF (1700) need not be distinct, as seen on the right and left side of the SRFs (1100, 1300) seen in FIG. 35, but may transition from the maximum depth back to the natural contour of the crown (600), sole (700), and/or skirt (800). The transition need not be smooth, but rather may be stepwise, compound, or any other geometry. In fact, the presence or absence of end walls is not necessary in determining the bounds of the claimed golf club. Nonetheless, a criteria needs to be established for identifying the location of the CSRFB toe-most point (1112), the CSRFB heel-most point (1116), the SSRFB toe-most point (1312), the SSRFB heel-most point (1316), the TSRFB crown-most point (1512), the TSRFB sole-most point (1516), the HSRFB crown-most point (1712), and the HSRFB sole-most point (1716); thus, when not identifiable via distinct end walls, these points occur where a deviation from the natural curvature of the crown (600), sole (700), or skirt (800) is at least ten percent of the maximum CSRFB depth (1150), maximum SSRFB depth (1350), maximum TSRFB depth (1550), or maximum HSRFB depth (1750). In most embodiments a maximum CSRFB depth (1150), a maximum SSRFB depth (1350), a maximum TSRFB depth (1550), and a maximum HSRFB depth (1750) of at least 0.100 inches and no more than 0.750 inches is preferred. The overall stress distribution in the club head, the face, and the stress reducing feature (1000) at impact with a golf ball are heavily influenced by the face thickness (530) and the depth of the stress reducing feature (1150, 1350, 1550, 1750). In one embodiment sufficient deflection is achieved without sacrificing durability when the minimum CSRFB depth (1150), the minimum SSRFB depth (1350), the minimum TSRFB depth (1550), and/or the minimum HSRFB depth (1750) is greater than the maximum face thickness (530).

The CSRFB leading edge (1120) may be straight or may include a CSRFB leading edge radius of curvature (1124), as seen in FIG. 36. Likewise, the SSRFB leading edge (1320) may be straight or may include a SSRFB leading edge radius of curvature (1324), as seen in FIG. 37. One particular embodiment incorporates both a curved CSRFB leading edge (1120) and a curved SSRFB leading edge (1320) wherein both the CSRFB leading edge radius of curvature (1124) and the SSRFB leading edge radius of curvature (1324) are within forty percent of the curvature of the bulge of the face (500). In an even further embodiment both the CSRFB leading edge radius of

curvature (1124) and the SSRF leading edge radius of curvature (1324) are within twenty percent of the curvature of the bulge of the face (500). These curvatures further aid in the controlled deflection of the face (500).

One particular embodiment, illustrated in FIGS. 32-35, has a CSRf depth (1150) that is less at the face centerline (FC) than at a point on the toe side (408) of the face centerline (FC) and at a point on the heel side (406) of the face centerline (FC), thereby increasing the potential deflection of the face (500) at the heel side (406) and the toe side (408), where the COR is generally lower than the USGA permitted limit. One toe located SRF (1500) embodiment, seen in FIG. 72, has at least a portion of the toe located SRF (1500) above the elevation of the center of gravity (CG) with a TSRf depth (1550) is greater than a portion of the toe located SRF (1500) below the elevation of the center of gravity (CG), while other embodiments have a TSRf depth (1550) that generally increases as the elevation from the ground plane increases. In yet another embodiment, preferable results are obtained when a maximum TSRf depth (1550) is greater than a maximum HSRf depth (1750), as seen in FIGS. 57 and 72. In fact, in one particular embodiment the maximum TSRf depth (1550) is at least twice the maximum HSRf depth (1750), thereby increasing the potential deflection of the face (500) at the upper toe side of the face, an impact location of many amateur golfers. In another embodiment, the crown located SRF (1100) and/or the sole located SRF (1300) have reduced depth regions, namely a CSRf reduced depth region (1152) and a SSRf reduced depth region (1352), as seen in FIG. 35. Each reduced depth region is characterized as a continuous region having a depth that is at least twenty percent less than the maximum depth for the particular SRF (1100, 1300). The CSRf reduced depth region (1152) has a CSRf reduced depth length (1154) and the SSRf reduced depth region (1352) has a SSRf reduced depth length (1354). Such reduced depth regions may also be incorporated into the disclosed toe located SRF (1500) and/or the heel located SRF (1700). In one particular embodiment, each reduced depth length (1154, 1354) is at least fifty percent of the heel blade length section (Abl). A further embodiment has the CSRf reduced depth region (1152) and the SSRf reduced depth region (1352) approximately centered about the face centerline (FC), as seen in FIG. 35. Yet another embodiment incorporates a design wherein the CSRf reduced depth length (1154) is at least thirty percent of the CSRf length (1110), and/or the SSRf reduced depth length (1354) is at least thirty percent of the SSRf length (1310). In addition to aiding in achieving the objectives set out above, the reduced depth regions (1152, 1352) may improve the life of the SRFs (1100, 1300) and reduce the likelihood of premature failure, while increasing the COR at desirable locations on the face (500).

As seen in FIGS. 25, 74, and 78, the crown located SRF (1100) has a CSRf cross-sectional area (1170), the sole located SRF (1300) has a SSRf cross-sectional area (1370), the toe located SRF (1500) has a TSRf cross-sectional area (1570), and the heel located SRF (1700) has a HSRf cross-sectional area (1770). The cross-sectional areas are measured in cross-sections that run from the front portion (402) to the rear portion (404) of the club head (400) in a vertical plane. Just as the cross-sectional profiles (1190, 1390) of FIGS. 28 and 29 may change throughout the CSRf length (1110), the SSRf length (1310), the TSRf length (1510), and the HSRf length (1710), the CSRf cross-sectional area (1170), the SSRf cross-sectional area (1370), the TSRf cross-sectional area (1570), and/or the HSRf cross-sectional area (1770) may also vary along the lengths (1110, 1310, 1510, 1710). In fact, in one particular embodiment, the CSRf cross-sectional

area (1170) is less at the face centerline (FC) than at a point on the toe side (408) of the face centerline (FC) and a point on the heel side (406) of the face centerline (FC). Similarly, in another embodiment, the SSRf cross-sectional area (1370) is less at the face centerline than at a point on the toe side (408) of the face centerline (FC) and a point on the heel side (406) of the face centerline (FC); and yet a third embodiment incorporates both of the prior two embodiments related to the CSRf cross-sectional area (1170) and the SSRf cross-sectional area (1370).

One particular embodiment promotes preferred face deflection, stability, and durability with at least one TSRf cross-sectional area (1570) taken at an elevation greater than the Ycg distance that is greater than at least one TSRf cross-sectional area (1570) taken at an elevation below the Ycg distance, as seen in FIG. 72. The change in TSRf cross-sectional area (1570) may be achieved in part by having a maximum TSRf depth (1550) at an elevation greater than the Ycg distance that is at least fifty percent greater than the maximum TSRf depth (1550) taken at an elevation below the Ycg distance.

The length of the stress reducing feature (1000) also plays a significant role in achieving the stated goals. In one particular embodiment, the length of any of the CSRf length (1110), the SSRf length (1310), the TSRf length (1510), and/or the HSRf length (1710) is greater than the Xcg distance, the Ycg distance, and the Zcg distance. In a further embodiment, either, or both, the TSRf length (1510) and/or the HSRf length (1710) is also less than twice the Ycg distance. Likewise, in a further embodiment, either, or both, the CSRf length (1110) and/or the SSRf length (1310) is also less than three times the Xcg distance. The length of the stress reducing feature (1000) is also tied to the width of the stress reducing feature (1000) to achieve the desired improvements. For instance, in one embodiment the TSRf length (1510) is at least seven times the maximum TSRf width (1540), and the same may be true in additional embodiments directed to the crown located SRF (1100), the sole located SRF (1300), and the heel located SRF (1700).

Further, in another embodiment, the TSRf cross-sectional area (1570) is less at the TSRf sole-most point (1516) than at a TSRf crown-most point (1512), in fact in one embodiment the TSRf cross-sectional area (1570) at the TSRf crown-most point (1512) is at least double the TSRf cross-sectional area (1570) at the TSRf sole-most point (1516). Conversely, in another embodiment, the HSRf cross-sectional area (1770) is greater at the HSRf sole-most point (1716) than at the HSRf crown-most point (1712), in fact in one embodiment the HSRf cross-sectional area (1770) at the HSRf sole-most point (1716) is at least double the HSRf cross-sectional area (1770) at the HSRf crown-most point (1712).

In one particular embodiment, the CSRf cross-sectional area (1170), the SSRf cross-sectional area (1370), the TSRf cross-sectional area (1570), and/or the HSRf cross-sectional area (1770) fall within the range of 0.005 square inches to 0.375 square inches. Additionally, the crown located SRF (1100) has a CSRf volume, the sole located SRF (1300) has a SSRf volume, the toe located SRF (1500) has a TSRf volume, and the heel located SRF (1700) has a HSRf volume. In one embodiment the combined CSRf volume and SSRf volume is at least 0.5 percent of the club head volume and less than 10 percent of the club head volume, as this range facilitates the objectives while not have a dilutive effect, nor overly increasing the weight distribution of the club head (400) in the vicinity of the SRFs (1100, 1300). In another embodiment the combined TSRf volume and HSRf volume is at least 0.5

percent of the club head volume and less than 10 percent of the club head volume, as this range facilitates the objectives while not have a dilutive effect, nor overly increasing the weight distribution of the club head (400) in the vicinity of the SRFs (1500, 1700). In yet another embodiment directed to single SRF variations, the individual volume of the CSRFF volume, the SSRFF volume, the TSRFF volume, or the HSRFF volume is preferably at least 0.5 percent of the club head volume and less than 5 percent of the club head volume to facilitate the objectives while not have a dilutive effect, nor overly increasing the weight distribution of the club head (400) in the vicinity of the SRFs (1100, 1300, 1500, 1700). The volumes discussed above are not meant to limit the SRFs (1100, 1300, 1500, 1700) to being hollow channels, for instance the volumes discussed will still exist even if the SRFs (1100, 1300, 1500, 1700) are subsequently filled with a secondary material, as seen in FIG. 51, or covered, such that the volume is not visible to a golfer. The secondary material should be elastic, have a compressive strength less than half of the compressive strength of the outer shell, and a density less than 3 g/cm³.

Now, in another separate embodiment seen in FIGS. 36 and 37, a CSRFF origin offset (1118) is defined as the distance from the origin point to the CSRFF heel-most point (1116) in the same direction as the Xcg distance such that the CSRFF origin offset (1118) is a positive value when the CSRFF heel-most point (1116) is located toward the toe side (408) of the golf club head (400) from the origin point, and the CSRFF origin offset (1118) is a negative value when the CSRFF heel-most point (1116) is located toward the heel side (406) of the golf club head (400) from the origin point. Similarly, in this embodiment, a SSRFF origin offset (1318) is defined as the distance from the origin point to the SSRFF heel-most point (1316) in the same direction as the Xcg distance such that the SSRFF origin offset (1318) is a positive value when the SSRFF heel-most point (1316) is located toward the toe side (408) of the golf club head (400) from the origin point, and the SSRFF origin offset (1318) is a negative value when the SSRFF heel-most point (1316) is located toward the heel side (406) of the golf club head (400) from the origin point.

In one particular embodiment, seen in FIG. 37, the SSRFF origin offset (1318) is a positive value, meaning that the SSRFF heel-most point (1316) stops short of the origin point. Further, yet another separate embodiment is created by combining the embodiment illustrated in FIG. 36 wherein the CSRFF origin offset (1118) is a negative value, in other words the CSRFF heel-most point (1116) extends past the origin point, and the magnitude of the CSRFF origin offset (1118) is at least five percent of the heel blade length section (Abl). However, an alternative embodiment incorporates a CSRFF heel-most point (1116) that does not extend past the origin point and therefore the CSRFF origin offset (1118) is a positive value with a magnitude of at least five percent of the heel blade length section (Abl). In these particular embodiments, locating the CSRFF heel-most point (1116) and the SSRFF heel-most point (1316) such that they are no closer to the origin point than five percent of the heel blade length section (Abl) is desirable in achieving many of the objectives discussed herein over a wide range of ball impact locations.

Still further embodiments incorporate specific ranges of locations of the CSRFF toe-most point (1112) and the SSRFF toe-most point (1312) by defining a CSRFF toe offset (1114) and a SSRFF toe offset (1314), as seen in FIGS. 36 and 37. The CSRFF toe offset (1114) is the distance measured in the same direction as the Xcg distance from the CSRFF toe-most point (1112) to the most distant point on the toe side (408) of golf club head (400) in this direction, and likewise the SSRFF toe

offset (1314) is the distance measured in the same direction as the Xcg distance from the SSRFF toe-most point (1312) to the most distant point on the toe side (408) of golf club head (400) in this direction. One particular embodiment found to produce preferred face stress distribution and compression and flexing of the crown located SRF (1100) and the sole located SRF (1300) incorporates a CSRFF toe offset (1114) that is at least fifty percent of the heel blade length section (Abl) and a SSRFF toe offset (1314) that is at least fifty percent of the heel blade length section (Abl). In yet a further embodiment the CSRFF toe offset (1114) and the SSRFF toe offset (1314) are each at least fifty percent of a golf ball diameter; thus, the CSRFF toe offset (1114) and the SSRFF toe offset (1314) are each at 0.84 inches. These embodiments also minimally affect the integrity of the club head (400) as a whole, thereby ensuring the desired durability, particularly at the heel side (406) and the toe side (408) while still allowing for improved face deflection during off center impacts.

Even more embodiments now turn the focus to the size of the crown located SRF (1100), the sole located SRF (1300), the toe located SRF (1500), and/or the heel located SRF (1700). One such embodiment has a maximum CSRFF width (1140) that is at least ten percent of the Zcg distance, the maximum SSRFF width (1340) is at least ten percent of the Zcg distance, the maximum TSRFF width (1540) is at least ten percent of the Zcg distance, and/or the maximum HSRFF width (1740) is at least ten percent of the Zcg distance, further contributing to increased stability of the club head (400) at impact. Still further embodiments increase the maximum CSRFF width (1140), the maximum SSRFF width (1340), the maximum TSRFF width (1540), and/or the maximum HSRFF width (1740) such that they are each at least forty percent of the Zcg distance, thereby promoting deflection and selectively controlling the peak stresses seen on the face (500) at impact. An alternative embodiment relates the maximum CSRFF depth (1150), the maximum SSRFF depth (1350), the maximum TSRFF depth (1550), and/or the maximum HSRFF depth (1750) to the face height rather than the Zcg distance as discussed above. For instance, yet another embodiment incorporates a maximum CSRFF depth (1150), maximum SSRFF depth (1350), maximum TSRFF depth (1550), and/or maximum HSRFF depth (1750) that is at least five percent of the face height. An even further embodiment incorporates a maximum CSRFF depth (1150), maximum SSRFF depth (1350), maximum TSRFF depth (1550), and/or maximum HSRFF depth (1750) that is at least twenty percent of the face height, again, promoting deflection and selectively controlling the peak stresses seen on the face (500) at impact. In most embodiments a maximum CSRFF width (1140), a maximum SSRFF width (1340), a maximum TSRFF width (1540), and/or a maximum HSRFF width (1740) of at least 0.050 inches and no more than 0.750 inches is preferred.

Additional embodiments focus on the location of the crown located SRF (1100), the sole located SRF (1300), the toe located SRF (1500), and/or the heel located SRF (1700) with respect to a vertical plane defined by the shaft axis (SA), often referred to as the shaft axis plane (SAP), and the Xcg direction. One such embodiment has recognized improved stability and lower peak face stress when the crown located SRF (1100) is located behind the shaft axis plane. Further embodiments additionally define this relationship. Another embodiment has recognized improved stability and lower peak face stress when the sole located SRF (1300) is located in front of the shaft axis plane. In one such embodiment, the CSRFF leading edge (1120) is located behind the shaft axis plane a distance that is at least twenty percent of the Zcg distance. Yet another embodiment focuses on the location of the sole located

SRF (1300) such that the SSRF leading edge (1320) is located in front of the shaft axis plane a distance that is at least ten percent of the Zcg distance. An even further embodiment focusing on the crown located SRF (1100) incorporates a CSRf leading edge (1120) that is located behind the shaft axis plane a distance that is at least seventy-five percent of the Zcg distance. Another embodiment is directed to the sole located SRF (1300) has a forward-most point of the SSRF leading edge (1320) that is located in front of the shaft axis plane a distance of at least ten percent of the Zcg distance. Similarly, the locations of the CSRf leading edge (1120) and SSRF leading edge (1320) on opposite sides of the shaft axis plane may also be related to the face height instead of the Zcg distance discussed above. For instance, in one embodiment, the CSRf leading edge (1120) is located a distance behind the shaft axis plane that is at least ten percent of the face height. A further embodiment focuses on the location of the sole located SRF (1300) such that the forward-most point of the SSRF leading edge (1320) is located in front of the shaft axis plane a distance that is at least five percent of the face height. An even further embodiment focusing on both the crown located SRF (1100) and the sole located SRF (1300) incorporates a CSRf leading edge (1120) that is located behind the shaft axis plane a distance that is at least twenty percent of the face height, and a forward-most point on the SSRF leading edge (1320) that is located in front of behind the shaft axis plane a distance that is at least twenty percent of the face height.

Even further embodiments more precisely identify the location of the toe located SRF (1500) and/or the heel located SRF (1700) to achieve the stated objectives. For instance, in one embodiment the shaft axis plane (SAP), defined as a vertical plane passing through the shaft axis (SA) and illustrated in FIGS. 65-66, passes through a portion of toe located SRF (1500), the heel located SRF (1700), or both. In one particular embodiment at least twenty percent of the volume of the toe located SRF (1500) is in front of the shaft axis plane (SAP) and at least twenty percent of the volume of the toe located SRF (1500) is behind the shaft axis plane (SAP). In a similar embodiment directed to the heel located SRF (1700) at least twenty percent of the volume of the heel located SRF (1700) is in front of the shaft axis plane (SAP) and at least twenty percent of the volume of the heel located SRF (1700) is behind the shaft axis plane (SAP). One skilled in the art will know how to determine such volumes by submerging at least a portion of the club head in a liquid, and then doing the same with the SRF (1500, 1700) filled-in or covered with a piece of tape, or by filling the SRF (1100, 1300, 1500, 1700) with clay or other malleable material to achieve a smooth exterior profile of the club head and then removing and measuring the volume of the malleable material. In another embodiment, seen in FIG. 68, the toe located SRF (1500), the heel located SRF (1700), or both, are located entirely in front of the shaft axis (SA), and thus the shaft axis plane (SAP). Such embodiments encourage stable and controlled flexing of the toe located SRF (1500) and/or the heel located SRF (1700) with respect to the shaft axis (SA) when impacting a golf ball.

Another embodiment further defining the position locates the entire toe located SRF (1500) and/or the heel located SRF (1700) within a HT offset range distance, measured from the shaft axis (SA) in the front-to-back direction of Zcg seen in FIG. 56, that is less than twenty-five percent of the club moment arm (CMA). Thus, in this particular embodiment the TSRf leading edge (1520) and the TSRf trailing edge (1530), throughout the entire length of the toe located SRF (1500) are within the HT offset range distance of less than twenty-five percent of the club moment arm (CMA). Likewise, in this

particular embodiment the HSRf leading edge (1720) and the HSRf trailing edge (1730), throughout the entire length of the heel located SRF (1700) are within the HT offset range distance of less than twenty-five percent of the club moment arm (CMA). One particular embodiment incorporates both a toe located SRF (1500) and a heel located SRF (1700), wherein the forward-most point on the HSRf leading edge (1720) is closer to the face (500) than the forward-most point of the TSRf leading edge (1520). In this embodiment the asymmetric spacing from the face (500) of the toe located SRF (1500) and the heel located SRF (1700) allows for a preferred deflection variation across the face (500) while accounting for space constraints within the club head (400) with respect to the HSRf depth (1750) and the TSRf depth (1550).

The embodiment of FIG. 56 incorporates both a toe located SRF (1500) and a heel located SRF (1700), wherein the forward-most point on the TSRf leading edge (1520) is closer to the face (500) than the forward-most point of the HSRf leading edge (1720). In this embodiment the asymmetric spacing from the face (500) of the toe located SRF (1500) and the heel located SRF (1700) allows for a preferred deflection variation across the face (500) while accounting for constraints within the club head (400) with respect to how far the HSRf sole-most point (1716) and the TSRf sole-most point (1516) may extend toward the ground plane, as seen in FIG. 57, while maintaining a consistent appearance.

To even further identify the location of the toe located SRF (1500) and/or the heel located SRF (1700) to achieve the stated objectives it is necessary to discuss the elevation of the toe located SRF (1500) and the heel located SRF (1700). As previously noted and seen in FIG. 57, the toe located SRF (1500) has a TSRf crown-most point (1512), with an associated TSRf crown-most point elevation (1514), and a TSRf sole-most point (1516), with an associated TSRf sole-most point elevation (1518). Similarly, the heel located SRF (1700) has a HSRf crown-most point (1712), with an associated HSRf crown-most point elevation (1714), and a HSRf sole-most point (1716), with an associated HSRf sole-most point elevation (1718). In an effort to promote stability and preferred deflection at impact, the TSRf crown-most point (1512) has a TSRf crown-most point elevation (1514) greater than the Ycg distance and the Yeip distance, while extending downward such that the TSRf sole-most point (1516) has a TSRf sole-most point elevation (1518) less than the Ycg distance and the Yeip distance. Further, the HSRf sole-most point (1716) has a HSRf sole-most point elevation (1718) less than the Ycg distance and the Yeip distance. Yet another embodiment also incorporates a HSRf crown-most point (1712) having a HSRf crown-most point elevation (1714) greater than the Ycg distance. An even further embodiment also has the HSRf crown-most point (1712) below the EIP such that the HSRf crown-most point elevation (1714) is less than the Yeip distance. In this embodiment, the driver embodiment has a Ycg distance of 1.0"-1.4" and an EIP height of 1.1"-1.3", while fairway wood and hybrid iron embodiments have a Ycg distance of 0.4"-0.8" and EIP height of 0.6"-0.9".

A further embodiment has the TSRf crown-most point (1512) with a TSRf crown-most point elevation (1514) that is at least 25% greater than the Ycg distance, while extending downward such that the TSRf sole-most point (1516) has a TSRf sole-most point elevation (1518) that is at least 25% less than the Ycg distance. Further, the HSRf sole-most point (1716) has a HSRf sole-most point elevation (1718) that is at least 50% less than the Ycg distance. In one particular embodiment the HSRf sole-most point elevation (1718) is less than minimum elevation of the lower edge (520) of the face (500). Such embodiments promote stability and pre-

ferred face deflection across a wide range of impact locations common to the amateur golfer. Yet another embodiment also incorporates a HSRF crown-most point (1712) having a HSRF crown-most point elevation (1714) that is at least 25% greater than the Ycg distance.

One further embodiment incorporating both a toe located SRF (1500) and a heel located SRF (1700) incorporates a design preferably recognizing the typical impact dispersion across the face of low-heel to high-toe impacts and has a TSRF crown-most point (1512) with a TSRF crown-most point elevation (1514) that is greater than the HSRF crown-most point elevation (1714). In one particular embodiment the TSRF crown-most point (1512) and the HSRF crown-most point (1712) are located below the top edge height (TEH) of the face (500) so they are not visible in a top plan view as seen in FIG. 55, as some golfers prefer a clean top surface. Even further, additional embodiments locate the HSRF crown-most point (1712) such that it is hidden by the hosel and/or shaft as viewed by a golfer addressing a golf ball, as seen in FIGS. 56, 59, 68, and 70.

Further embodiments incorporate a club head (400) having a shaft connection system socket (2000) extending from the bottom portion of the golf club head (400) into the interior of the outer shell toward the top portion of the club head (400), as seen in FIGS. 68-78. The shaft connection system socket (2000) is the point at which a retainer is partially passed into the club head (400) to engage and retain a shaft or shaft connector. The shaft connection system socket (2000) is a location in which deformation of the club head (400) is undesirable, but may be used to facilitate and control the desired of the heel located SRF (1700). The shaft connection system socket (2000) may include a socket toe wall (2002), a socket fore-wall (2004), and/or a socket aft-wall (2006), as seen in FIG. 71. In this embodiment a portion of the shaft connection system socket (2000) connects to the heel located SRF (1700) at an interface referred to as a socket-to-HSRF junction (2030), seen best in the sections FIGS. 76-78 taken along section lines seen in FIG. 71. In this embodiment the heel located SRF (1700) does not have a distinct rear wall at the socket-to-HSRF junction (2030) and the a socket fore-wall (2004) supports a portion of the heel located SRF (1700) and serves to stabilize the heel located SRF (1700) while permitting deflection of the heel located SRF (1700). Similarly, the socket-to-HSRF junction (2030) may be along the socket aft-wall (2006) or the socket toe wall (2002). Such embodiments allow the shaft connection system socket (2000) and the heel located SRF (1700) to coexist in a relatively tight area on the club head (400) while providing a stable connection and preferential deformation of the heel located SRF (1700).

Another shaft connection system socket (2000) embodiment has a socket crown-most point (2010), seen best in FIG. 72, at an elevation less than the elevation of the HSRF crown-most point (1712). In this embodiment the heel located SRF (1700) extends above the shaft connection system socket (2000) to achieve the desired movement of the face (500) at impact with a golf ball. In the illustrated embodiment the socket-to-HSRF junction (2030) has a lineal junction length (2035), seen in FIG. 72, that is at least twenty-five percent of the HSRF length (1710), thereby allowing reduced HSRF width (1740) and/or HSRF depth (1750). In a further embodiment capitalizing on these attributes the socket-to-HSRF junction (2030) has a lineal junction length (2035), seen in FIG. 72, that is at least fifty percent of the HSRF length (1710).

One particularly durable embodiment providing a stable shaft connection system socket (2000) and a compliant heel located SRF (1700) includes a socket wall thickness (2020),

seen in FIG. 76, that has a minimum socket wall thickness (2020) that is at least fifty percent greater than a minimum HSRF wall thickness (1765), seen in FIG. 57. The shaft connection system socket (2000) has a socket depth (2040), as seen in FIGS. 76-78. The socket depth (2040) is easily measure by filling the shaft connection system socket (2000) with clay until the club head (400) has a smooth continuous exterior surface as if the socket (2000) does not exist. A blade oriented in the front-to-back direction, namely the direction Zcg is measured, may then be inserted vertically, namely in the direction Ycg is measured, to section the clay. The clay may then be removed and the vertical thickness measure to reveal the socket depth (2040), as illustrated in FIGS. 76-78. The process may be repeated at any point in the heel-to-toe direction, namely the direction that Xcg is measured, to determine a profile of the socket depth (2040).

As one with skill in the art will appreciate, this same process may be used to determine the CSRf depth (1150), the SSRf depth (1350), the TSRf depth (1540), HSRf depth (1740), the CSRf cross-sectional area (1170), the SSRf cross-sectional area (1370), the TSRf cross-sectional area (1570), or the HSRf cross-sectional area (1770). One particular embodiment incorporates a maximum socket depth (2040) that is at least twice the maximum HSRf depth (1750). Such an embodiment ensures a stable shaft connection system socket (2000) and a compliant heel located SRF (1700).

The added mass associated with the shaft connection system socket (2000) on the heel side (406) of the club head (400) helps offset the additional mass associated with the toe located SRF (1500) on the toe side (408) of the club head (400) and keeps the center of gravity (CG) from migrating too much toward either side or too high. Accordingly, the shaft connection system socket (2000) has a socket crown-most point (2010) at an elevation less than the elevation of the TSRf crown-most point (1512). Further, in one embodiment the socket crown-most point (2010) is at an elevation greater than the elevation of the TSRf sole-most point (1516). Still further, in another embodiment the socket crown-most point (2010) is at an elevation less than the Yeip distance.

Additionally, the volume and wall thicknesses of the stress reducing feature (1000) and the shaft connection system socket (2000) directly influence the acoustic properties of the club head (400). In one embodiment the shaft connection system socket (2000) has a socket volume, the toe located SRF (1500) has a TSRf volume, and the socket volume is less than the TSRf volume. In a further embodiment preferred results are achieved with a minimum socket wall thickness (2020) that is at least fifty percent greater than a minimum TSRf wall thickness (1565). Further, another embodiment achieves preferred acoustical properties with a maximum socket depth (2040) that is greater than the maximum TSRf depth (1550).

One particular embodiment includes a sole located SRF (1300) connecting the toe located SRF (1500) and the heel located SRF (1700), as seen in FIG. 68. All of the disclosure with respect to the sole located SRF (1300) of FIGS. 1-53 is applicable to the sole located SRF (1300) of FIGS. 68-75. In this embodiment the sole located SRF (1300) has a SSRf length (1310) between a SSRf toe-most point (1312) and a SSRf heel-most point (1316), a SSRf leading edge (1320) having a SSRf leading edge offset (1322), a SSRf width (1340), and a SSRf depth (1350), wherein the maximum SSRf width (1340) is at least ten percent of the Zcg distance. In this embodiment the sole located SRF (1300) may be entirely separate and distinct from the toe located SRF (1500) and/or the heel located SRF (1700), or the sole located SRF (1300) may be connected to either, or both, of the toe located

SRF (1500) and/or the heel located SRF (1700). One such embodiment, illustrated in FIGS. 68-75, incorporates a toe located SRF (1500) and a heel located SRF (1700) connected by a sole located SRF (1300). Another embodiment achieves preferred face deflection by incorporating a maximum TSRF depth (1550) at least twice the maximum HSRF depth (1750), and the maximum TSRF depth (1550) at least twice the maximum SSRF depth (1550). Further, such variable depth allows another embodiment to have a TSRF width (1540) that is substantially equal to the HSRF width (1740) and the SSRF width (1340). In these embodiments the delineation of the sole located SRF (1300) from the toe located SRF (1500) and/or the heel located SRF (1700) becomes difficult, therefore for these embodiments the sole located SRF (1300) is the portion within three-quarters of an inch from the face center (FC) toward the toe and within three-quarters of an inch from the face center (FC) toward the heel.

One skilled in the art will appreciate that all of the prior disclosure with respect to the CSRf aperture (1200) of the crown located SRF (1100) and the SSRf aperture (1400) of the sole located SRF (1300) applies equally to the toe located SRF (1500) and the heel located SRF (1700) but will not be repeated here to avoid excessive repetition. Thus, the toe located SRF (1500) may incorporate a TSRf aperture and the heel located SRF (1700) may incorporate a HSRf aperture.

The club head (400) is not limited to a single crown located SRF (1100) and/or a single sole located SRF (1300). In fact, many embodiments incorporating multiple crown located SRFs (1100) and/or multiple sole located SRFs (1300) are illustrated in FIGS. 30, 31, and 39, showing that the multiple SRFs (1100, 1300) may be positioned beside one another in a heel-toe relationship, or may be positioned behind one another in a front-rear orientation. As such, one particular embodiment includes at least two crown located SRFs (1100) positioned on opposite sides of the engineered impact point (EIP) when viewed in a top plan view, as seen in FIG. 31, thereby further selectively increasing the COR and improving the peak stress on the face (500). Traditionally, the COR of the face (500) gets smaller as the measurement point is moved further away from the engineered impact point (EIP); and thus golfers that hit the ball toward the heel side (406) or toe side (408) of the a golf club head do not benefit from a high COR. As such, positioning of the two crown located SRFs (1100) seen in FIG. 30 facilitates additional face deflection for shots struck toward the heel side (406) or toe side (408) of the golf club head (400). Another embodiment, as seen in FIG. 31, incorporates the same principles just discussed into multiple sole located SRFs (1300).

The impact of a club head (400) and a golf ball may be simulated in many ways, both experimentally and via computer modeling. First, an experimental process will be explained because it is easy to apply to any golf club head and is free of subjective considerations. The process involves applying a force to the face (500) distributed over a 0.6 inch diameter centered about the engineered impact point (EIP). A force of 4000 lbf is representative of an approximately 100 mph impact between a club head (400) and a golf ball, and more importantly it is an easy force to apply to the face and reliably reproduce. The club head boundary condition consists of fixing the rear portion (404) of the club head (400) during application of the force. In other words, a club head (400) can easily be secured to a fixture within a material testing machine and the force applied. Generally, the rear portion (404) experiences almost no load during an actual impact with a golf ball, particularly as the "front-to-back" dimension (FB) increases. The peak deflection of the face (500) under the force is easily measured and is very close to

the peak deflection seen during an actual impact, and the peak deflection has a linear correlation to the COR. A strain gauge applied to the face (500) can measure the actual stress. This experimental process takes only minutes to perform and a variety of forces may be applied to any club head (400); further, computer modeling of a distinct load applied over a certain area of a club face (500) is much quicker to simulate than an actual dynamic impact.

A graph of displacement versus load is illustrated in FIG. 44 for a club head having no stress reducing feature (1000), a club head (400) having only a sole located SRF (1300), and a club head (400) having both a crown located SRF (1100) and a sole located SRF (1300), at the following loads of 1000 lbf, 2000 lbf, 3000 lbf, and 4000 lbf, all of which are distributed over a 0.6 inch diameter area centered on the engineered impact point (EIP). The face thickness (530) was held a constant 0.090 inches for each of the three club heads. Incorporation of a crown located SRF (1100) and a sole located SRF (1300) as described herein increases face deflection by over 11% at the 4000 lbf load level, from a value of 0.027 inches to 0.030 inches. In one particular embodiment, the increased deflection resulted in an increase in the characteristic time (CT) of the club head from 187 microseconds to 248 microseconds. A graph of peak face stress versus load is illustrated in FIG. 45 for the same three variations just discussed with respect to FIG. 44. FIG. 45 nicely illustrates that incorporation of a crown located SRF (1100) and a sole located SRF (1300) as described herein reduces the peak face stress by almost 25% at the 4000 lbf load level, from a value of 170.4 ksi to 128.1 ksi. The stress reducing feature (1000) permits the use of a very thin face (500) without compromising the integrity of the club head (400). In fact, the face thickness (530) may vary from 0.050 inches, up to 0.120 inches.

Combining the information seen in FIGS. 44 and 45, a new ratio may be developed; namely, a stress-to-deflection ratio of the peak stress on the face to the displacement at a given load, as seen in FIG. 46. In one embodiment, the stress-to-deflection ratio is less than 5000 ksi per inch of deflection, wherein the approximate impact force is applied to the face (500) over a 0.6 inch diameter, centered on the engineered impact point (EIP), and the approximate impact force is at least 1000 lbf and no more than 4000 lbf, the club head volume is less than 300 cc, and the face thickness (530) is less than 0.120 inches. In yet a further embodiment, the face thickness (530) is less than 0.100 inches and the stress-to-deflection ratio is less than 4500 ksi per inch of deflection; while an even further embodiment has a stress-to-deflection ratio that is less than 4300 ksi per inch of deflection.

In addition to the unique stress-to-deflection ratios just discussed, one embodiment of the present invention further includes a face (500) having a characteristic time of at least 220 microseconds and the head volume is less than 200 cubic centimeters. Even further, another embodiment goes even further and incorporates a face (500) having a characteristic time of at least 240 microseconds, a head volume that is less than 170 cubic centimeters, a face height between the maximum top edge height (TEH) and the minimum lower edge (LEH) that is less than 1.50 inches, and a vertical roll radius between 7 inches and 13 inches, which further increases the difficulty in obtaining such a high characteristic time, small face height, and small volume golf club head.

Those skilled in the art know that the characteristic time, often referred to as the CT, value of a golf club head is limited by the equipment rules of the United States Golf Association (USGA). The rules state that the characteristic time of a club head shall not be greater than 239 microseconds, with a

maximum test tolerance of 18 microseconds. Thus, it is common for golf clubs to be designed with the goal of a 239 microsecond CT, knowing that due to manufacturing variability that some of the heads will have a CT value higher than 239 microseconds, and some will be lower. However, it is critical that the CT value does not exceed 257 microseconds or the club will not conform to the USGA rules. The USGA publication "Procedure for Measuring the Flexibility of a Golf Clubhead," Revision 2.0, Mar. 25, 2005, is the current standard that sets forth the procedure for measuring the characteristic time.

With reference now to FIGS. 47-49, another embodiment of the crown located SRF (1100) may include a CSRF aperture (1200) recessed from the crown (600) and extending through the outer shell. As seen in FIG. 49, the CSRF aperture (1200) is located at a CSRF aperture depth (1250) measured vertically from the top edge height (TEH) toward the center of gravity (CG), keeping in mind that the top edge height (TEH) varies across the face (500) from the heel side (406) to the toe side (408). Therefore, as illustrated in FIG. 49, to determine the CSRF aperture depth (1250) one must first take a section in the front-to-rear direction of the club head (400), which establishes the top edge height (TEH) at this particular location on the face (500) that is then used to determine the CSRF aperture depth (1250) at this particular location along the CSRF aperture (1200). For instance, as seen in FIG. 47, the section that is illustrated in FIG. 49 is taken through the center of gravity (CG) location, which is just one of an infinite number of sections that can be taken between the origin and the towardmost point on the club head (400). Just slightly to the left of the center of gravity (CG) in FIG. 47 is a line representing the face center (FC), if a section such as that of FIG. 49 were taken along the face center (FC) it would illustrate that the top edge height (TEH) is generally the greatest at this point.

At least a portion of the CSRF aperture depth (1250) is greater than zero. This means that at some point along the CSRF aperture (1200), the CSRF aperture (1200) will be located below the elevation of the top of the face (400) directly in front of the point at issue, as illustrated in FIG. 49. In one particular embodiment the CSRF aperture (1200) has a maximum CSRF aperture depth (1250) that is at least ten percent of the Ycg distance. An even further embodiment incorporates a CSRF aperture (1200) that has a maximum CSRF aperture depth (1250) that is at least fifteen percent of the Ycg distance. Incorporation of a CSRF aperture depth (1250) that is greater than zero, and in some embodiments greater than a certain percentage of the Ycg distance, preferably reduces the stress in the face (500) when impacting a golf ball while accommodating temporary flexing and deformation of the crown located SRF (1100) in a stable manner in relation to the CG location, engineered impact point (EIP), and/or outer shell, while maintaining the durability of the face (500) and the crown (600).

The CSRF aperture (1200) has a CSRF aperture width (1240) separating a CSRF leading edge (1220) from a CSRF aperture trailing edge (1230), again measured in a front-to-rear direction as seen in FIG. 49. In one embodiment the CSRF aperture (1200) has a maximum CSRF aperture width (1240) that is at least twenty-five percent of the maximum CSRF aperture depth (1250) to allow preferred flexing and deformation while maintaining durability and stability upon repeated impacts with a golf ball. An even further variation achieves these goals by maintaining a maximum CSRF aperture width (1240) that is less than maximum CSRF aperture depth (1250). In yet another embodiment the CSRF aperture (1200) also has a maximum CSRF aperture width (1240) that

is at least fifty percent of a minimum face thickness (530), while optionally also being less than the maximum face thickness (530).

In furtherance of these desirable properties, the CSRF aperture (1200) has a CSRF aperture length (1210) between a CSRF aperture toe-most point (1212) and a CSRF aperture heel-most point (1216) that is at least fifty percent of the Xcg distance. In yet another embodiment the CSRF aperture length (1210) is at least as great as the heel blade length section (Abl), or even further in another embodiment in which the CSRF aperture length (1210) is also at least fifty percent of the blade length (BL).

Referring again to FIG. 49, the CSRF aperture leading edge (1220) has a CSRF aperture leading edge offset (1222). In one embodiment preferred flexing and deformation occur, while maintaining durability, when the minimum CSRF aperture leading edge offset (1222) is at least ten percent of the difference between the maximum top edge height (TEH) and the minimum lower edge height (LEH). Even further, another embodiment has found preferred characteristics when the minimum CSRF aperture leading edge offset (1222) at least twenty percent of the difference between the maximum top edge height (TEH) and the minimum lower edge height (LEH), and optionally when the maximum CSRF aperture leading edge offset (1222) less than seventy-five percent of the difference between the maximum top edge height (TEH) and the minimum lower edge height (LEH).

Again with reference now to FIGS. 47-49 but now turning our attention to the sole located SRF (1300), an embodiment of the sole located SRF (1300) may include a SSRF aperture (1400) recessed from the sole (700) and extending through the outer shell. As seen in FIG. 49, the SSRF aperture (1400) is located at a SSRF aperture depth (1450) measured vertically from the leading edge height (LEH) toward the center of gravity (CG), keeping in mind that the leading edge height (LEH) varies across the face (500) from the heel side (406) to the toe side (408). Therefore, as illustrated in FIG. 49, to determine the SSRF aperture depth (1450) one must first take a section in the front-to-rear direction of the club head (400), which establishes the leading edge height (LEH) at this particular location on the face (500) that is then used to determine the SSRF aperture depth (1450) at this particular location along the SSRF aperture (1400). For instance, as seen in FIG. 47, the section that is illustrated in FIG. 49 is taken through the center of gravity (CG) location, which is just one of an infinite number of sections that can be taken between the origin and the towardmost point on the club head (400). Just slightly to the left of the center of gravity (CG) in FIG. 47 is a line representing the face center (FC), if a section such as that of FIG. 49 were taken along the face center (FC) it would illustrate that the leading edge height (LEH) is generally the least at this point.

At least a portion of the SSRF aperture depth (1450) is greater than zero. This means that at some point along the SSRF aperture (1400), the SSRF aperture (1400) will be located above the elevation of the bottom of the face (400) directly in front of the point at issue, as illustrated in FIG. 49. In one particular embodiment the SSRF aperture (1400) has a maximum SSRF aperture depth (1450) that is at least ten percent of the Ycg distance. An even further embodiment incorporates a SSRF aperture (1400) that has a maximum SSRF aperture depth (1450) that is at least fifteen percent of the Ycg distance. Incorporation of a SSRF aperture depth (1450) that is greater than zero, and in some embodiments greater than a certain percentage of the Ycg distance, preferably reduces the stress in the face (500) when impacting a golf ball while accommodating temporary flexing and deforma-

tion of the sole located SRF (1300) in a stable manner in relation to the CG location, engineered impact point (EIP), and/or outer shell, while maintaining the durability of the face (500) and the sole (700).

The SSRF aperture (1400) has a SSRF aperture width (1420) separating a SSRF leading edge (1420) from a SSRF aperture trailing edge (1430), again measured in a front-to-rear direction as seen in FIG. 49. In one embodiment the SSRF aperture (1400) has a maximum SSRF aperture width (1440) that is at least twenty-five percent of the maximum SSRF aperture depth (1450) to allow preferred flexing and deformation while maintaining durability and stability upon repeated impacts with a golf ball. An even further variation achieves these goals by maintaining a maximum SSRF aperture width (1440) that is less than maximum SSRF aperture depth (1450). In yet another embodiment the SSRF aperture (1400) also has a maximum SSRF aperture width (1440) that is at least fifty percent of a minimum face thickness (530), while optionally also being less than the maximum face thickness (530).

In furtherance of these desirable properties, the SSRF aperture (1400) has a SSRF aperture length (1410) between a SSRF aperture toe-most point (1412) and a SSRF aperture heel-most point (1416) that is at least fifty percent of the Xcg distance. In yet another embodiment the SSRF aperture length (1410) is at least as great as the heel blade length section (Abl), or even further in another embodiment in which the SSRF aperture length (1410) is also at least fifty percent of the blade length (BL).

Referring again to FIG. 49, the SSRF aperture leading edge (1420) has a SSRF aperture leading edge offset (1422). In one embodiment preferred flexing and deformation occur, while maintaining durability, when the minimum SSRF aperture leading edge offset (1422) is at least ten percent of the difference between the maximum top edge height (TEH) and the minimum lower edge height (LEH). Even further, another embodiment has found preferred characteristics when the minimum SSRF aperture leading edge offset (1422) at least twenty percent of the difference between the maximum top edge height (TEH) and the minimum lower edge height (LEH), and optionally when the maximum SSRF aperture leading edge offset (1422) less than seventy-five percent of the difference between the maximum top edge height (TEH) and the minimum lower edge height (LEH).

As previously discussed, the SRFs (1100, 1300) may be subsequently filled with a secondary material, as seen in FIG. 51, or covered, such that the volume is not visible to a golfer, similarly, the apertures (1200, 1400) may be covered or filled so that they are not noticeable to a user, and so that material and moisture is not unintentionally introduced into the interior of the club head. In other words, one need not be able to view the inside of the club head through the aperture (1200, 1400) in order for the aperture (1200, 1400) to exist. The apertures (1200, 1400) may be covered by a badge extending over the apertures (1200, 1400), or a portion of such cover may extend into the apertures (1200, 1400), as seen in FIG. 52. If a portion of the cover extends into the aperture (1200, 1400) then that portion should be compressible and have a compressive strength that is less than fifty percent of the compressive strength of the outer shell. A badge extending over the aperture (1200, 1400) may be attached to the outer shell on only one side of the aperture (1200, 1400), or on both sides of the aperture (1200, 1400) if the badge is not rigid or utilizes non-rigid connection methods to secure the badge to the outer shell.

The size, location, and configuration of the CSRF aperture (1200) and the SSRF aperture (1400) are selected to prefer-

ably reduce the stress in the face (500) when impacting a golf ball while accommodating temporary flexing and deformation of the crown located SRF (1100) and sole located SRF (1300) in a stable manner in relation to the CG location, and/or origin point, while maintaining the durability of the face (500), the crown (600), and the sole (700). While the generally discussed apertures (1200, 1400) of FIGS. 47-49 are illustrated in the bottom wall of the SRF's (1100, 1300), the apertures (1200, 1400) may be located at other locations in the SRF's (1100, 1300) including the front wall as seen in the CSRF aperture (1100) of FIG. 50 and both the CSRF aperture (1200) and SSRF aperture (1400) of FIG. 53, as well as the rear wall as seen in the SSRF aperture (1400) of FIG. 50.

As previously explained, the golf club head (100) has a blade length (BL) that is measured horizontally from the origin point toward the toe side of the golf club head a distance that is parallel to the face and the ground plane (GP) to the most distant point on the golf club head in this direction. In one particular embodiment, the golf club head (100) has a blade length (BL) of at least 3.1 inches, a heel blade length section (Abl) is at least 1.1 inches, and a club moment arm (CMA) of less than 1.3 inches, thereby producing a long blade length golf club having reduced face stress, and improved characteristic time qualities, while not being burdened by the deleterious effects of having a large club moment arm (CMA), as is common in oversized fairway woods. The club moment arm (CMA) has a significant impact on the ball flight of off-center hits. Importantly, a shorter club moment arm (CMA) produces less variation between shots hit at the engineered impact point (EIP) and off-center hits. Thus, a golf ball struck near the heel or toe of the present invention will have launch conditions more similar to a perfectly struck shot. Conversely, a golf ball struck near the heel or toe of an oversized fairway wood with a large club moment arm (CMA) would have significantly different launch conditions than a ball struck at the engineered impact point (EIP) of the same oversized fairway wood. Generally, larger club moment arm (CMA) golf clubs impart higher spin rates on the golf ball when perfectly struck in the engineered impact point (EIP) and produce larger spin rate variations in off-center hits. Therefore, yet another embodiment incorporate a club moment arm (CMA) that is less than 1.1 inches resulting in a golf club with more efficient launch conditions including a lower ball spin rate per degree of launch angle, thus producing a longer ball flight.

Conventional wisdom regarding increasing the Zcg value to obtain club head performance has proved to not recognize that it is the club moment arm (CMA) that plays a much more significant role in golf club performance and ball flight. Controlling the club moments arm (CMA), along with the long blade length (BL), long heel blade length section (Abl), while improving the club head's ability to distribute the stresses of impact and thereby improving the characteristic time across the face, particularly off-center impacts, yields launch conditions that vary significantly less between perfect impacts and off-center impacts than has been seen in the past. In another embodiment, the ratio of the golf club head front-to-back dimension (FB) to the blade length (BL) is less than 0.925, as seen in FIGS. 6 and 13. In this embodiment, the limiting of the front-to-back dimension (FB) of the club head (100) in relation to the blade length (BL) improves the playability of the club, yet still achieves the desired high improvements in characteristic time, face deflection at the heel and toe sides, and reduced club moment arm (CMA). The reduced front-to-back dimension (FB), and associated reduced Zcg, of the present invention also significantly reduces dynamic lofting

of the golf club head. Increasing the blade length (BL) of a fairway wood, while decreasing the front-to-back dimension (FB) and incorporating the previously discussed characteristics with respect to the stress reducing feature (1000), minimum heel blade length section (Abl), and maximum club moment arm (CMA), produces a golf club head that has improved playability that would not be expected by one practicing conventional design principles. In yet a further embodiment a unique ratio of the heel blade length section (Abl) to the golf club head front-to-back dimension (FB) has been identified and is at least 0.32. Yet another embodiment incorporates a ratio of the club moment arm (CMA) to the heel blade length section (Abl). In this embodiment the ratio of club moment arm (CMA) to the heel blade length section (Abl) is less than 0.9. Still a further embodiment uniquely characterizes the present fairway wood golf club head with a ratio of the heel blade length section (Abl) to the blade length (BL) that is at least 0.33. A further embodiment has recognized highly beneficial club head performance regarding launch conditions when the transfer distance (TD) is at least 10 percent greater than the club moment arm (CMA). Even further, a particularly effective range for fairway woods has been found to be when the transfer distance (TD) is 10 percent to 40 percent greater than the club moment arm (CMA). This range ensures a high face closing moment (MOI_{fc}) such that bringing club head square at impact feels natural and takes advantage of the beneficial impact characteristics associated with the short club moment arm (CMA) and CG location.

Referring now to FIG. 10, in one embodiment it was found that a particular relationship between the top edge height (TEH) and the Ycg distance further promotes desirable performance and feel. In this embodiment a preferred ratio of the Ycg distance to the top edge height (TEH) is less than 0.40; while still achieving a long blade length of at least 3.1 inches, including a heel blade length section (Abl) that is at least 1.1 inches, a club moment arm (CMA) of less than 1.1 inches, and a transfer distance (TD) of at least 1.2 inches, wherein the transfer distance (TD) is between 10 percent to 40 percent greater than the club moment arm (CMA). This ratio ensures that the CG is below the engineered impact point (EIP), yet still ensures that the relationship between club moment arm (CMA) and transfer distance (TD) are achieved with club head design having a stress reducing feature (1000), a long blade length (BL), and long heel blade length section (Abl). As previously mentioned, as the CG elevation decreases the club moment arm (CMA) increases by definition, thereby again requiring particular attention to maintain the club moment arm (CMA) at less than 1.1 inches while reducing the Ycg distance, and a significant transfer distance (TD) necessary to accommodate the long blade length (BL) and heel blade length section (Abl). In an even further embodiment, a ratio of the Ycg distance to the top edge height (TEH) of less than 0.375 has produced even more desirable ball flight properties. Generally the top edge height (TEH) of fairway wood golf clubs is between 1.1 inches and 2.1 inches.

In fact, most fairway wood type golf club heads fortunate to have a small Ycg distance are plagued by a short blade length (BL), a small heel blade length section (Abl), and/or long club moment arm (CMA). With reference to FIG. 3, one particular embodiment achieves improved performance with the Ycg distance less than 0.65 inches, while still achieving a long blade length of at least 3.1 inches, including a heel blade length section (Abl) that is at least 1.1 inches, a club moment arm (CMA) of less than 1.1 inches, and a transfer distance (TD) of at least 1.2 inches, wherein the transfer distance (TD) is between 10 percent to 40 percent greater than the club moment arm (CMA). As with the prior disclosure, these rela-

tionships are a delicate balance among many variables, often going against traditional club head design principles, to obtain desirable performance. Still further, another embodiment has maintained this delicate balance of relationships while even further reducing the Ycg distance to less than 0.60 inches.

As previously touched upon, in the past the pursuit of high MOI_y fairway woods led to oversized fairway woods attempting to move the CG as far away from the face of the club, and as low, as possible. With reference again to FIG. 8, this particularly common strategy leads to a large club moment arm (CMA), a variable that the present embodiment seeks to reduce. Further, one skilled in the art will appreciate that simply lowering the CG in FIG. 8 while keeping the Zcg distance, seen in FIGS. 2 and 6, constant actually increases the length of the club moment arm (CMA). The present invention is maintaining the club moment arm (CMA) at less than 1.1 inches to achieve the previously described performance advantages, while reducing the Ycg distance in relation to the top edge height (TEH); which effectively means that the Zcg distance is decreasing and the CG position moves toward the face, contrary to many conventional design goals.

As explained throughout, the relationships among many variables play a significant role in obtaining the desired performance and feel of a golf club. One of these important relationships is that of the club moment arm (CMA) and the transfer distance (TD). One particular embodiment has a club moment arm (CMA) of less than 1.1 inches and a transfer distance (TD) of at least 1.2 inches; however in a further particular embodiment this relationship is even further refined resulting in a fairway wood golf club having a ratio of the club moment arm (CMA) to the transfer distance (TD) that is less than 0.75, resulting in particularly desirable performance. Even further performance improvements have been found in an embodiment having the club moment arm (CMA) at less than 1.0 inch, and even more preferably, less than 0.95 inches. A somewhat related embodiment incorporates a mass distribution that yields a ratio of the Xcg distance to the Ycg distance of at least two.

A further embodiment achieves a Ycg distance of less than 0.65 inches, thereby requiring a very light weight club head shell so that as much discretionary mass as possible may be added in the sole region without exceeding normally acceptable head weights, as well as maintaining the necessary durability. In one particular embodiment this is accomplished by constructing the shell out of a material having a density of less than 5 g/cm³, such as titanium alloy, nonmetallic composite, or thermoplastic material, thereby permitting over one-third of the final club head weight to be discretionary mass located in the sole of the club head. One such nonmetallic composite may include composite material such as continuous fiber pre-preg material (including thermosetting materials or thermoplastic materials for the resin). In yet another embodiment the discretionary mass is composed of a second material having a density of at least 15 g/cm³, such as tungsten. An even further embodiment obtains a Ycg distance is less than 0.55 inches by utilizing a titanium alloy shell and at least 80 grams of tungsten discretionary mass, all the while still achieving a ratio of the Ycg distance to the top edge height (TEH) is less than 0.40, a blade length (BL) of at least 3.1 inches with a heel blade length section (Abl) that is at least 1.1 inches, a club moment arm (CMA) of less than 1.1 inches, and a transfer distance (TD) of at least 1.2 inches.

A further embodiment recognizes another unusual relationship among club head variables that produces a fairway wood type golf club exhibiting exceptional performance and feel. In this embodiment it has been discovered that a heel

blade length section (Abl) that is at least twice the Ycg distance is desirable from performance, feel, and aesthetics perspectives. Even further, a preferably range has been identified by appreciating that performance, feel, and aesthetics get less desirable as the heel blade length section (Abl) exceeds 2.75 times the Ycg distance. Thus, in this one embodiment the heel blade length section (Abl) should be 2 to 2.75 times the Ycg distance.

Similarly, a desirable overall blade length (BL) has been linked to the Ycg distance. In yet another embodiment preferred performance and feel is obtained when the blade length (BL) is at least 6 times the Ycg distance. Such relationships have not been explored with conventional golf clubs because exceedingly long blade lengths (BL) would have resulted. Even further, a preferable range has been identified by appreciating that performance and feel become less desirable as the blade length (BL) exceeds 7 times the Ycg distance. Thus, in this one embodiment the blade length (BL) should be 6 to 7 times the Ycg distance.

Just as new relationships among blade length (BL) and Ycg distance, as well as the heel blade length section (Abl) and Ycg distance, have been identified; another embodiment has identified relationships between the transfer distance (TD) and the Ycg distance that produce a particularly playable golf club. One embodiment has achieved preferred performance and feel when the transfer distance (TD) is at least 2.25 times the Ycg distance. Even further, a preferable range has been identified by appreciating that performance and feel deteriorate when the transfer distance (TD) exceeds 2.75 times the Ycg distance. Thus, in yet another embodiment the transfer distance (TD) should be within the relatively narrow range of 2.25 to 2.75 times the Ycg distance for preferred performance and feel.

All the ratios used in defining embodiments of the present invention involve the discovery of unique relationships among key club head engineering variables that are inconsistent with merely striving to obtain a high MOI or low CG using conventional golf club head design wisdom. Numerous alterations, modifications, and variations of the preferred embodiments disclosed herein will be apparent to those skilled in the art and they are all anticipated and contemplated to be within the spirit and scope of the instant invention. Further, although specific embodiments have been described in detail, those with skill in the art will understand that the preceding embodiments and variations can be modified to incorporate various types of substitute and or additional or alternative materials, relative arrangement of elements, and dimensional configurations. Accordingly, even though only few variations of the present invention are described herein, it is to be understood that the practice of such additional modifications and variations and the equivalents thereof, are within the spirit and scope of the invention as defined in the following claims.

We claim:

1. A golf club head (400) comprising:

- (i) a face (500) positioned at a front portion (402) of the golf club head (400) where the golf club head (400) impacts a golf ball, wherein the face (500) has a loft of at least 6 degrees, and wherein the face (400) includes an engineered impact point (EIP), a top edge height (TEH), and a lower edge height (LEH);
- (ii) a sole (700) positioned at a bottom portion of the golf club head (400);
- (iii) a crown (600) positioned at a top portion of the golf club head (400);
- (iv) a skirt (800) positioned around a portion of a periphery of the golf club head (400) between the sole (700) and

the crown (600), wherein the face (500), sole (700), crown (600), and skirt (800) define an outer shell that further defines a head volume, and wherein the golf club head (400) has a rear portion (404) opposite the face (500);

- (v) a bore having a center that defines a shaft axis (SA) which intersects with a horizontal ground plane (GP) to define an origin point, wherein the bore is located at a heel side (406) of the golf club head (400) and receives a shaft distal end (220) for attachment to the golf club head (400), and wherein a toe side (408) of the golf club head (400) is located opposite of the heel side (406);
 - (vi) a club head mass of less than 310 grams;
 - (vii) a center of gravity (CG) located:
 - (a) vertically toward the crown (600) of the golf club head (400) from the origin point a distance Ycg;
 - (b) horizontally from the origin point toward the toe side (408) of the golf club head (400) a distance Xcg that is generally parallel to the face (500) and the ground plane (GP); and
 - (c) a distance Zcg from the origin toward the rear portion (404) in a direction generally orthogonal to the vertical direction used to measure Ycg and generally orthogonal to the horizontal direction used to measure Xcg;
 - (viii) the engineered impact point (EIP) located:
 - (a) vertically toward the crown (600) of the golf club head (400) from the origin point a distance Yeip;
 - (b) horizontally from the origin point toward the toe side (408) of the golf club head (400) a distance Xeip that is generally parallel to the face (500) and the ground plane (GP); and
 - (c) a distance Zeip from the origin toward the face (500) in a direction generally orthogonal to the vertical direction used to measure Ycg and generally orthogonal to the horizontal direction used to measure Xcg;
 - (ix) a stress reducing feature (1000) including at least a toe located SRF (1500) located at least partially on the skirt (800) on a toe portion of the club head (400), wherein the toe located SRF (1500) has a TSRF length (1510) between a TSRF crown-most point (1512) and a TSRF sole-most point (1516), a TSRF width (1540), a TSRF depth (1550), a TSRF wall thickness (1565), and a TSRF cross-sectional area (1570), wherein
 - (a) the TSRF crown-most point (1512) is at an elevation greater than the Ycg distance and the Yeip distance, and the TSRF sole-most point (1516) is at an elevation less than the Ycg distance and the Yeip distance;
 - (b) the maximum TSRF width (1540) is at least ten percent of the Zcg distance, and the maximum TSRF depth (1550) is at least ten percent of the Ycg distance;
 - (c) at least one TSRF cross-sectional area (1570) taken at an elevation greater than the Ycg distance is greater than at least one TSRF cross-sectional area (1570) taken at an elevation below the Ycg distance; and
 - (d) a maximum TSRF depth (1550) is greater than a maximum TSRF width (1540).
2. The golf club head (400) of claim 1, wherein the maximum TSRF depth (1550) at an elevation greater than the Ycg distance is at least fifty percent greater than the maximum TSRF depth (1550) taken at an elevation below the Ycg distance.
3. The golf club head (400) of claim 2, wherein the maximum TSRF depth (1550) is at least twenty percent of the Ycg distance.

4. The golf club head (400) of claim 3, wherein the minimum TSRF depth (1550) is greater than a maximum face thickness (530).

5. The golf club head (400) of claim 3, wherein a TSRF cross-sectional area (1570) at the TSRF sole-most point (1516) is at least fifty percent less than TSRF cross-sectional area (1570) at the TSRF crown-most point (1512).

6. The golf club head (400) of claim 3, wherein the TSRF length (1510) is greater than the Xcg distance, the Ycg distance, and the Zcg distance.

7. The golf club head (400) of claim 6, wherein the TSRF length (1510) is less than twice the Ycg distance.

8. The golf club head (400) of claim 6, wherein the TSRF length (1510) is at least seven times the maximum TSRF width (1540).

9. The golf club head (400) of claim 1, wherein the TSRF wall thickness (1565) is less than sixty percent of a maximum face thickness (530).

10. The golf club head (400) of claim 1, wherein the toe located SRF (1500) is located entirely in front of a shaft axis plane (SAP).

11. The golf club head (400) of claim 1, wherein a shaft axis plane (SAP) passes through a portion of the toe located SRF (1500).

12. The golf club head (400) of claim 1, further including a shaft connection system socket (2000) extending from the bottom portion of the golf club head (400) into the interior of the outer shell toward the top portion of the club head (400), wherein the shaft connection system socket (2000) has a socket crown-most point (2010) at an elevation less than the elevation of the TSRF crown-most point (1512).

13. The golf club head (400) of claim 12, wherein the shaft connection system socket (2000) has a socket wall thickness (2020), and a minimum socket wall thickness (2020) is at least fifty percent greater than a minimum TSRF wall thickness (1565).

14. The golf club head (400) of claim 12, wherein the shaft connection system socket (2000) has a socket depth (2040), and a maximum socket depth (2040) is greater than the maximum TSRF depth (1550).

15. The golf club head (400) of claim 12, wherein the socket crown-most point (2010) is at an elevation greater than the elevation of the TSRF sole-most point (1516).

16. The golf club head (400) of claim 15, wherein the socket crown-most point (2010) is at an elevation less than the Yeip distance.

17. The golf club head (400) of claim 12, wherein shaft connection system socket (2000) has a socket volume and the toe located SRF (1500) has a TSRF volume, and the socket volume is less than the TSRF volume.

18. The golf club head (400) of claim 1, wherein the stress reducing feature (600) further includes a heel located SRF (1700) located at least partially on the skirt (800) on a heel portion of the club head (400), wherein the heel located SRF (1700) has a HSRF length (1710) between a HSRF crown-most point (1712) and a HSRF sole-most point (1716), a HSRF width (1740), and a HSRF depth (1750), wherein a maximum TSRF depth (1550) is greater than a maximum HSRF depth (1750), and the HSRF sole-most point (1716) is at an elevation less than the Ycg distance and the Yeip distance.

19. The golf club head (400) of claim 18, wherein the maximum TSRF depth (1550) at least twice the maximum HSRF depth (1750).

20. The golf club head (400) of claim 19, wherein elevation of the HSRF crown-most point (1712) is greater than the Ycg distance.

21. The golf club head (400) of claim 1, further including a shaft connection system socket (2000) extending from the bottom portion of the golf club head (400) into the interior of the outer shell toward the top portion of the club head (400), wherein a portion of the shaft connection system socket (2000) connects to the heel located SRF (1700) at a socket-to-HSRF junction (2030).

22. The golf club head (400) of claim 21, wherein the socket-to-HSRF junction (2030) has a lineal junction length (2035) that is at least twenty-five percent of the HSRF length (1710).

23. The golf club head (400) of claim 22, wherein the lineal junction length (2035) that is at least fifty percent of the HSRF length (1710).

24. The golf club head (400) of claim 21, wherein the shaft connection system socket (2000) has a socket wall thickness (2020), and a minimum socket wall thickness (2020) is at least fifty percent greater than a minimum HSRF wall thickness (1765).

25. The golf club head (400) of claim 21, wherein the shaft connection system socket (2000) has a socket depth (2040), and a maximum socket depth (2040) is at least twice the maximum HSRF depth (1750).

* * * * *