



US00D546115S

(12) **United States Design Patent** (10) **Patent No.:** **US D546,115 S**  
**Henry** (45) **Date of Patent:** **\*\* Jul. 10, 2007**

(54) **RACE CAR THEMED BARBECUE GRILL**

D497,076 S 10/2004 Sutcliff

(75) Inventor: **Lowell M. Henry**, Redondo Beach, CA (US)

(73) Assignee: **AJML Company, LLC**, Redondo Beach, CA (US)

(\*\*) Term: **14 Years**

(21) Appl. No.: **29/252,067**

(22) Filed: **Jan. 18, 2006**

(51) **LOC (8) Cl.** ..... **07-02**

(52) **U.S. Cl.** ..... **D7/332**

(58) **Field of Classification Search** ..... D7/332-337, D7/402-405; D23/335-336, 343; 126/500, 126/506, 519, 40, 50, 9 R, 9 B, 25 R, 25 A, 126/304 R, 305, 268, 276, 41 R, 37 R; 99/445, 99/448, 481-482; 248/128-129; 312/249.8, 312/249.13, 351.2; D6/511, 574

See application file for complete search history.

(56) **References Cited**

**U.S. PATENT DOCUMENTS**

D395,982 S	7/1998	Dunn
D429,944 S	8/2000	Alle
D436,284 S	1/2001	Mak
D442,818 S	5/2001	Cragg
D485,115 S	1/2004	Barrett

**OTHER PUBLICATIONS**

The BBQ Report. "Barbecue under the hood" [online], [retrieved Jan. 10, 2007, posted Aug. 15, 2005]. Retrieved from the Internet <http://www.bbqreport.com/barbecue/barbecue-grills/>.\*

\* cited by examiner

*Primary Examiner*—Ruth McInroy  
(74) *Attorney, Agent, or Firm*—Gallagher & Dawsey Co, LPA; David J. Dawsey; Michael J. Gallagher

(57) **CLAIM**

I claim the ornamental design for a race car themed barbecue grill, as shown and described.

**DESCRIPTION**

FIG. 1 is a left side isometric view of a race car themed barbecue grill showing my new design;

FIG. 2 is a front elevation view thereof;

FIG. 3 is a right side elevation view thereof;

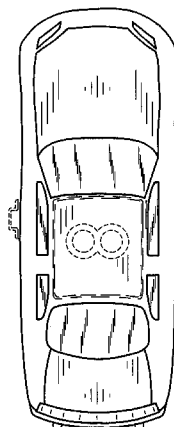
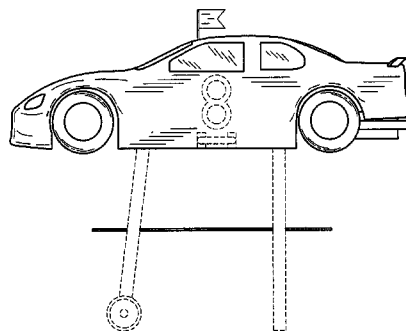
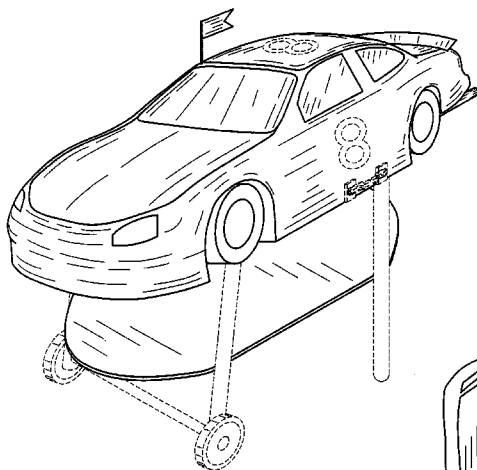
FIG. 4 is a top plan view thereof;

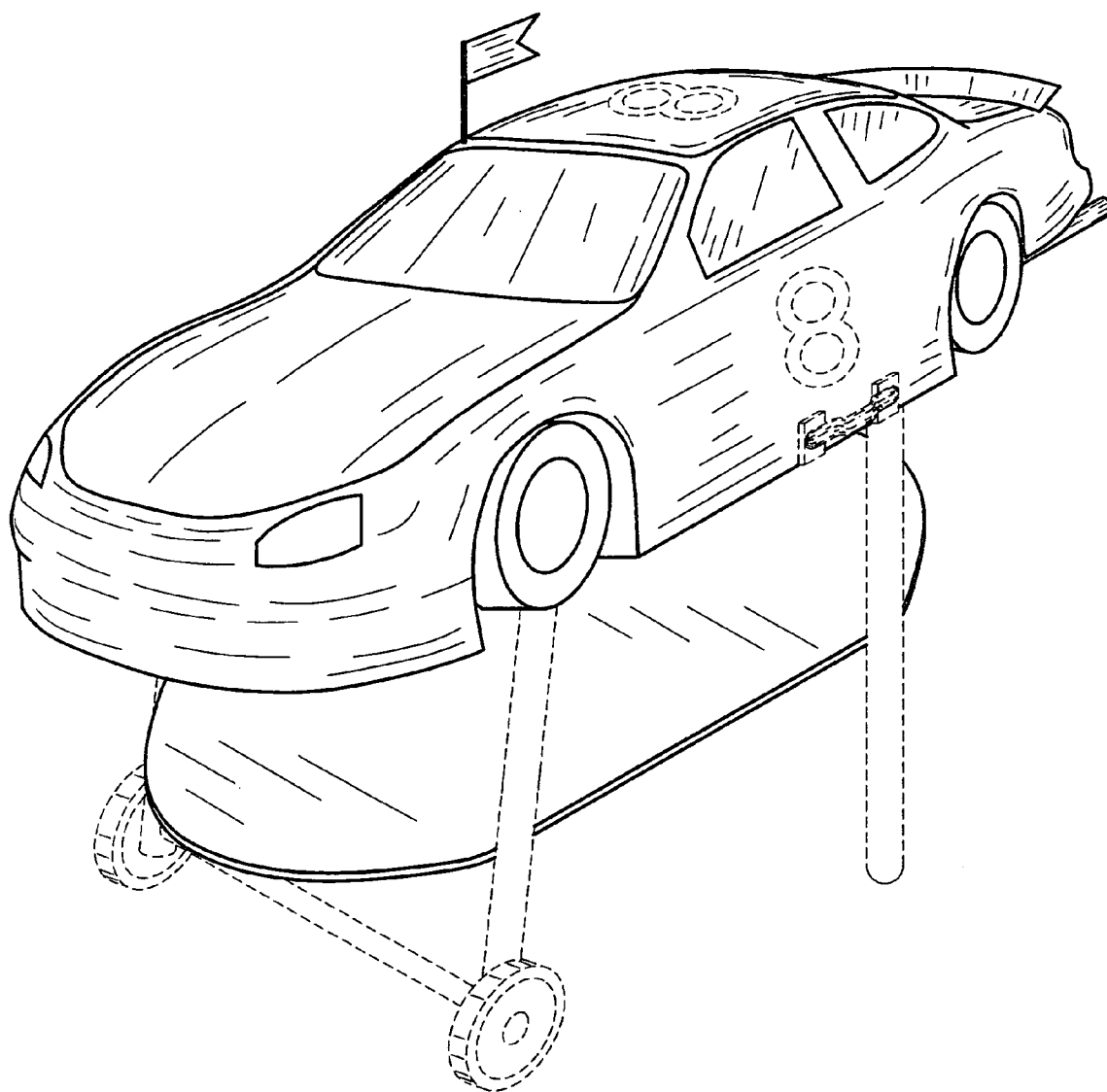
FIG. 5 is a bottom plan view thereof; and,

FIG. 6 is a rear elevation view thereof.

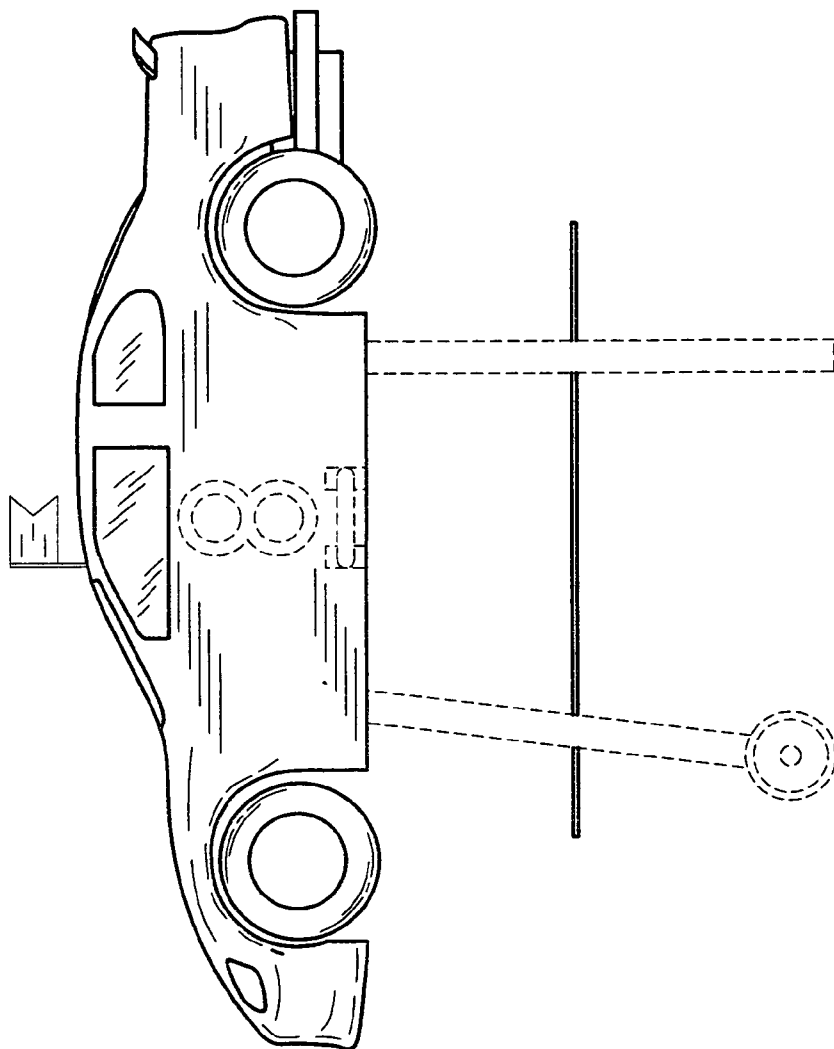
The broken lines are for illustrative purposes only and form no part of the claimed design.

**1 Claim, 3 Drawing Sheets**

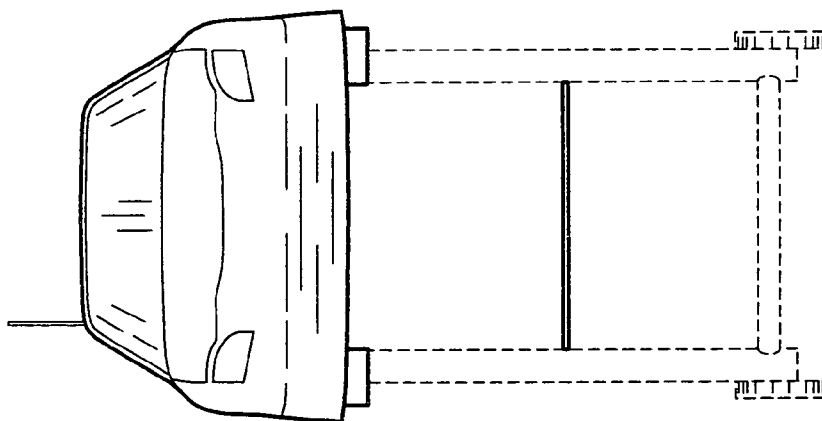




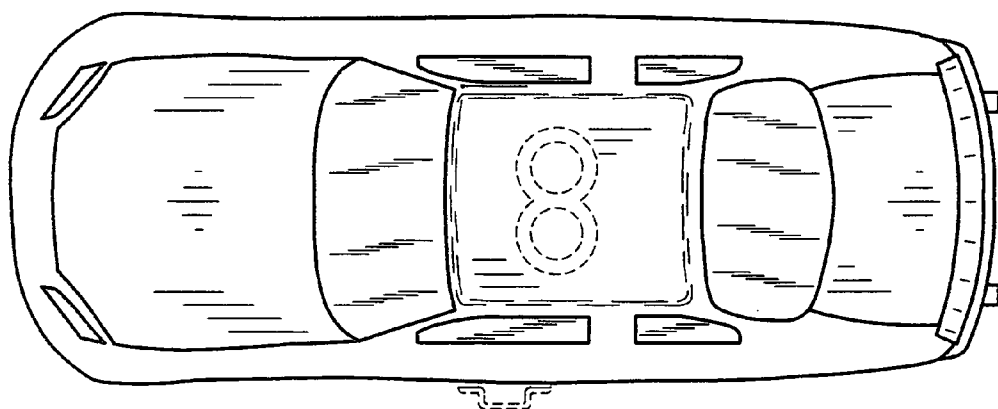
**FIG. 1**



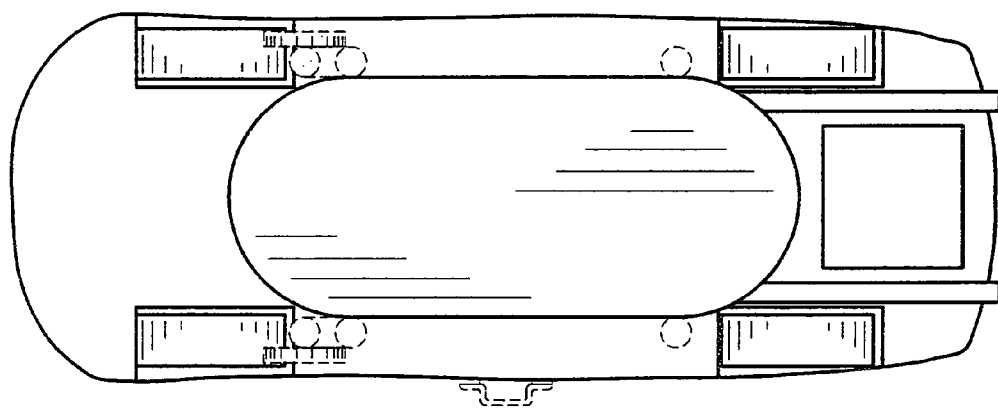
*FIG. 2*



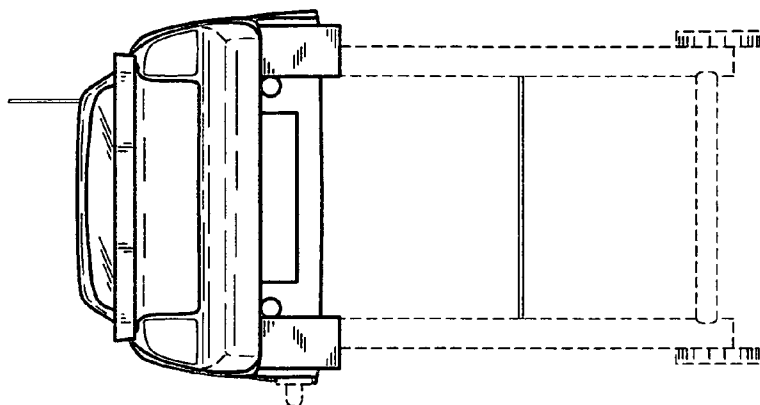
*FIG. 3*



**FIG. 4**



**FIG. 5**



**FIG. 6**