



US00D587904S

(12) **United States Design Patent**
Sherrell et al.

(10) **Patent No.:** **US D587,904 S**
(45) **Date of Patent:** **** Mar. 10, 2009**

(54) **PORTION OF A TRAVEL CASE SUPPORT**

(75) Inventors: **Gary Sherrell**, Maple Valley, WA (US);
Michael J. Baum, Seattle, WA (US);
William Pangburn, Renton, WA (US);
Adam Smith, Seattle, WA (US);
Cameron Smith, Seattle, WA (US);
Glenn Johnson, Mercer Island, WA (US);
Bryan Cabatic, Shoreline, WA (US)

(73) Assignee: **Club Glider Holdings, LLC**, Maple Valley, WA (US)

(**) Term: **14 Years**

(21) Appl. No.: **29/303,411**

(22) Filed: **Feb. 8, 2008**

(51) **LOC (9) Cl.** **03-01**

(52) **U.S. Cl.** **D3/318**

(58) **Field of Classification Search** D3/321,
D3/201, 272, 315, 323, 318; 190/18 A, 122;
D9/501

See application file for complete search history.

(56) **References Cited**

U.S. PATENT DOCUMENTS

D370,997	S	*	6/1996	Hsieh	D3/318
5,568,848	A	*	10/1996	Liang	190/18 A
D379,016	S	*	4/1997	Wilson	D34/24
D438,011	S	*	2/2001	Shick	D3/318
6,182,981	B1	*	2/2001	Kuo	280/37
D487,543	S	*	3/2004	Chang	D3/255
D497,480	S	*	10/2004	Drew et al.	D3/318

6,869,086	B2	*	3/2005	Sadow	280/37
D511,043	S		11/2005	Herold		
7,014,020	B2	*	3/2006	Tamura	190/15.1
7,188,714	B1		3/2007	Herold		
7,219,902	B1		5/2007	Herold		
D570,601	S	*	6/2008	Drew et al.	D3/318
2004/0216970	A1	*	11/2004	Sherrell et al.	190/18 A
2006/0237108	A1		10/2006	Herold		

* cited by examiner

Primary Examiner—Holly H Baynham

Assistant Examiner—Sheryl Lane

(74) *Attorney, Agent, or Firm*—David J. Dawsey; Michael J. Gallagher; Gallagher & Dawsey Co., L.P.A.

(57) **CLAIM**

We claim the ornamental design for a portion of a travel case support, as shown and described.

DESCRIPTION

FIG. 1 is an isometric view of a portion of a travel case support showing our new design;

FIG. 2 is a top plan view thereof;

FIG. 3 is a bottom plan view thereof;

FIG. 4 is a front elevation view thereof;

FIG. 5 is a rear elevation view thereof;

FIG. 6 is a left side elevation view thereof; and,

FIG. 7 is a right side elevation view thereof.

The broken lines are for illustrative purposes only and form no part of the claimed design.

1 Claim, 5 Drawing Sheets

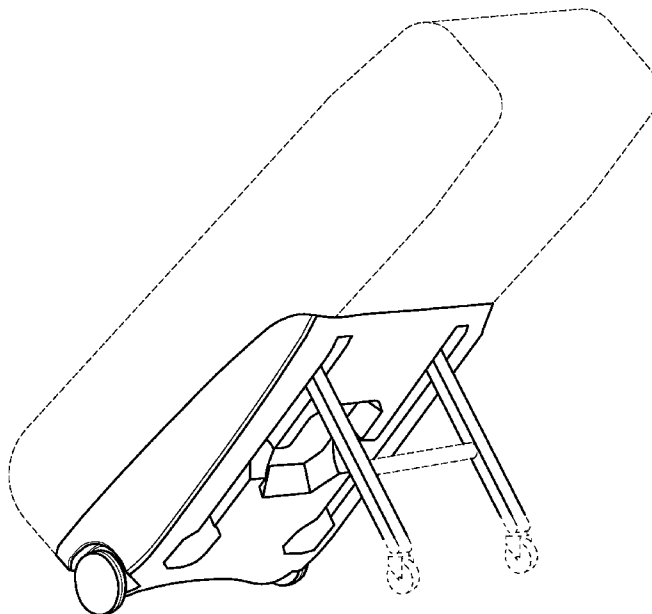

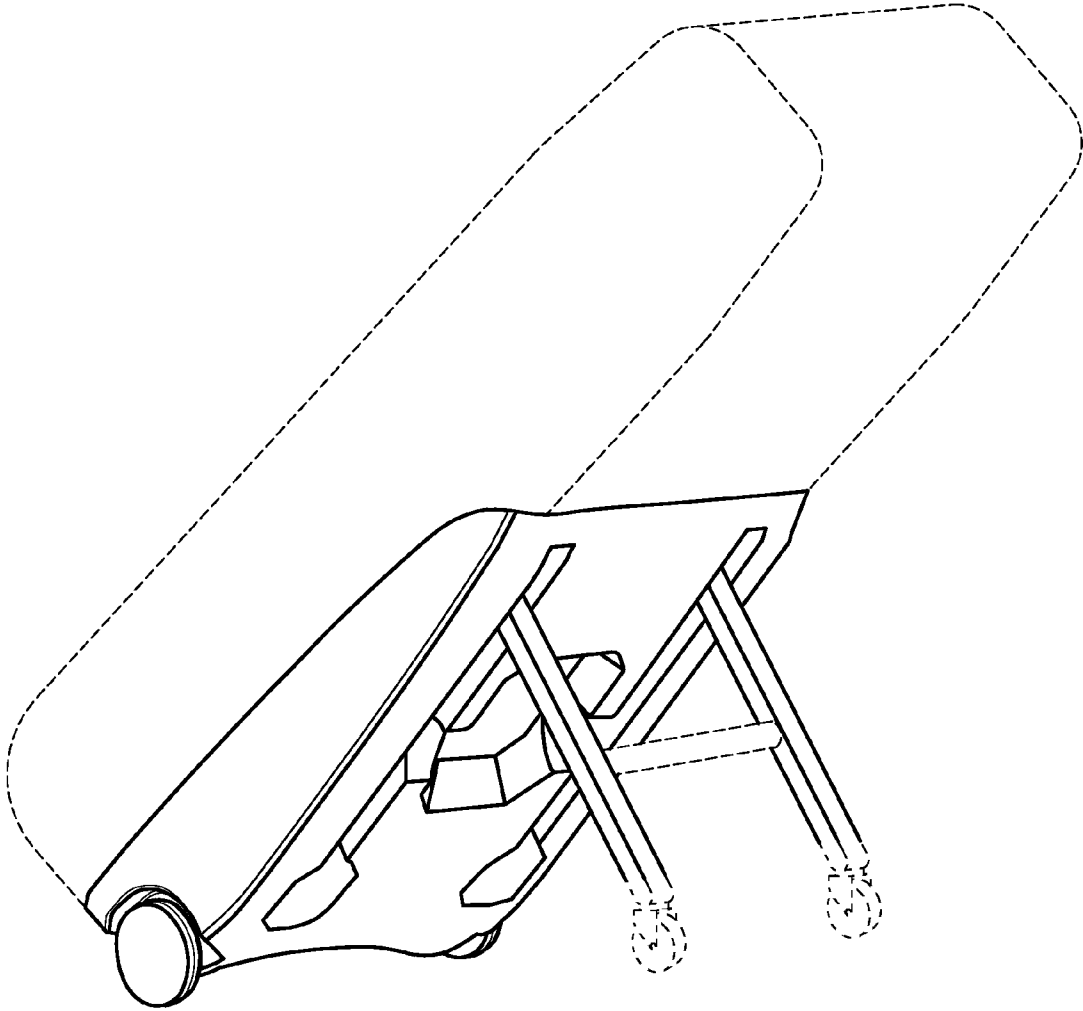

Fig. 1

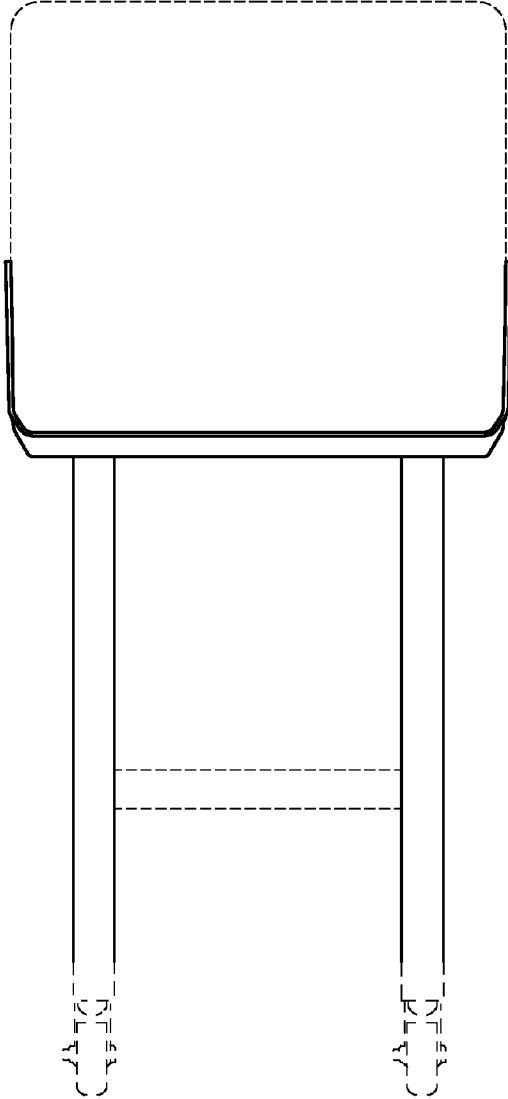

Fig. 2

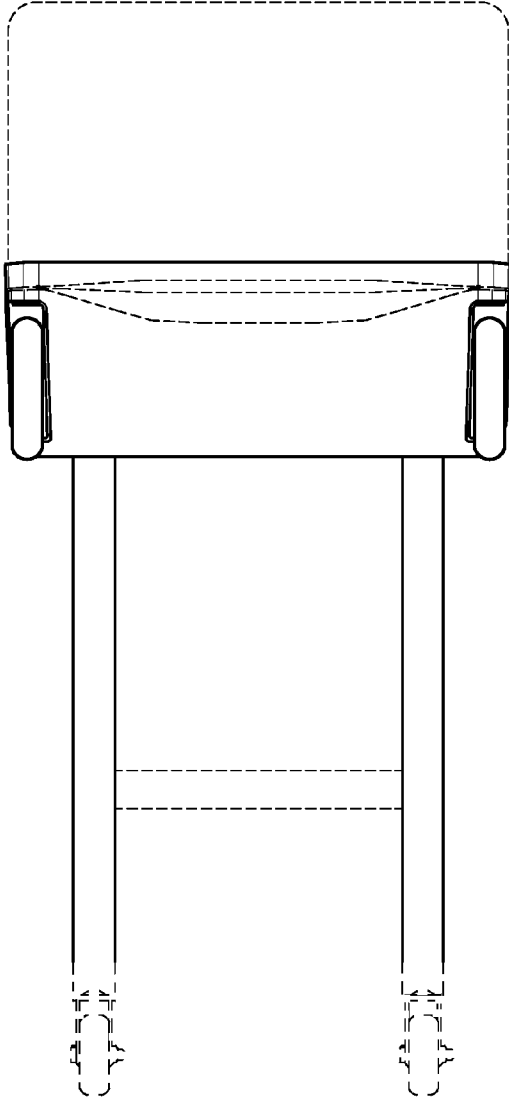

Fig. 3

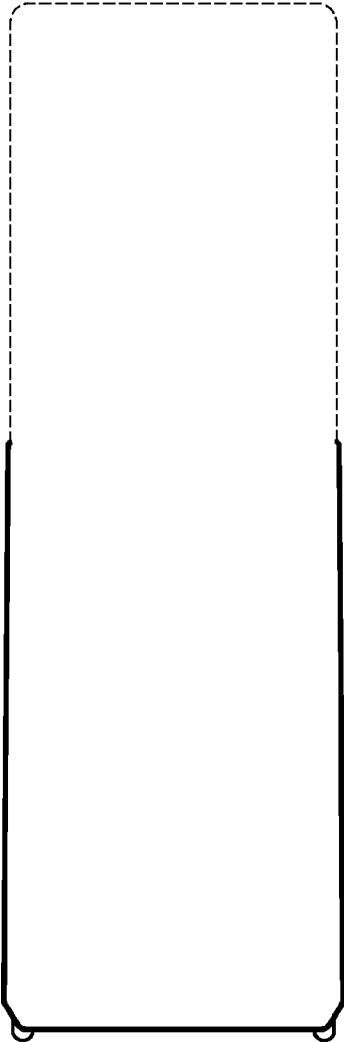

Fig. 4

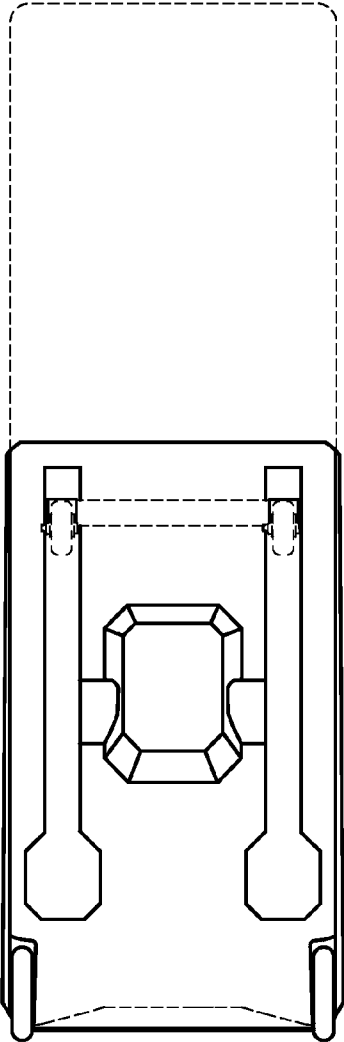

Fig. 5

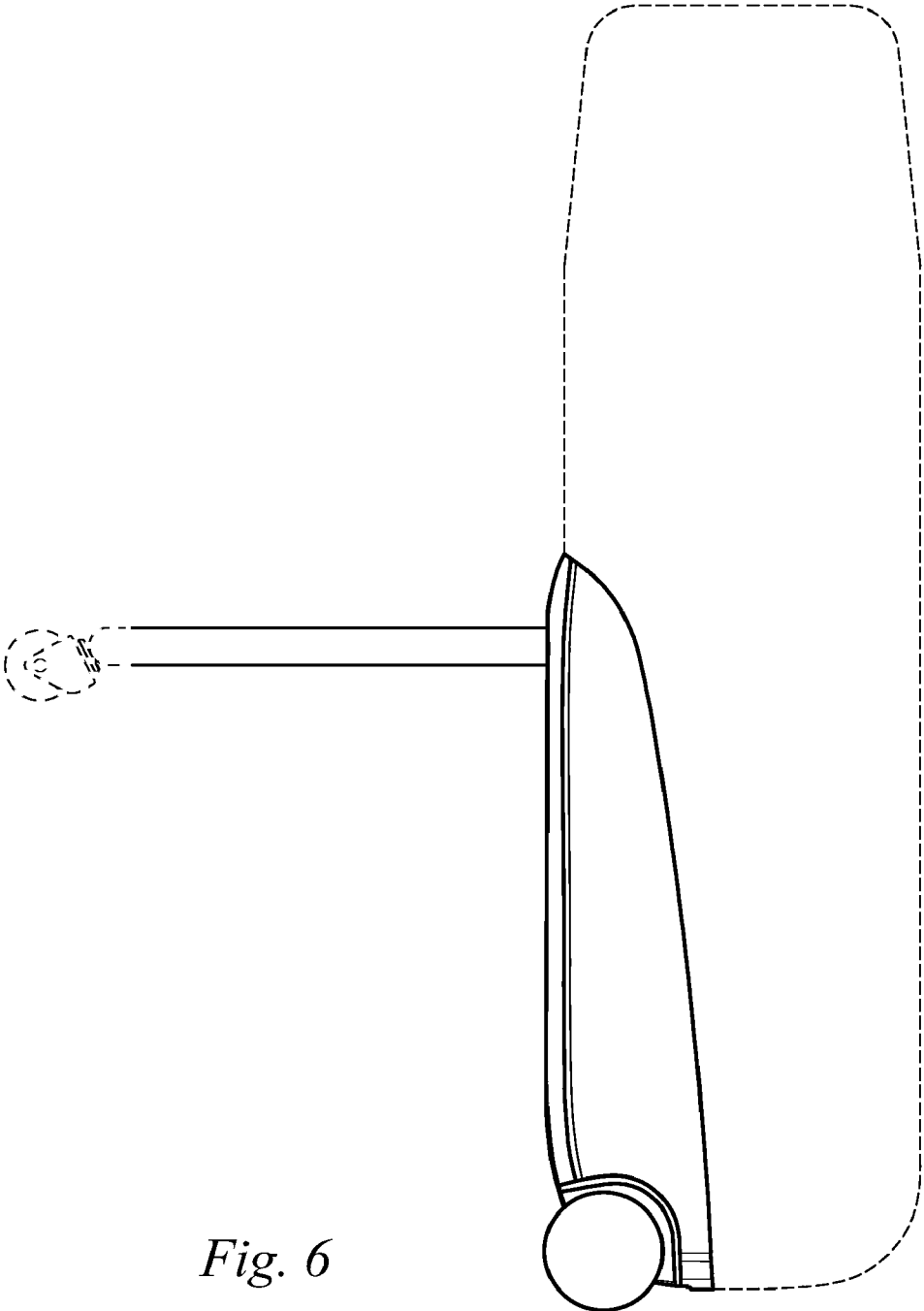

Fig. 6

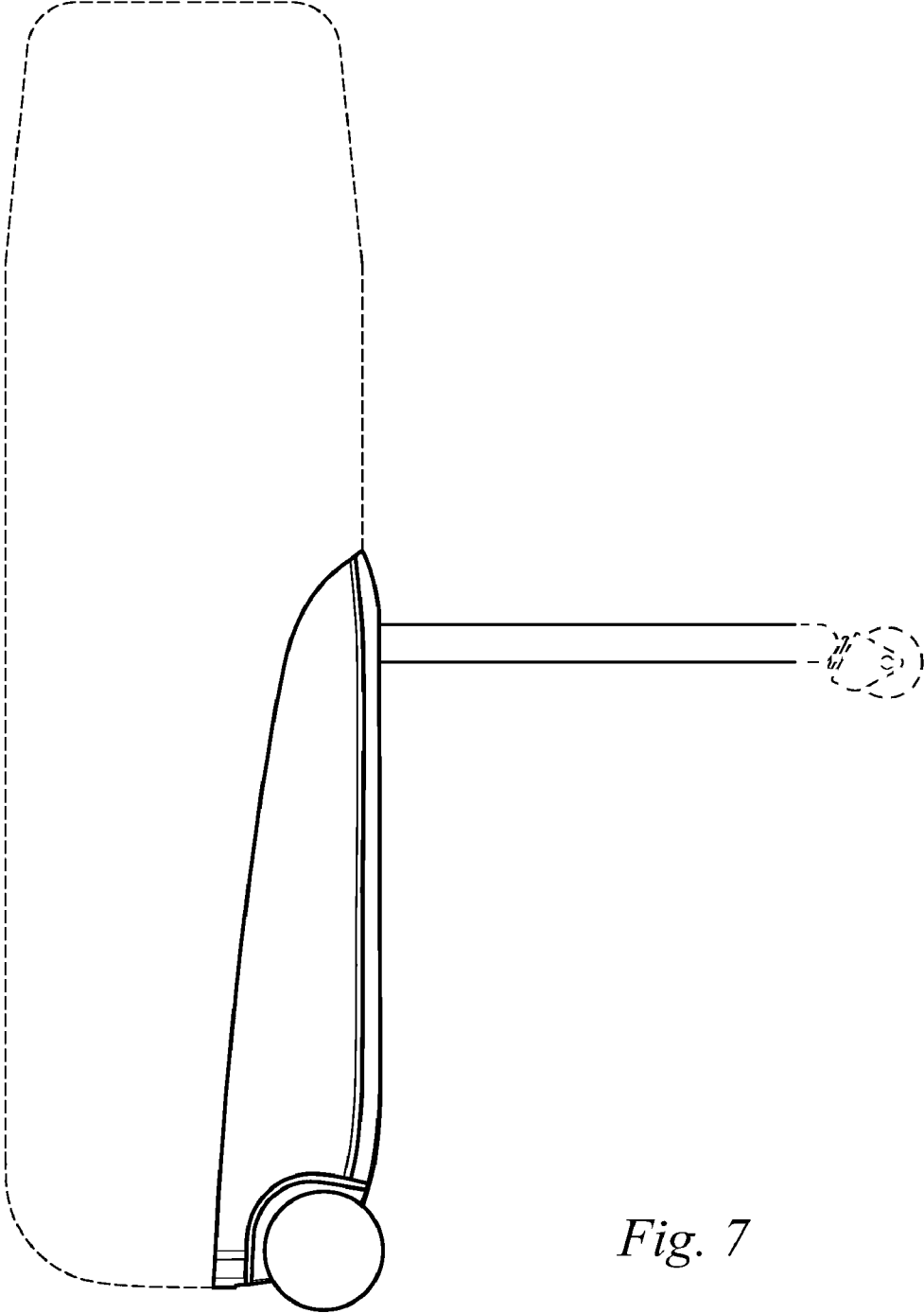

Fig. 7