



US00D610524S

(12) **United States Design Patent**
Villarreal

(10) **Patent No.:** **US D610,524 S**

(45) **Date of Patent:** **** Feb. 23, 2010**

(54) **RACE CAR THEMED CAR TOP CARRIER**

D561,681 S 2/2008 Villarreal

D565,469 S * 4/2008 Young D12/102

(76) Inventor: **Victoria Villarreal**, 610 Blackwater Rd.,
Chillicothe, OH (US) 45601

* cited by examiner

(**) Term: **14 Years**

Primary Examiner—Stacia Cadmus

(21) Appl. No.: **29/343,888**

(74) *Attorney, Agent, or Firm*—Gallagher & Dawsey Co.,
LPA; Michael J. Gallagher; David J. Dawsey

(22) Filed: **Sep. 21, 2009**

(57) **CLAIM**

(51) **LOC (9) Cl.** **12-16**

I claim the ornamental design for a race car themed car top carrier, as shown and described.

(52) **U.S. Cl.** **D12/413**

(58) **Field of Classification Search** D12/406,
D12/412–413, 102; 296/99.1, 37.1, 100.01,
296/100.02, 157; 224/309–310, 314–315,
224/319–320, 323–329, 273; D3/273; 206/315.1–315.4;
D21/433, 533, 424

See application file for complete search history.

DESCRIPTION

FIG. 1 is a front elevation view of a race car themed car top carrier showing my new design;

FIG. 2 is a rear elevation view thereof;

FIG. 3 is a left side elevation view thereof;

FIG. 4 is a right side elevation view thereof;

FIG. 5 is a top plan view thereof; and,

FIG. 6 is a bottom plan view thereof.

The broken lines are for illustrative purposes only and form no part of the claimed design.

(56) **References Cited**

U.S. PATENT DOCUMENTS

D320,183 S *	9/1991	Jacobsson et al.	D12/413
D353,413 S *	12/1994	Hamlin	D21/433
D377,633 S *	1/1997	Hutchins	D12/102
D435,011 S	12/2000	Gruff	
D530,571 S	10/2006	Hemann et al.	
D540,246 S	4/2007	Yang	

1 Claim, 6 Drawing Sheets

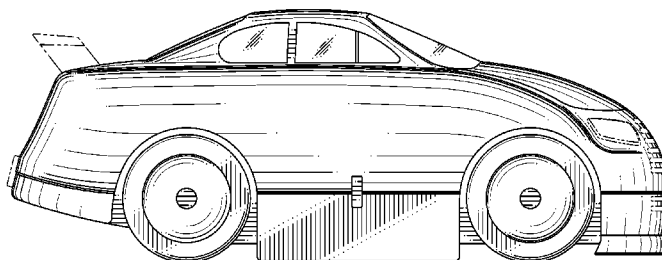
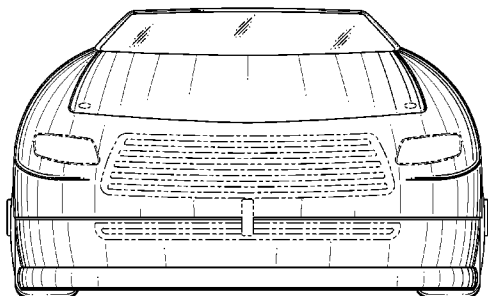

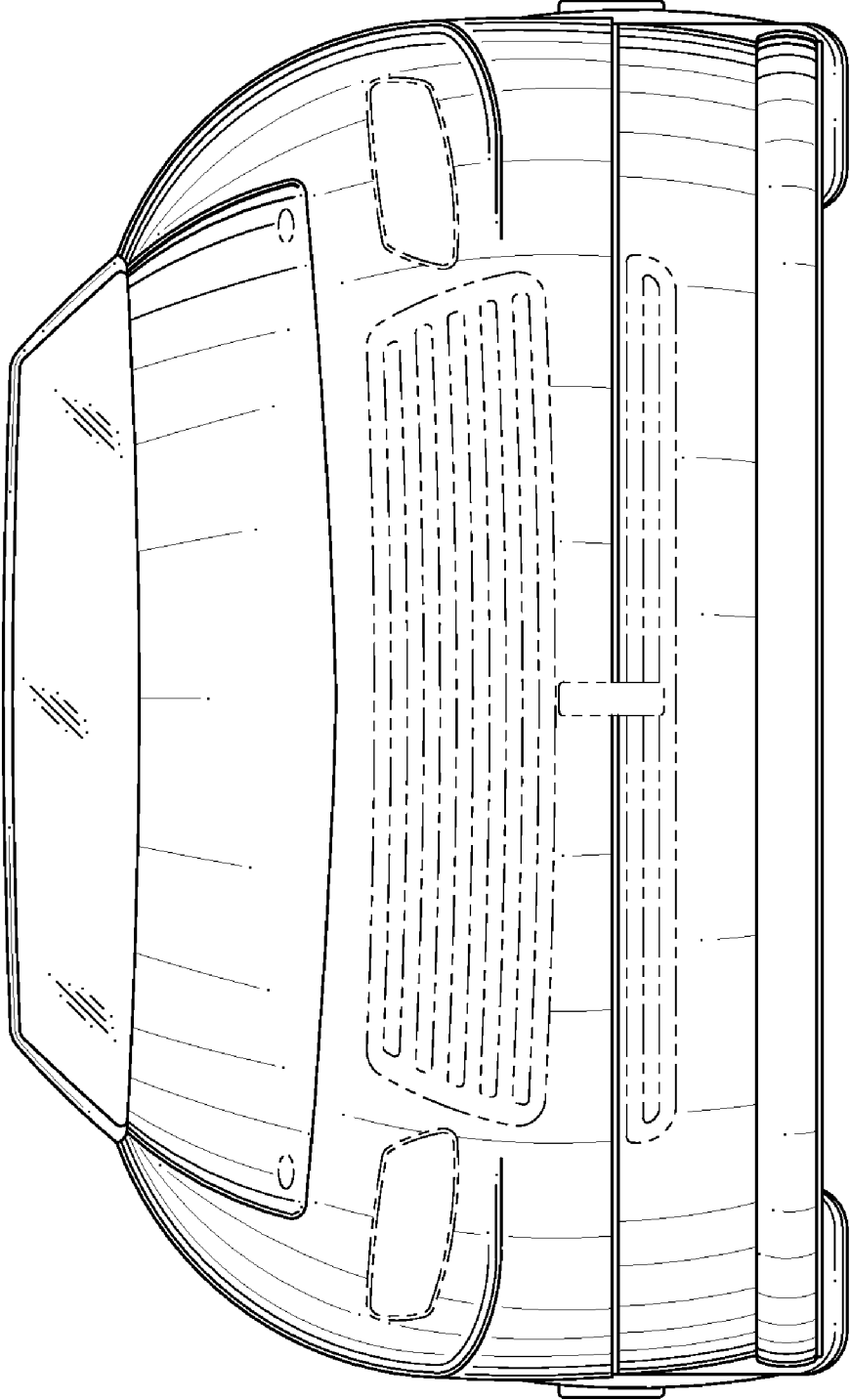

Fig.1

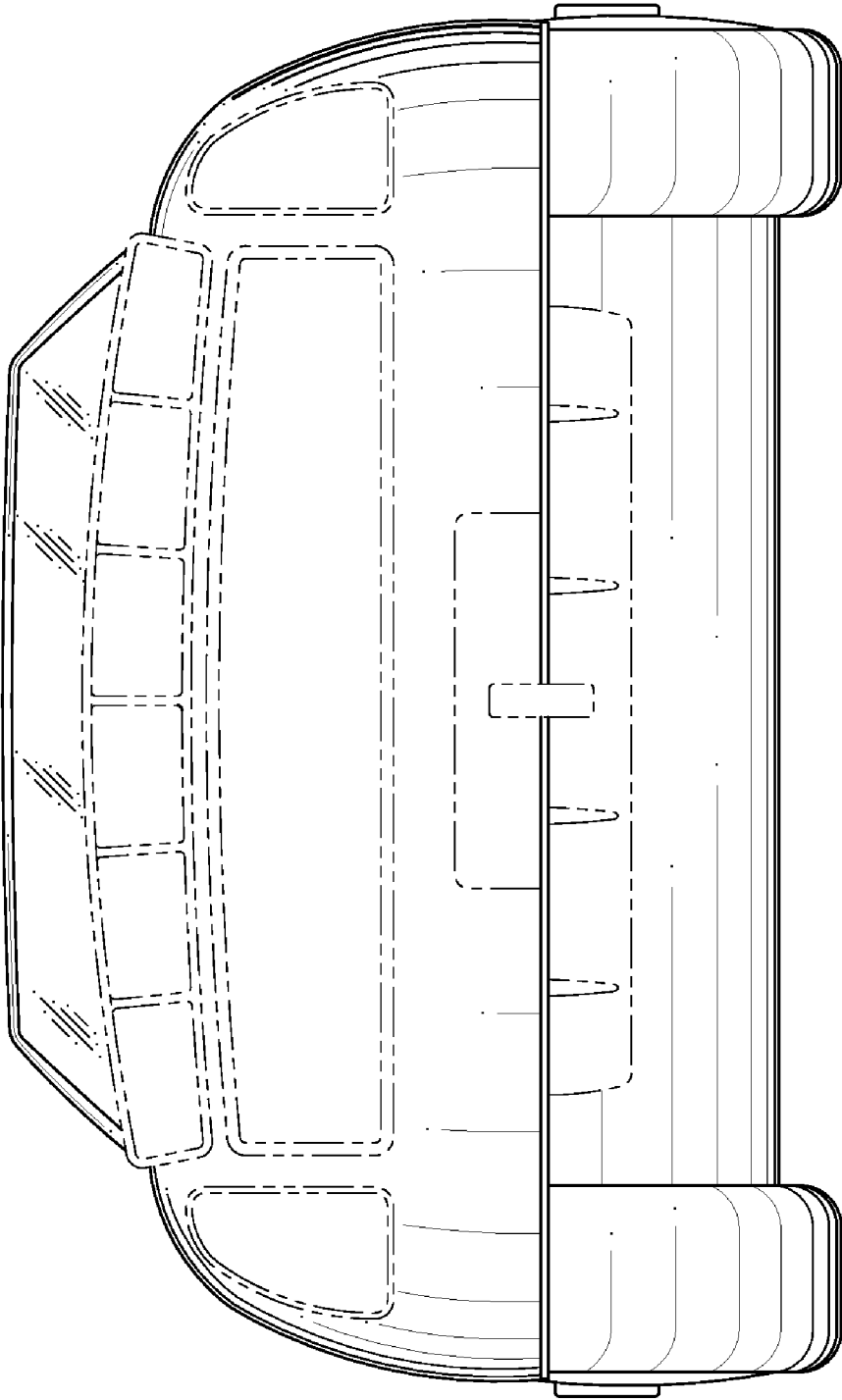

Fig. 2

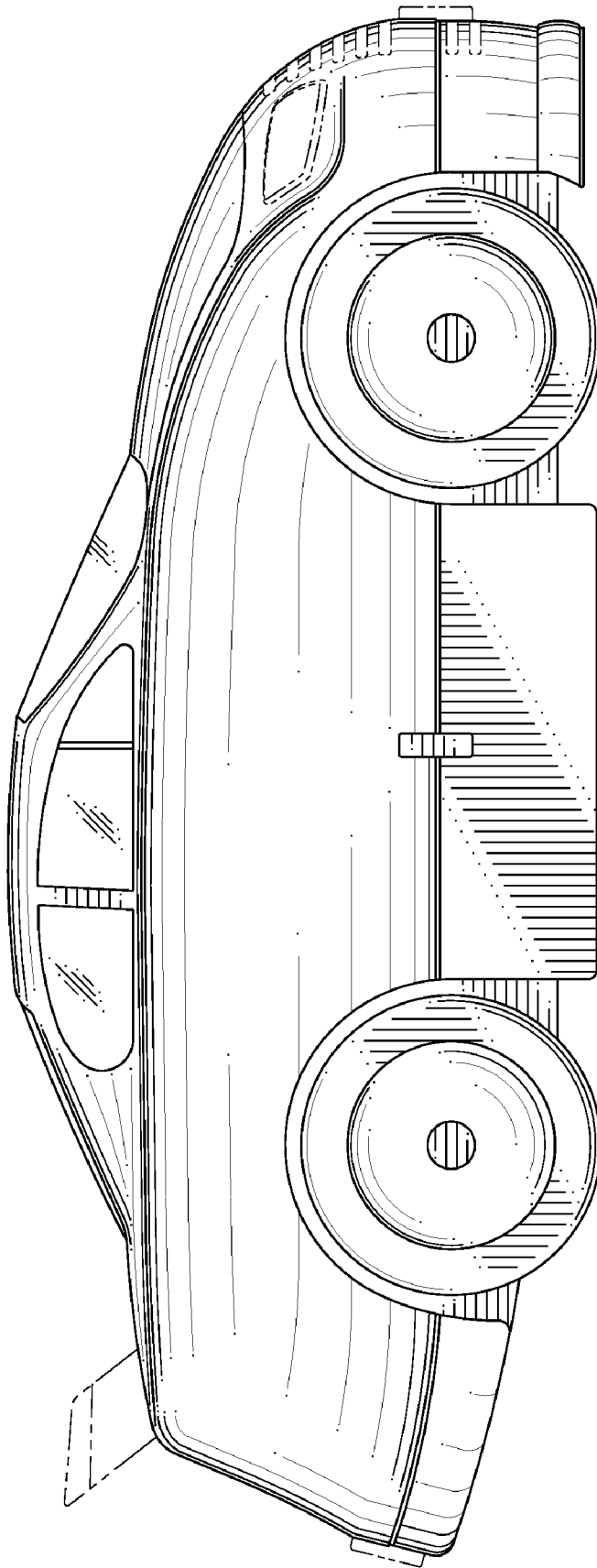

Fig. 3

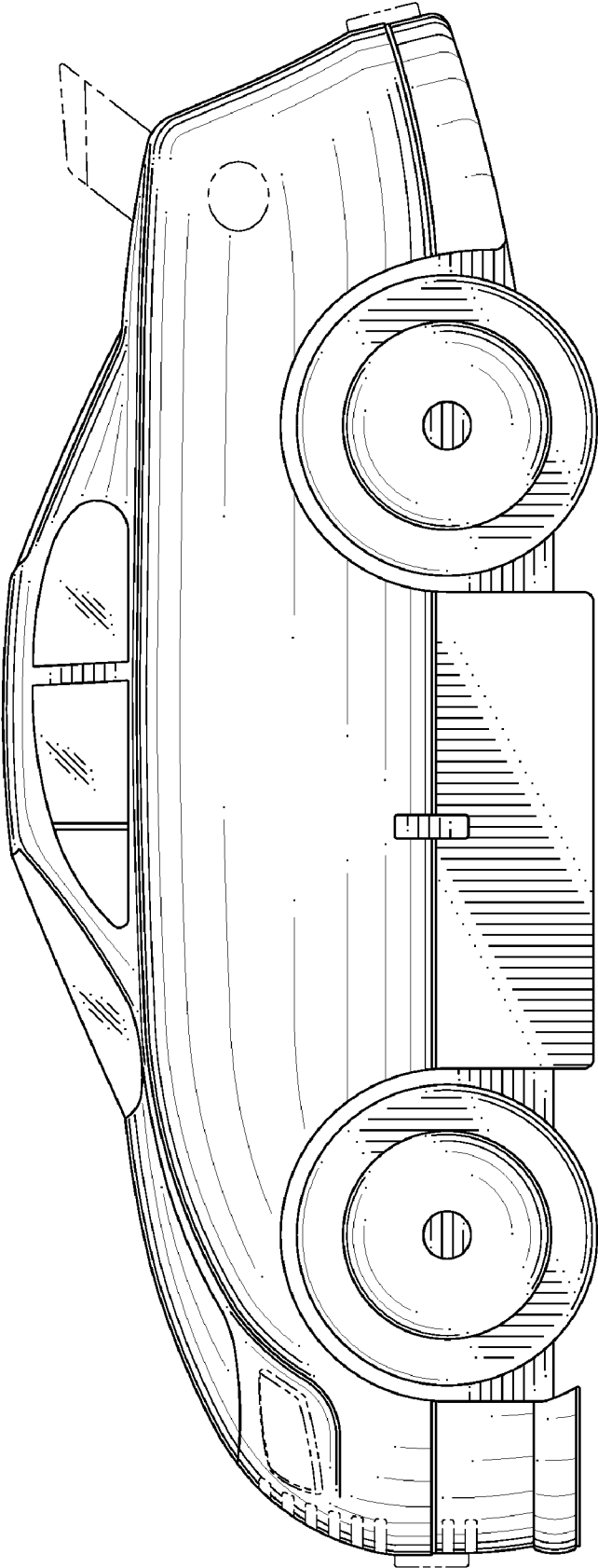

Fig. 4

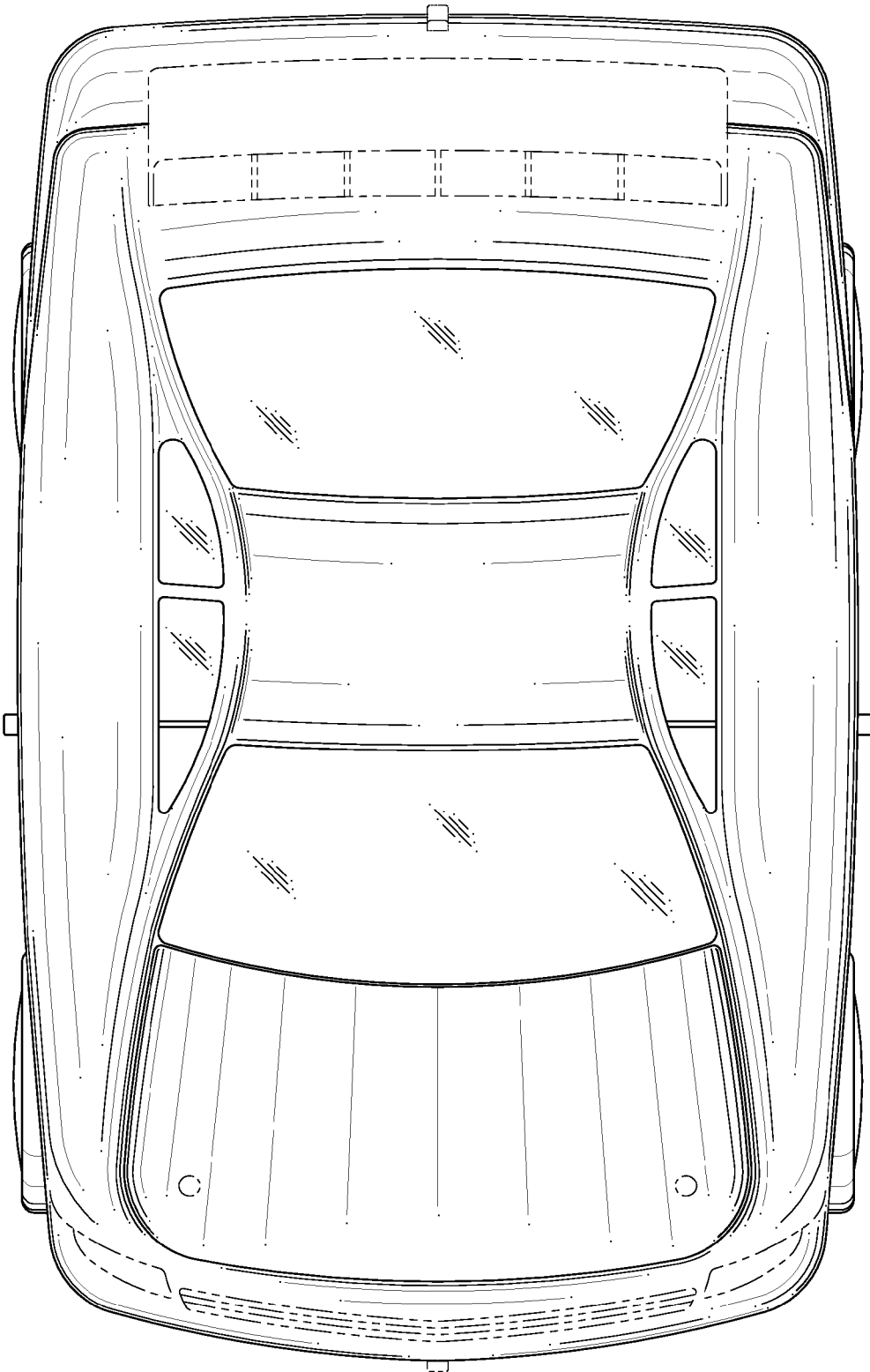

Fig.5

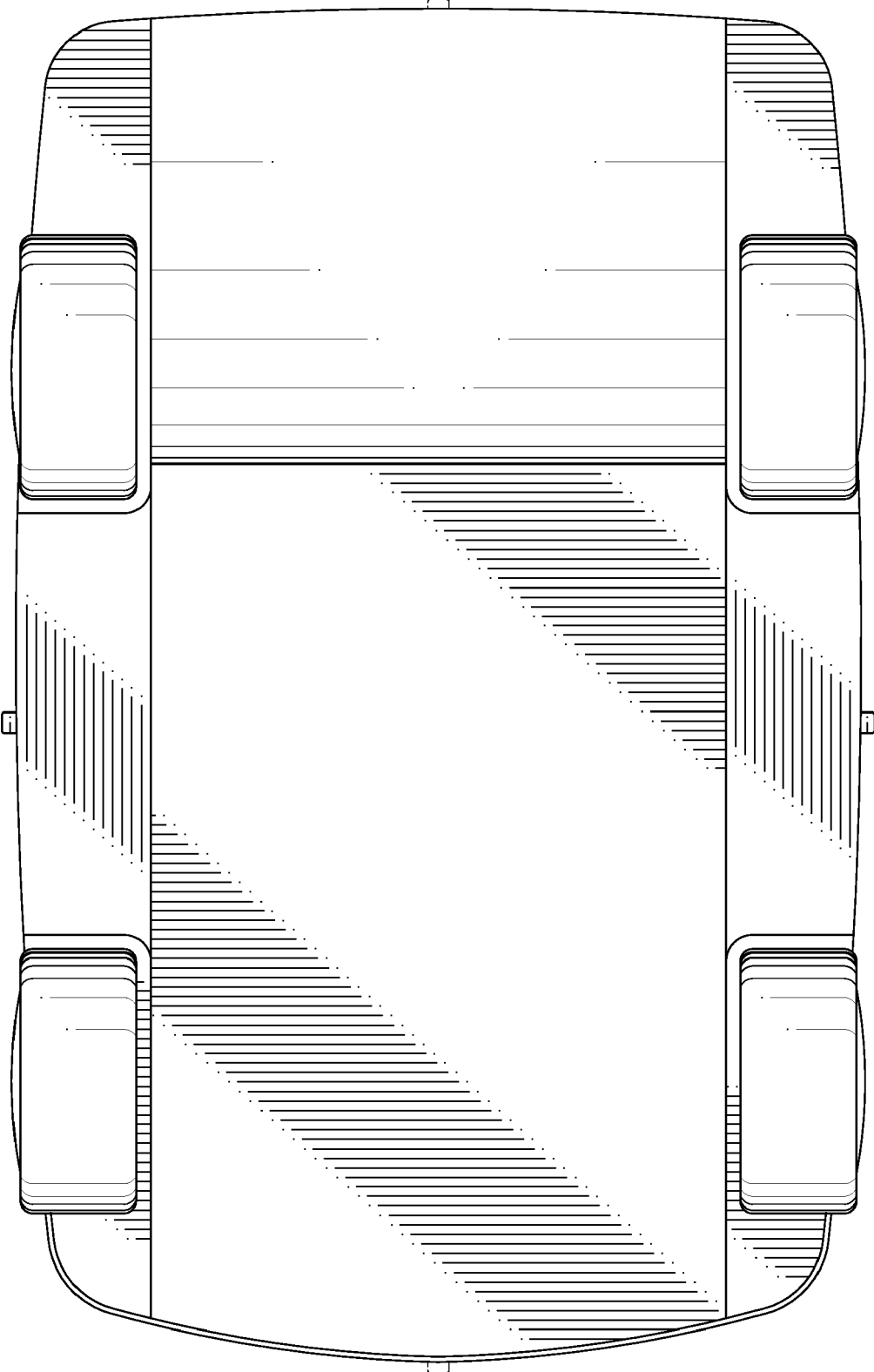

Fig. 6