



US00D714547S

(12) **United States Design Patent**
Enes

(10) **Patent No.:** **US D714,547 S**

(45) **Date of Patent:** **** Oct. 7, 2014**

- (54) **TRAVEL CASE**
- (71) Applicant: **Eric W. Reimers**, Missoula, MT (US)
- (72) Inventor: **Seth McKindra Enes**, Missoula, MT (US)
- (73) Assignee: **Eric W. Reimers**, Missoula, MT (US)
- (**) Term: **14 Years**
- (21) Appl. No.: **29/477,155**

- (22) Filed: **Dec. 19, 2013**
 - (51) **LOC (10) Cl.** **03-01**
 - (52) **U.S. Cl.**
USPC **D3/261**
 - (58) **Field of Classification Search**
USPC D3/261, 216, 221, 904, 315, 254, 255;
206/315.2-315.8; 224/328, 917;
280/814; D12/413
- See application file for complete search history.

(56) **References Cited**

U.S. PATENT DOCUMENTS

D319,346 S *	8/1991	Jessen	D3/255
D339,227 S *	9/1993	Fritze et al.	D3/255
D342,049 S *	12/1993	Harrison	D12/413
5,285,942 A *	2/1994	Wills	224/328
5,415,333 A *	5/1995	Wills	224/328
D362,545 S *	9/1995	Vincent	D3/261
D367,168 S *	2/1996	Vincent	D3/261
D367,169 S *	2/1996	Vincent	D3/261
D370,997 S	6/1996	Hsieh	
5,568,848 A	10/1996	Liang	
D379,016 S	4/1997	Wilson	
D389,643 S *	1/1998	Stratton	D3/254
D394,950 S *	6/1998	Kite	D3/255

5,799,848 A *	9/1998	Wills	224/328
D438,011 S	2/2001	Shick	
6,182,981 B1	2/2001	Kuo	
D473,181 S *	4/2003	Schappach	D12/413
D474,337 S *	5/2003	Boardman et al.	D3/255
D487,543 S	3/2004	Chang	
D497,480 S	10/2004	Drew et al.	
6,869,086 B2	3/2005	Sadow	
D511,043 S	11/2005	Herold	
7,014,020 B2	3/2006	Tamura	
7,188,714 B1	3/2007	Herold	
7,219,902 B1	5/2007	Herold	
D570,601 S	6/2008	Drew et al.	
D587,903 S	3/2009	Sherrell et al.	
D587,904 S	3/2009	Sherrell et al.	
2004/0216970 A1	11/2004	Sherrell et al.	
2006/0237108 A1	10/2006	Herold	

* cited by examiner

Primary Examiner — Deanna L Pratt

Assistant Examiner — Lilyana Bekic

(74) *Attorney, Agent, or Firm* — David J. Dawsey; Michael J. Gallagher; Gallagher & Dawsey Co., LPA

(57) **CLAIM**

I claim the ornamental design for a travel case, as shown and described.

DESCRIPTION

FIG. 1 is an isometric view of a travel case showing the new design;
 FIG. 2 is a top plan view thereof;
 FIG. 3 is a bottom plan view thereof;
 FIG. 4 is a left side elevation view thereof;
 FIG. 5 is a right side elevation view thereof;
 FIG. 6 is a front elevation view thereof; and,
 FIG. 7 is a rear elevation view thereof.

1 Claim, 4 Drawing Sheets

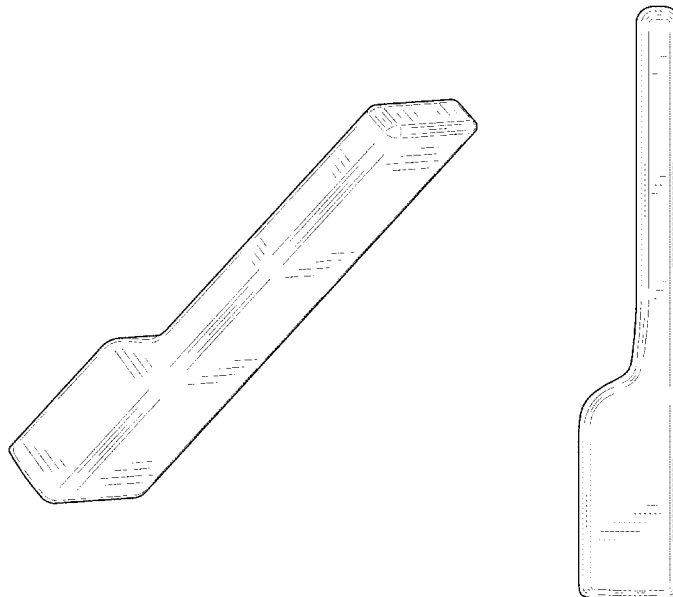

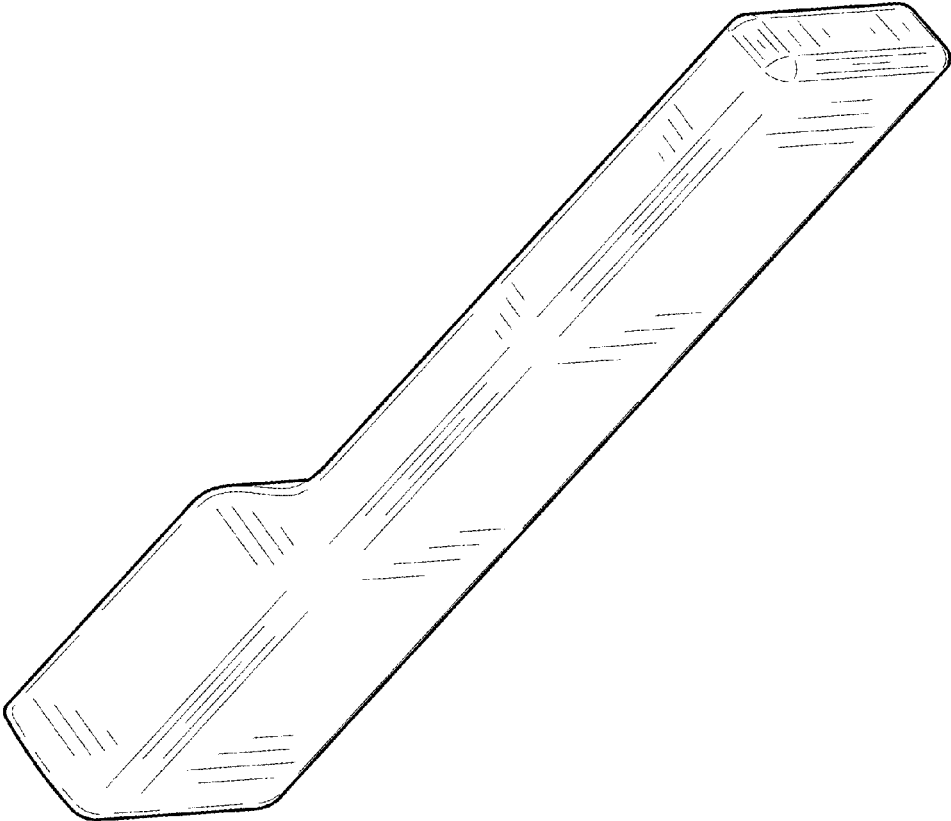

Fig. 1

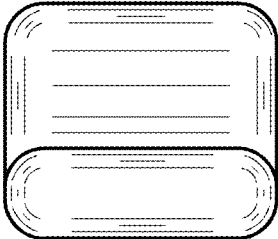

Fig. 2

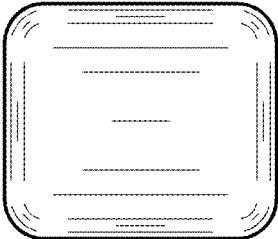

Fig. 3

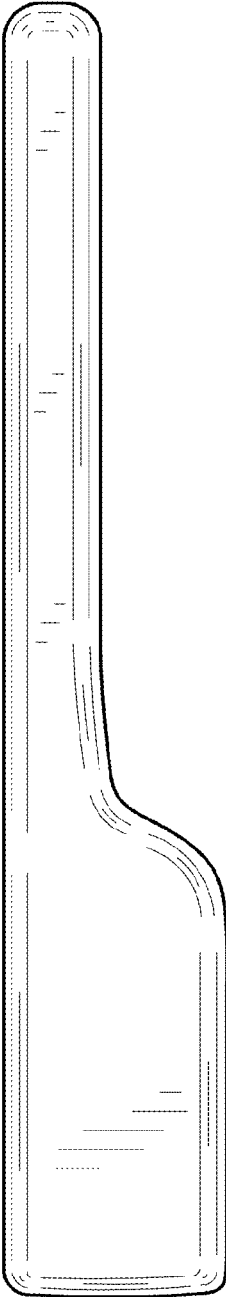

Fig. 4

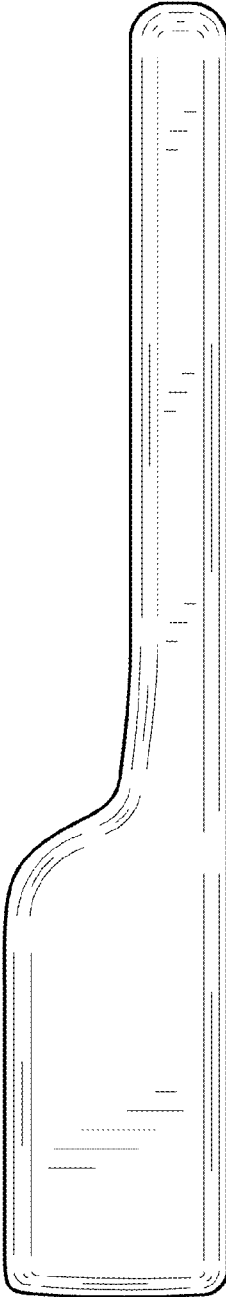

Fig. 5

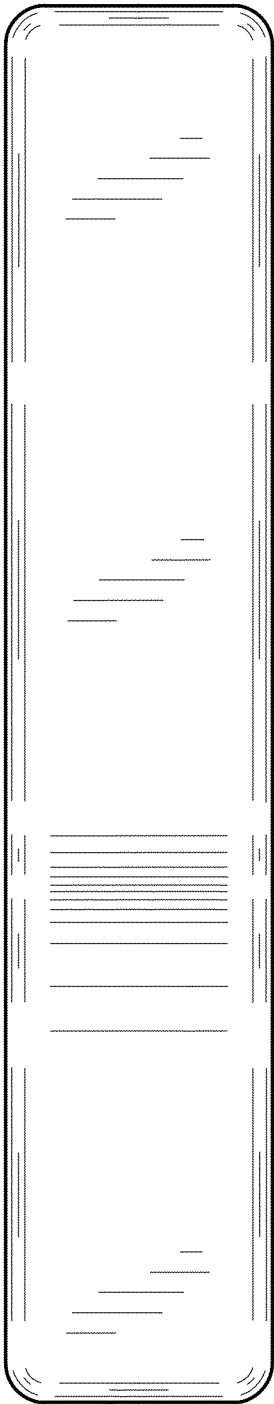

Fig. 6

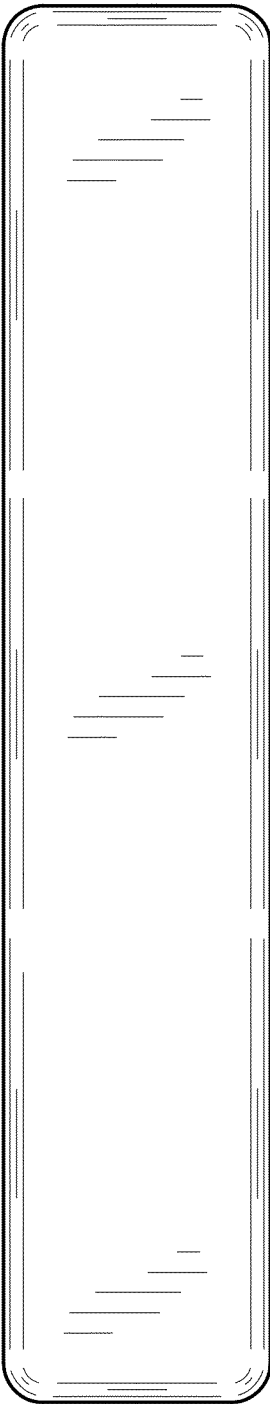

Fig. 7