



US011351425B2

(12) **United States Patent**
Albertsen et al.

(10) **Patent No.:** **US 11,351,425 B2**

(45) **Date of Patent:** **Jun. 7, 2022**

(54) **MULTI-MATERIAL IRON-TYPE GOLF CLUB HEAD**

(71) Applicant: **Taylor Made Golf Company, Inc.**,
Carlsbad, CA (US)

(72) Inventors: **Jeffrey J. Albertsen**, Plano, TX (US);
Michael Scott Burnett, McKinney, TX (US)

(73) Assignee: **TAYLOR MADE GOLF COMPANY, INC.**,
Carlsbad, CA (US)

(*) Notice: Subject to any disclaimer, the term of this
patent is extended or adjusted under 35
U.S.C. 154(b) by 0 days.

(21) Appl. No.: **17/101,021**

(22) Filed: **Nov. 23, 2020**

(65) **Prior Publication Data**
US 2021/0069559 A1 Mar. 11, 2021

Related U.S. Application Data

(63) Continuation of application No. 16/422,819, filed on
May 24, 2019, now Pat. No. 10,843,050, which is a
continuation of application No. 15/955,775, filed on
Apr. 18, 2018, now Pat. No. 10,300,350, which is a
continuation of application No. 15/389,505, filed on
Dec. 23, 2016, now Pat. No. 9,950,222, which is a
continuation of application No. 14/873,477, filed on
Oct. 2, 2015, now Pat. No. 9,566,479, which is a
continuation of application No. 14/256,005, filed on
Apr. 18, 2014, now Pat. No. 9,168,428, which is a
continuation of application No. 13/949,586, filed on
Jul. 24, 2013, now Pat. No. 8,721,471, which is a
(Continued)

(51) **Int. Cl.**
A63B 53/04 (2015.01)
A63B 60/00 (2015.01)

(52) **U.S. Cl.**
CPC *A63B 53/0466* (2013.01); *A63B 53/04*
(2013.01); *A63B 53/047* (2013.01); *A63B*
60/00 (2015.10); *A63B 53/0408* (2020.08);
A63B 53/0412 (2020.08); *A63B 53/0433*
(2020.08); *A63B 53/0437* (2020.08); *A63B*
53/0458 (2020.08)

(58) **Field of Classification Search**
CPC A63B 53/04; A63B 53/0408
USPC 473/324–350
See application file for complete search history.

(56) **References Cited**

U.S. PATENT DOCUMENTS

411,000 A 9/1889 Anderson
708,575 A 9/1902 Mules
(Continued)

FOREIGN PATENT DOCUMENTS

CN 2436182 Y 6/2001
CN 201353407 Y 12/2009
(Continued)

OTHER PUBLICATIONS

Mike Stachura, "The Hot List", Golf Digest Magazine, Feb. 2004,
pp. 82-86.

(Continued)

Primary Examiner — Alvin A Hunter
(74) *Attorney, Agent, or Firm* — Dawsey Co., LPA;
David J. Dawsey

(57) **ABSTRACT**

A multi-material iron-type golf club head having a shell that
defines a closed internal volume, where the head is com-
posed of at least two different materials, incorporates a
variable face thickness, and achieves a high characteristic
time.

20 Claims, 24 Drawing Sheets

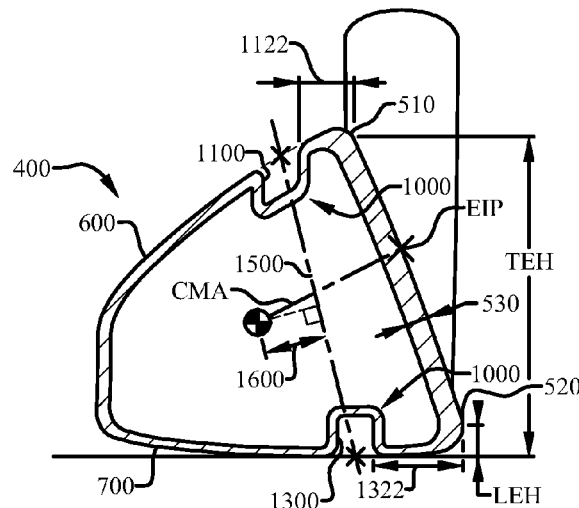

Related U.S. Application Data

continuation of application No. 13/543,921, filed on Jul. 9, 2012, now Pat. No. 8,517,860, which is a continuation of application No. 13/324,093, filed on Dec. 13, 2011, now Pat. No. 8,241,143, which is a continuation of application No. 12/791,025, filed on Jun. 1, 2010, now Pat. No. 8,235,844.

(56)

References Cited

U.S. PATENT DOCUMENTS

727,819	A	5/1903	Mattern	D256,709	S	9/1980	Reid, Jr. et al.
819,900	A	5/1906	Martin	4,247,105	A	1/1981	Jeghers
1,133,129	A	3/1915	Govan	4,262,562	A	4/1981	MacNeill
1,518,316	A	12/1924	Ellingham	D259,698	S	6/1981	MacNeill
1,526,438	A	2/1925	Scott	4,322,083	A	3/1982	Imai
1,538,312	A	5/1925	Beat	4,340,229	A	7/1982	Stuff, Jr.
1,592,463	A	7/1926	Marker	4,398,965	A	8/1983	Campau
1,658,581	A	2/1928	Tobia	4,411,430	A	10/1983	Dian
1,704,119	A	3/1929	Buhrke	4,423,874	A	1/1984	Stuff, Jr.
1,705,997	A	3/1929	Williams	4,431,192	A	2/1984	Stuff, Jr.
1,970,409	A	8/1934	Wiedemann	4,432,549	A	2/1984	Zebelean
2,004,968	A	6/1935	Young	4,438,931	A	3/1984	Motomiya
2,034,936	A	3/1936	Barnhart	4,471,961	A	9/1984	Masghati et al.
2,041,676	A	5/1936	Gallagher	4,489,945	A	12/1984	Kobayashi
D107,007	S	11/1937	Cashmore	4,527,799	A	7/1985	Solheim
2,198,981	A	4/1940	Sullivan	4,530,505	A	7/1985	Stuff
2,214,356	A	9/1940	Wettlaufer	D284,346	S	6/1986	Masters
2,225,930	A	12/1940	Sexton	4,592,552	A	6/1986	Garber
2,328,583	A	9/1943	Reach	4,602,787	A	7/1986	Sugioka et al.
2,332,342	A	10/1943	Reach	4,607,846	A	8/1986	Perkins
2,360,364	A	10/1944	Reach	D285,473	S	9/1986	Flood
2,375,249	A	5/1945	Richer	4,712,798	A	12/1987	Preato
2,460,435	A	2/1949	Schaffer	4,730,830	A	3/1988	Tilley
2,681,523	A	6/1954	Sellers	4,736,093	A	4/1988	Braly
2,968,486	A	1/1961	Jackson	4,754,974	A	7/1988	Kobayashi
3,064,980	A	11/1962	Steiner	4,754,977	A	7/1988	Sahm
3,084,940	A	4/1963	Cissel	4,762,322	A	8/1988	Molitor et al.
3,085,804	A	4/1963	Pieper	4,787,636	A	11/1988	Honma
3,166,320	A	1/1965	Onions	4,795,159	A	1/1989	Nagamoto
3,466,047	A	9/1969	Rodia et al.	4,803,023	A	2/1989	Enomoto et al.
3,486,755	A	12/1969	Hodge	4,809,983	A	3/1989	Langert
3,556,533	A	1/1971	Hollis	4,852,880	A	8/1989	Kobayashi
3,589,731	A	6/1971	Chancellor	4,867,457	A	9/1989	Lowe
3,606,327	A	9/1971	Gorman	4,867,458	A	9/1989	Sumikawa et al.
3,610,630	A	10/1971	Glover	4,869,507	A	9/1989	Sahm
3,652,094	A	3/1972	Glover	4,881,739	A	11/1989	Garcia
3,672,419	A	6/1972	Fischer	4,890,840	A	1/1990	Kobayashi
3,692,306	A	9/1972	Glover	4,895,367	A	1/1990	Kajita et al.
3,743,297	A	7/1973	Dennis	4,895,371	A	1/1990	Bushner
3,860,244	A	1/1975	Cosby	4,915,558	A	4/1990	Muller
3,893,672	A	7/1975	Schonher	4,919,428	A	4/1990	Perkins
3,897,066	A	7/1975	Belmont	D307,783	S	5/1990	Iinuma
3,961,796	A	6/1976	Thompson	4,962,932	A	10/1990	Anderson
3,970,236	A	7/1976	Rogers	4,994,515	A	2/1991	Washiyama et al.
3,976,299	A	8/1976	Lawrence et al.	5,006,023	A	4/1991	Kaplan
3,979,122	A	9/1976	Belmont	5,020,950	A	6/1991	Ladouceur
3,979,123	A	9/1976	Belmont	5,028,049	A	7/1991	McKeighen
3,985,363	A	10/1976	Jepson et al.	5,039,267	A	8/1991	Wollar
3,997,170	A	12/1976	Goldberg	5,042,806	A	8/1991	Helmstetter
4,008,896	A	2/1977	Gordos	5,050,879	A	9/1991	Sun et al.
4,027,885	A	6/1977	Rogers	5,058,895	A	10/1991	Igarashi
4,043,563	A	8/1977	Churchward	5,076,585	A	12/1991	Bouquet
4,052,075	A	10/1977	Daly	D323,035	S	1/1992	Yang
4,065,133	A	12/1977	Gordos	5,078,400	A	1/1992	Desbiolles et al.
4,076,254	A	2/1978	Nygren	5,092,599	A	3/1992	Okumoto et al.
4,077,633	A	3/1978	Studen	5,116,054	A	5/1992	Johnson
4,085,934	A	4/1978	Churchward	5,121,922	A	6/1992	Harsh, Sr.
4,121,832	A	10/1978	Ebbing	5,122,020	A	6/1992	Bedi
4,139,196	A	2/1979	Riley	5,172,913	A	12/1992	Bouquet
4,147,349	A	4/1979	Jeghers	5,190,289	A	3/1993	Nagai et al.
4,150,702	A	4/1979	Holmes	5,193,810	A	3/1993	Antonious
4,165,076	A	8/1979	Celia	5,203,565	A	4/1993	Murray et al.
4,189,976	A	2/1980	Becker	5,221,086	A	6/1993	Antonious
4,193,601	A	3/1980	Reid, Jr. et al.	5,232,224	A	8/1993	Zeider
4,214,754	A	7/1980	Zebelean	5,244,210	A	9/1993	Au
				5,251,901	A	10/1993	Solheim et al.
				5,253,869	A	10/1993	Dingle et al.
				5,255,919	A	10/1993	Johnson
				D343,558	S	1/1994	Latraverse et al.
				5,297,794	A	3/1994	Lu
				5,301,944	A	4/1994	Koehler
				5,306,008	A	4/1994	Kinoshita
				5,312,106	A	5/1994	Cook
				5,316,305	A	5/1994	McCabe
				5,318,297	A	6/1994	Davis et al.
				5,320,005	A	6/1994	Hsiao
				5,328,176	A	7/1994	Lo
				5,340,106	A	8/1994	Ravaris
				5,346,216	A	9/1994	Aizawa

(56)

References Cited

U.S. PATENT DOCUMENTS

5,346,217 A	9/1994	Tsuchiya et al.	5,785,609 A	7/1998	Sheets et al.
D351,441 S	10/1994	Iinuma et al.	5,788,587 A	8/1998	Tseng
5,385,348 A	1/1995	Wargo	5,797,807 A	8/1998	Moore
5,395,113 A	3/1995	Antonious	5,798,587 A	8/1998	Lee
D357,290 S	4/1995	Viollaz et al.	D397,750 S	9/1998	Frazetta
5,410,798 A	5/1995	Lo	RE35,955 E	11/1998	Lu
5,419,556 A	5/1995	Take	5,830,084 A	11/1998	Kosmatka
5,421,577 A	6/1995	Kobayashi	5,833,551 A	11/1998	Vincent et al.
5,429,365 A	7/1995	McKeighen	D402,726 S	12/1998	McCabe et al.
5,437,456 A	8/1995	Schmidt et al.	D403,037 S	12/1998	Stone et al.
5,439,222 A	8/1995	Kranenberg	5,851,160 A	12/1998	Rugge et al.
5,439,223 A	8/1995	Kobayashi	D405,488 S	2/1999	Burrows
5,441,274 A	8/1995	Clay	5,876,293 A	3/1999	Musty
5,447,309 A	9/1995	Vincent	5,885,166 A	3/1999	Shiraishi
5,449,260 A	9/1995	Whittle	5,890,971 A	4/1999	Shiraishi
D363,750 S	10/1995	Reed	D409,463 S	5/1999	McMullin
D365,615 S	12/1995	Shimatani	5,908,356 A	6/1999	Nagamoto
D366,508 S	1/1996	Hutin	5,911,638 A	6/1999	Parente et al.
5,482,280 A	1/1996	Yamawaki	5,913,735 A	6/1999	Kenmi
5,484,155 A	1/1996	Yamawaki et al.	5,916,042 A	6/1999	Reimers
5,492,327 A	2/1996	Biafore, Jr.	D412,547 S	8/1999	Fong
5,511,786 A	4/1996	Antonious	5,935,019 A	8/1999	Yamamoto
5,518,243 A	5/1996	Redman	5,935,020 A	8/1999	Stites et al.
5,533,730 A	7/1996	Ruvang	5,941,782 A	8/1999	Cook
D372,512 S	8/1996	Simmons	D413,952 S	9/1999	Oyer
5,544,884 A	8/1996	Hardman	5,947,840 A	9/1999	Ryan
5,547,188 A	8/1996	Dumontier et al.	5,954,595 A	9/1999	Antonious
5,558,332 A	9/1996	Cook	5,967,905 A	10/1999	Nakahara et al.
D375,130 S	10/1996	Hlinka et al.	5,971,867 A	10/1999	Galy
5,564,705 A	10/1996	Kobayashi et al.	5,976,033 A	11/1999	Takeda
5,571,053 A	11/1996	Lane	5,997,415 A	12/1999	Wood
5,573,467 A	11/1996	Chou et al.	6,001,029 A	12/1999	Kobayashi
5,575,723 A	11/1996	Take et al.	6,007,433 A	12/1999	Helmstetter et al.
5,582,553 A	12/1996	Ashcraft et al.	6,015,354 A	1/2000	Ahn et al.
5,584,770 A	12/1996	Jensen	6,017,177 A	1/2000	Lanham
D377,509 S	1/1997	Katayama	6,019,686 A	2/2000	Gray
5,599,243 A	2/1997	Kobayashi	6,023,891 A	2/2000	Robertson et al.
5,613,917 A	3/1997	Kobayashi et al.	6,027,415 A	2/2000	Takeda
D378,770 S	4/1997	Hlinka et al.	6,032,677 A	3/2000	Blechman et al.
5,616,088 A	4/1997	Aizawa et al.	6,033,318 A	3/2000	Drajan, Jr. et al.
5,620,379 A	4/1997	Borys	6,033,319 A	3/2000	Farrar
5,624,331 A	4/1997	Lo et al.	6,033,321 A	3/2000	Yamamoto
5,629,475 A	5/1997	Chastonay	6,042,486 A	3/2000	Gallagher
5,632,694 A	5/1997	Lee	6,048,278 A	4/2000	Meyer et al.
5,632,695 A	5/1997	Hlinka et al.	6,056,649 A	5/2000	Imai
5,645,495 A	7/1997	Saso	6,062,988 A	5/2000	Yamamoto
D382,612 S	8/1997	Oyer	6,074,308 A	6/2000	Domas
5,658,206 A	8/1997	Antonious	6,077,171 A	6/2000	Yoneyama
5,669,826 A	9/1997	Chang et al.	6,080,068 A *	6/2000	Takeda A63B 53/047 473/305
5,669,827 A	9/1997	Nagamoto	6,080,069 A	6/2000	Long
5,681,228 A	10/1997	Mikame et al.	6,083,115 A	7/2000	King
5,683,309 A	11/1997	Reimers	6,086,485 A	7/2000	Hamada et al.
5,688,189 A	11/1997	Bland	6,089,994 A	7/2000	Sun
5,695,412 A	12/1997	Cook	6,093,113 A	7/2000	Mertens
5,700,208 A	12/1997	Nelms	6,123,627 A	9/2000	Antonious
5,709,613 A	1/1998	Sheraw	6,139,445 A	10/2000	Werner et al.
5,718,641 A	2/1998	Lin	6,146,286 A	11/2000	Masuda
5,720,674 A	2/1998	Galy	6,149,533 A	11/2000	Finn
D392,354 S	3/1998	Burrows	6,162,132 A	12/2000	Yoneyama
D392,526 S	3/1998	Nicely	6,162,133 A	12/2000	Peterson
5,735,754 A	4/1998	Antonious	6,168,537 B1	1/2001	Ezawa
D394,688 S	5/1998	Fox	6,171,204 B1	1/2001	Stary
5,746,664 A	5/1998	Reynolds, Jr.	6,186,905 B1	2/2001	Kosmatka
5,749,795 A *	5/1998	Schmidt A63B 60/00 473/350	6,190,267 B1	2/2001	Marlowe et al.
5,755,627 A	5/1998	Yamazaki et al.	6,193,614 B1	2/2001	Sasamoto et al.
5,759,114 A	6/1998	Bluto et al.	6,203,448 B1	3/2001	Yamamoto
5,762,567 A	6/1998	Antonious	6,206,789 B1	3/2001	Takeda
5,766,091 A	6/1998	Humphrey et al.	6,206,790 B1	3/2001	Kubica et al.
5,766,095 A	6/1998	Antonious	6,210,290 B1	4/2001	Erickson et al.
5,769,737 A	6/1998	Holladay et al.	6,217,461 B1	4/2001	Galy
5,772,527 A	6/1998	Liu	6,238,303 B1	5/2001	Fite
5,776,010 A	7/1998	Helmstetter et al.	6,244,974 B1	6/2001	Hanberry, Jr.
5,776,011 A	7/1998	Su et al.	6,244,976 B1	6/2001	Murphy et al.
5,785,608 A	7/1998	Collins	6,248,025 B1	6/2001	Murphey et al.
			6,254,494 B1	7/2001	Hasebe et al.
			6,264,414 B1	7/2001	Hartmann et al.
			6,270,422 B1	8/2001	Fisher
			6,277,032 B1	8/2001	Smith

(56)

References Cited

U.S. PATENT DOCUMENTS

6,290,609 B1	9/2001	Takeda	6,612,938 B2	9/2003	Murphy et al.
6,296,579 B1	10/2001	Robinson	6,616,547 B2	9/2003	Vincent et al.
6,299,547 B1	10/2001	Kosmatka	6,620,055 B2	9/2003	Saso
6,306,048 B1	10/2001	McCabe et al.	6,620,056 B2	9/2003	Galloway et al.
6,319,149 B1	11/2001	Lee	6,638,180 B2	10/2003	Tsurumaki
6,319,150 B1	11/2001	Werner et al.	6,638,183 B2	10/2003	Takeda
6,325,728 B1	12/2001	Helmstetter et al.	D482,089 S	11/2003	Burrows
6,332,847 B2	12/2001	Murphy et al.	D482,090 S	11/2003	Burrows
6,334,817 B1	1/2002	Ezawa et al.	D482,420 S	11/2003	Burrows
6,334,818 B1	1/2002	Cameron et al.	6,641,487 B1	11/2003	Hamburger
6,338,683 B1	1/2002	Kosmatka	6,641,490 B2	11/2003	Ellemor
6,340,337 B2	1/2002	Hasebe et al.	6,648,772 B2	11/2003	Vincent et al.
6,344,000 B1	2/2002	Hamada et al.	6,648,773 B1	11/2003	Evans
6,344,001 B1	2/2002	Hamada et al.	6,652,387 B2	11/2003	Liberatore
6,344,002 B1	2/2002	Kajita	D484,208 S	12/2003	Burrows
6,348,012 B1	2/2002	Erickson et al.	6,663,504 B2	12/2003	Hocknell et al.
6,348,013 B1*	2/2002	Kosmatka	6,663,506 B2	12/2003	Nishimoto et al.
		A63B 53/0466	6,669,571 B1	12/2003	Cameron et al.
		473/329	6,669,576 B1	12/2003	Rice
			6,669,577 B1	12/2003	Hocknell et al.
			6,669,578 B1	12/2003	Evans
6,348,014 B1	2/2002	Chiu	6,669,580 B1	12/2003	Cackett et al.
6,354,962 B1	3/2002	Galloway et al.	6,676,536 B1	1/2004	Jacobson
6,364,788 B1	4/2002	Helmstetter et al.	6,679,786 B2	1/2004	McCabe
6,368,232 B1	4/2002	Hamada et al.	D486,542 S	2/2004	Burrows
6,368,234 B1	4/2002	Galloway	6,695,712 B1	2/2004	Iwata et al.
6,371,868 B1	4/2002	Galloway et al.	6,716,111 B2	4/2004	Liberatore
6,379,264 B1	4/2002	Forzano	6,716,114 B2	4/2004	Nishio
6,379,265 B1	4/2002	Hirakawa et al.	6,719,510 B2	4/2004	Cobzaru
6,383,090 B1	5/2002	Odoherly et al.	6,719,641 B2	4/2004	Dabbs et al.
6,386,987 B1	5/2002	Lejeune, Jr.	6,719,645 B2	4/2004	Kouno
6,386,990 B1	5/2002	Reyes et al.	6,723,002 B1	4/2004	Barlow
6,390,933 B1	5/2002	Galloway et al.	6,739,982 B2	5/2004	Murphy et al.
6,398,666 B1	6/2002	Evans et al.	6,739,983 B2	5/2004	Helmstetter et al.
6,406,378 B1	6/2002	Murphy et al.	6,743,118 B1	6/2004	Soracco
6,409,612 B1	6/2002	Evans et al.	6,749,523 B1	6/2004	Forzano
6,425,832 B2	7/2002	Cackett et al.	6,757,572 B1	6/2004	Forest
6,434,811 B1	8/2002	Helmstetter et al.	6,758,763 B2	7/2004	Murphy et al.
6,435,977 B1	8/2002	Helmstetter et al.	6,766,726 B1	7/2004	Schwarzkopf
6,436,142 B1	8/2002	Paes et al.	6,773,359 B1	8/2004	Lee
6,440,008 B2	8/2002	Murphy et al.	6,773,360 B2	8/2004	Willett et al.
6,440,009 B1	8/2002	Guibaud et al.	6,773,361 B1	8/2004	Lee
6,440,010 B1	8/2002	Deshmukh	6,776,723 B2	8/2004	Bliss et al.
6,443,851 B1	9/2002	Liberatore	6,776,726 B2	8/2004	Sano
6,458,042 B1	10/2002	Chen	6,783,465 B2	8/2004	Matsunaga
6,458,044 B1	10/2002	Vincent et al.	6,800,038 B2	10/2004	Willett et al.
6,461,249 B2	10/2002	Liberatore	6,800,040 B2	10/2004	Galloway et al.
6,464,598 B1	10/2002	Miller	6,805,643 B1	10/2004	Lin
6,471,604 B2	10/2002	Hocknell et al.	6,808,460 B2	10/2004	Namiki
6,475,101 B2	11/2002	Burrows	6,811,496 B2	11/2004	Wahl et al.
6,475,102 B2	11/2002	Helmstetter et al.	6,821,214 B2	11/2004	Rice
6,478,692 B2	11/2002	Kosmatka	6,824,475 B2	11/2004	Burnett et al.
6,482,106 B2	11/2002	Saso	6,835,145 B2	12/2004	Tsurumaki
6,491,592 B2	12/2002	Cackett et al.	D501,036 S	1/2005	Burrows
6,508,978 B1	1/2003	Deshmukh	D501,523 S	2/2005	Dogan et al.
6,514,154 B1	2/2003	Finn	D501,669 S	2/2005	Burrows
6,524,194 B2	2/2003	McCabe	D501,903 S	2/2005	Tanaka
6,524,197 B2	2/2003	Boone	6,855,068 B2	2/2005	Antonious
6,524,198 B2	2/2003	Takeda	6,860,818 B2	3/2005	Mahaffey et al.
6,527,649 B1	3/2003	Neher et al.	6,860,823 B2	3/2005	Lee
6,527,650 B2	3/2003	Reyes et al.	6,860,824 B2	3/2005	Evans
6,530,847 B1	3/2003	Antonious	6,863,624 B1	3/2005	Kessler
6,530,848 B2	3/2003	Gillig	D504,478 S	4/2005	Burrows
6,533,679 B1	3/2003	McCabe et al.	6,875,124 B2	4/2005	Gilbert et al.
6,547,676 B2	4/2003	Cackett et al.	6,875,129 B2	4/2005	Erickson et al.
6,558,273 B2	5/2003	Kobayashi et al.	6,875,130 B2	4/2005	Nishio
6,565,448 B2	5/2003	Cameron	6,881,158 B2	4/2005	Yang et al.
6,565,452 B2	5/2003	Helmstetter et al.	6,881,159 B2	4/2005	Galloway et al.
6,569,029 B1	5/2003	Hamburger	6,887,165 B2*	5/2005	Tsurumaki
6,569,040 B2	5/2003	Bradstock			A63B 53/0466
6,572,489 B2	6/2003	Miyamoto et al.	6,890,267 B2	5/2005	Mahaffey et al.
6,575,845 B2	6/2003	Andrew et al.	D506,236 S	6/2005	Evans et al.
6,582,323 B2	6/2003	Soracco et al.	6,902,497 B2	6/2005	Deshmukh et al.
6,592,466 B2	7/2003	Helmstetter et al.	6,904,663 B2	6/2005	Willett et al.
6,592,468 B2	7/2003	Vincent et al.	D508,274 S	8/2005	Burrows
6,602,149 B1	8/2003	Jacobson	D508,275 S	8/2005	Burrows
6,605,007 B1	8/2003	Bissonnette et al.	6,923,734 B2	8/2005	Meyer
6,607,452 B2	8/2003	Helmstetter et al.	6,926,619 B2	8/2005	Helmstetter et al.
			6,929,563 B2	8/2005	Nishitani

(56)

References Cited

U.S. PATENT DOCUMENTS

6,932,717 B2	8/2005	Hou et al.	D552,701 S	10/2007	Ruggiero et al.	
6,960,141 B2	11/2005	Noguchi et al.	7,278,927 B2	10/2007	Gibbs et al.	
6,960,142 B2	11/2005	Bissonnette et al.	7,281,985 B2	10/2007	Galloway	
6,964,617 B2	11/2005	Williams	D554,720 S	11/2007	Barez et al.	
6,974,393 B2	12/2005	Caldwell et al.	7,291,074 B2	11/2007	Kouno et al.	
6,984,180 B2	1/2006	Hasebe	7,294,064 B2*	11/2007	Tsurumaki	A63B 53/0466
6,988,960 B2	1/2006	Mahaffey et al.				473/329
6,991,558 B2	1/2006	Beach et al.	7,294,065 B2	11/2007	Liang et al.	
6,991,560 B2	1/2006	Tseng	7,297,072 B2	11/2007	Meyer et al.	
D515,165 S	2/2006	Zimmerman et al.	7,303,488 B2	12/2007	Kakiuchi et al.	
6,994,636 B2	2/2006	Hocknell et al.	7,306,527 B2	12/2007	Williams et al.	
6,994,637 B2	2/2006	Murphy et al.	7,314,418 B2	1/2008	Galloway et al.	
6,997,820 B2	2/2006	Willett et al.	7,318,782 B2	1/2008	Imamoto et al.	
7,004,849 B2	2/2006	Cameron	7,320,646 B2	1/2008	Galloway et al.	
7,004,852 B2	2/2006	Billings	D561,286 S	2/2008	Morales et al.	
D518,129 S	3/2006	Poynor et al.	7,338,387 B2	3/2008	Nycum et al.	
7,022,028 B2	4/2006	Nagai et al.	7,338,388 B2*	3/2008	Schweigert	A63B 53/0466
7,025,692 B2	4/2006	Erickson et al.				473/342
7,029,403 B2	4/2006	Rice et al.	7,344,452 B2	3/2008	Imamoto et al.	
D520,585 S	5/2006	Hasebe	7,347,795 B2	3/2008	Yangishi et al.	
D523,104 S	6/2006	Hasebe	D567,317 S	4/2008	Jertson et al.	
7,070,512 B2	7/2006	Nishio	7,354,355 B2	4/2008	Tavares et al.	
7,070,517 B2	7/2006	Cackett et al.	7,377,860 B2	5/2008	Breier et al.	
7,077,762 B2	7/2006	Kouno et al.	7,387,577 B2	6/2008	Murphy et al.	
7,082,665 B2	8/2006	Deshmukh et al.	7,390,266 B2	6/2008	Gwon	
7,083,531 B2	8/2006	Aguinaldo et al.	7,396,293 B2	7/2008	Soracco	
7,094,159 B2	8/2006	Takeda	7,396,296 B2	7/2008	Evans et al.	
7,097,572 B2	8/2006	Yabu	7,402,112 B2	7/2008	Galloway et al.	
7,101,289 B2*	9/2006	Gibbs	7,407,447 B2	8/2008	Beach et al.	
		A63B 53/04	7,407,448 B2	8/2008	Stevens et al.	
		473/329	7,413,520 B1	8/2008	Hocknell et al.	
7,112,148 B2	9/2006	Deshmukh	D577,090 S	9/2008	Pergande et al.	
7,118,493 B2	10/2006	Galloway	7,419,441 B2	9/2008	Hoffman et al.	
7,121,957 B2	10/2006	Hocknell et al.	D579,507 S	10/2008	Llewellyn et al.	
7,125,344 B2	10/2006	Hocknell et al.	7,431,667 B2	10/2008	Vincent et al.	
7,128,661 B2	10/2006	Soracco et al.	7,438,647 B1	10/2008	Hocknell	
D532,474 S	11/2006	Bennett et al.	7,438,649 B2	10/2008	Ezaki et al.	
7,134,971 B2	11/2006	Franklin et al.	7,448,963 B2	11/2008	Beach et al.	
7,137,905 B2	11/2006	Kohno	7,455,598 B2	11/2008	Williams et al.	
7,137,906 B2	11/2006	Tsunoda et al.	7,470,201 B2	12/2008	Nakahara et al.	
7,137,907 B2	11/2006	Gibbs et al.	D584,784 S	1/2009	Barez et al.	
7,140,974 B2	11/2006	Chao et al.	7,476,161 B2	1/2009	Williams et al.	
7,144,334 B2	12/2006	Ehlers et al.	7,491,134 B2	2/2009	Murphy et al.	
7,147,572 B2	12/2006	Kohno	D588,223 S	3/2009	Kuan	
7,147,573 B2	12/2006	Dimarco	7,497,787 B2	3/2009	Murphy et al.	
7,153,220 B2	12/2006	Lo	7,500,924 B2	3/2009	Yokota	
7,156,750 B2	1/2007	Nishitani et al.	7,520,820 B2	4/2009	Dimarco	
7,163,468 B2	1/2007	Gibbs et al.	D592,723 S	5/2009	Chau et al.	
7,163,470 B2	1/2007	Galloway et al.	7,530,901 B2	5/2009	Imamoto et al.	
7,166,038 B2	1/2007	Williams et al.	7,530,904 B2	5/2009	Beach et al.	
7,166,040 B2	1/2007	Hoffman et al.	7,540,811 B2	6/2009	Beach et al.	
7,166,041 B2	1/2007	Evans	7,549,933 B2	6/2009	Kumamoto	
7,169,058 B1	1/2007	Fagan	7,549,935 B2	6/2009	Foster et al.	
7,169,060 B2	1/2007	Stevens et al.	7,563,175 B2	7/2009	Nishitani et al.	
D536,402 S	2/2007	Kawami	7,568,985 B2	8/2009	Beach et al.	
7,179,034 B2	2/2007	Ladouceur	7,572,193 B2	8/2009	Yokota	
D538,866 S	3/2007	Kim et al.	7,578,751 B2	8/2009	Williams et al.	
7,186,190 B1	3/2007	Beach et al.	7,578,753 B2	8/2009	Beach et al.	
7,189,169 B2	3/2007	Billings	D600,767 S	9/2009	Horacek et al.	
7,198,575 B2	4/2007	Beach et al.	7,582,024 B2*	9/2009	Shear	A63B 53/04
7,201,669 B2	4/2007	Stites et al.				473/329
D543,600 S	5/2007	Oldknow	7,591,737 B2	9/2009	Gibbs et al.	
7,211,005 B2	5/2007	Lindsay	7,591,738 B2	9/2009	Beach et al.	
7,211,006 B2*	5/2007	Chang	D604,784 S	11/2009	Horacek et al.	
		A63B 53/047	7,621,823 B2	11/2009	Beach et al.	
		473/329	7,628,707 B2	12/2009	Beach et al.	
7,214,143 B2	5/2007	Deshmukh	7,632,194 B2	12/2009	Beach et al.	
7,223,180 B2	5/2007	Willett et al.	7,632,196 B2*	12/2009	Reed	A63B 53/0466
D544,939 S	6/2007	Radcliffe et al.				473/345
7,226,366 B2	6/2007	Galloway	D608,850 S	1/2010	Oldknow	
7,250,007 B2	7/2007	Lu	D609,294 S	2/2010	Oldknow	
7,252,600 B2	8/2007	Murphy et al.	D609,295 S	2/2010	Oldknow	
7,255,654 B2	8/2007	Murphy et al.	D609,296 S	2/2010	Oldknow	
7,258,626 B2	8/2007	Gibbs et al.	D609,763 S	2/2010	Oldknow	
7,258,631 B2	8/2007	Galloway et al.	D609,764 S	2/2010	Oldknow	
7,267,620 B2	9/2007	Chao et al.	D611,555 S	3/2010	Oldknow	
7,273,423 B2	9/2007	Imamoto	D612,004 S	3/2010	Oldknow	
			D612,005 S	3/2010	Oldknow	
			D612,440 S	3/2010	Oldknow	

(56)

References Cited

U.S. PATENT DOCUMENTS

7,674,187 B2	3/2010	Cackett et al.	9,101,808 B2	8/2015	Stites et al.
7,674,189 B2	3/2010	Beach et al.	9,168,428 B2	10/2015	Albertsen et al.
7,682,264 B2	3/2010	Hsu et al.	9,168,434 B2	10/2015	Burnett et al.
7,717,807 B2	5/2010	Evans et al.	9,174,101 B2	11/2015	Burnett et al.
D616,952 S	6/2010	Oldknow	9,265,993 B2	2/2016	Albertsen et al.
7,731,603 B2	6/2010	Beach et al.	9,403,069 B2	8/2016	Boyd et al.
7,744,484 B1	6/2010	Chao	9,566,479 B2	2/2017	Albertsen et al.
7,749,096 B2	7/2010	Gibbs et al.	9,610,482 B2	4/2017	Burnett et al.
7,749,097 B2	7/2010	Foster et al.	9,610,483 B2*	4/2017	Burnett et al. A63B 53/04
7,753,806 B2	7/2010	Beach et al.	9,694,255 B2	7/2017	Oldknow et al.
7,771,291 B1	8/2010	Willett et al.	9,950,222 B2	4/2018	Albertsen
7,789,773 B2	9/2010	Rae et al.	9,950,223 B2	4/2018	Burnett et al.
7,815,520 B2	10/2010	Frame et al.	9,956,460 B2	5/2018	Burnett et al.
7,857,711 B2*	12/2010	Shear A63B 60/52	10,065,090 B2	9/2018	Guerrette et al.
		473/329	10,245,485 B2	4/2019	Burnett et al.
7,857,713 B2	12/2010	Yokota	10,300,350 B2	5/2019	Albertsen
D631,119 S	1/2011	Albertsen et al.	10,369,429 B2	8/2019	Burnett et al.
7,867,105 B2	1/2011	Moon	10,406,414 B2	9/2019	Galvan et al.
7,887,434 B2	2/2011	Beach et al.	10,556,160 B2	2/2020	Burnett et al.
7,922,604 B2	4/2011	Roach et al.	2001/0049310 A1	12/2001	Cheng et al.
7,927,229 B2	4/2011	Jertson et al.	2002/0022535 A1	2/2002	Takeda
7,946,931 B2	5/2011	Oyama	2002/0025861 A1	2/2002	Ezawa
7,988,565 B2	8/2011	Abe	2002/0032075 A1	3/2002	Vatsvog
8,012,038 B1*	9/2011	Beach A63B 60/02	2002/0055396 A1	5/2002	Nishimoto et al.
		473/329	2002/0072434 A1	6/2002	Yabu
8,012,039 B2	9/2011	Greaney et al.	2002/0077195 A1	6/2002	Carr et al.
8,047,931 B2*	11/2011	Yokota A63B 53/0466	2002/0115501 A1	8/2002	Chen
		473/342	2002/0123394 A1	9/2002	Tsurumaki
8,083,609 B2*	12/2011	Burnett A63B 53/0466	2002/0137576 A1	9/2002	Dammen
		473/327	2002/0160854 A1	10/2002	Beach et al.
8,088,021 B2*	1/2012	Albertsen A63B 53/0466	2002/0183130 A1	12/2002	Pacinella
		473/327	2002/0183134 A1	12/2002	Allen et al.
8,096,897 B2	1/2012	Beach et al.	2003/0013545 A1	1/2003	Vincent et al.
8,118,689 B2	2/2012	Beach et al.	2003/0032500 A1	2/2003	Nakahara et al.
8,157,672 B2	4/2012	Greaney et al.	2003/0036442 A1	2/2003	Chao et al.
8,162,775 B2	4/2012	Tavares et al.	2003/0130059 A1	7/2003	Billings
8,167,737 B2	5/2012	Oyama	2003/0176238 A1	9/2003	Galloway et al.
8,187,119 B2	5/2012	Rae et al.	2003/0220154 A1	11/2003	Anelli
8,206,241 B2	6/2012	Boyd et al.	2004/0087388 A1	5/2004	Beach et al.
8,206,244 B2	6/2012	Honea et al.	2004/0121852 A1	6/2004	Tsurumaki
8,216,087 B2	7/2012	Breier et al.	2004/0157678 A1	8/2004	Kohno
8,235,841 B2	8/2012	Stites et al.	2004/0176180 A1	9/2004	Yamaguchi et al.
8,235,844 B2*	8/2012	Albertsen A63B 53/0466	2004/0176183 A1	9/2004	Tsurumaki
		473/345	2004/0192463 A1	9/2004	Tsurumaki et al.
8,241,143 B2	8/2012	Albertsen et al.	2004/0235584 A1	11/2004	Chao et al.
8,241,144 B2	8/2012	Albertsen et al.	2004/0242343 A1	12/2004	Chao et al.
8,292,756 B2	10/2012	Greaney et al.	2005/0003905 A1	1/2005	Kim et al.
8,328,659 B2	12/2012	Shear	2005/0026716 A1	2/2005	Wahl et al.
8,353,786 B2	1/2013	Beach et al.	2005/0049081 A1	3/2005	Boone
8,403,771 B1	3/2013	Rice et al.	2005/0101404 A1	5/2005	Long et al.
8,430,763 B2	4/2013	Beach et al.	2005/0119070 A1	6/2005	Kumamoto
8,435,134 B2	5/2013	Tang et al.	2005/0137024 A1	6/2005	Stites et al.
8,496,544 B2	7/2013	Curtis et al.	2005/0181884 A1	8/2005	Beach et al.
8,517,860 B2	8/2013	Albertsen	2005/0239575 A1	10/2005	Chao et al.
8,529,368 B2	9/2013	Rice et al.	2006/0009305 A1	1/2006	Lindsay
8,574,094 B2	11/2013	Nicolette et al.	2006/0035722 A1	2/2006	Beach et al.
8,591,351 B2	11/2013	Albertsen et al.	2006/0052177 A1	3/2006	Nakahara et al.
8,616,999 B2	12/2013	Greaney et al.	2006/0058112 A1	3/2006	Haralason et al.
8,641,555 B2	2/2014	Stites et al.	2006/0073910 A1	4/2006	Imamoto et al.
8,663,029 B2	3/2014	Beach et al.	2006/0084525 A1	4/2006	Imamoto et al.
8,696,491 B1	4/2014	Myers	2006/0094535 A1	5/2006	Cameron
8,721,471 B2	5/2014	Albertsen et al.	2006/0116218 A1	6/2006	Burnett et al.
8,727,909 B2	5/2014	Guerrette et al.	2006/0122004 A1	6/2006	Chen et al.
8,753,222 B2	6/2014	Beach et al.	2006/0154747 A1	7/2006	Beach
8,821,312 B2*	9/2014	Burnett A63B 60/52	2006/0172821 A1	8/2006	Evans et al.
		473/329	2006/0240908 A1	10/2006	Adams et al.
8,827,831 B2	9/2014	Burnett et al.	2006/0281581 A1	12/2006	Yamamoto
8,834,289 B2	9/2014	de la Cruz et al.	2007/0026961 A1	2/2007	Hou
8,858,360 B2	10/2014	Rice et al.	2007/0049416 A1	3/2007	Shear
8,900,069 B2	12/2014	Beach et al.	2007/0049417 A1	3/2007	Shear
8,956,240 B2	2/2015	Beach et al.	2007/0082751 A1	4/2007	Lo et al.
8,956,242 B2	2/2015	Rice et al.	2007/0099726 A1	5/2007	Rife
9,011,267 B2	4/2015	Burnett et al.	2007/0105646 A1	5/2007	Beach et al.
9,089,749 B2	7/2015	Burnett et al.	2007/0105647 A1	5/2007	Beach et al.
			2007/0105648 A1	5/2007	Beach et al.
			2007/0105649 A1	5/2007	Beach et al.
			2007/0105650 A1	5/2007	Beach et al.
			2007/0105651 A1	5/2007	Beach et al.

(56)

References Cited

FOREIGN PATENT DOCUMENTS

JP	2003038691	2/2003	
JP	2003052866	2/2003	
JP	2003062135	3/2003	
JP	2003062135	A *	3/2003
JP	2003093554	4/2003	
JP	2003093554	A *	4/2003
JP	2003126311	5/2003 A63B 53/0433
JP	2003154041	5/2003	
JP	2003154041	A *	5/2003
JP	2003210621	7/2003	
JP	2003210627	A	7/2003
JP	2003226952	8/2003	
JP	2003236025	8/2003	
JP	2003236025	A *	8/2003
JP	2003524487	8/2003	
JP	2003-265653	9/2003	
JP	2003265652	9/2003	
JP	2003265652	A *	9/2003
JP	2003265653	A *	9/2003
JP	2004008409	1/2004 A63B 53/0475
JP	2004113370	4/2004 A63B 60/02
JP	2004141451	5/2004	
JP	2004141451	A *	5/2004
JP	2004174224	6/2004 A63B 53/047
JP	2004174224	A *	6/2004
JP	2004183058	7/2004 A63B 53/0466
JP	2004222911	8/2004	
JP	2004232397	8/2004	
JP	2004261451	9/2004	
JP	2004265992	9/2004	
JP	2004267438	9/2004	
JP	2004271516	9/2004	
JP	2004275700	10/2004	
JP	2004313762	11/2004	
JP	2004313762	A *	11/2004
JP	2004-351054	12/2004	
JP	2004351054	12/2004	
JP	2004351173	12/2004	
JP	2004351173	A *	12/2004
JP	2005013711	1/2005	
JP	2005013711	A *	1/2005
JP	2005021649	1/2005 A63B 53/0475
JP	2005021649	A *	1/2005
JP	2005028170	2/2005 A63B 53/047
JP	2005073736	3/2005	
JP	2005111172	4/2005	
JP	2005137494	6/2005	
JP	2005137788	6/2005	
JP	2005137940	6/2005	
JP	2005193069	7/2005	
JP	2005193069	A *	7/2005
JP	2005296458	10/2005	
JP	2005296582	10/2005	
JP	2005319122	11/2005	
JP	2005319122	A *	11/2005
JP	2005323978	11/2005	
JP	2006212066	8/2006	
JP	2006212066	A *	8/2006
JP	3819409	9/2006	
JP	2006320493	11/2006	
JP	2007136069	6/2007	
JP	2007136069	A *	6/2007
JP	3996539	10/2007 A63B 60/52
JP	2007275253	A	10/2007
JP	4046511	2/2008	
JP	4047682	2/2008	
JP	4128970	7/2008	
JP	2008279249	11/2008	
JP	2008279249	A *	11/2008
JP	2009000281	A	1/2009
JP	2009000292	1/2009 A63B 53/0475
JP	06269521	9/2009	
JP	2010029590	A	2/2010
JP	2010279847	A	12/2010
JP	2011024999	A	2/2011

JP	2012526634	11/2012
JP	2013517893	5/2013
JP	2013517894	5/2013
JP	2013517895	5/2013
JP	2013255779	12/2013
JP	2013544178	12/2013
JP	2013544179	12/2013
JP	5404921	2/2014
JP	2014140591	8/2014
JP	2014528291	10/2014
JP	5625048	B
JP	5653457	1/2015
JP	2015517886	6/2015
JP	5827243	12/2015
JP	2017012769	1/2017
JP	6072696	2/2017
JP	6096892	3/2017
JP	2017080609	5/2017
KR	100768417	8/2005
KR	20050084089	8/2005
KR	20070111156	11/2007
WO	WO8802642	4/1988
WO	WO0166199	9/2001
WO	WO02062501	8/2002
WO	WO03061773	7/2003
WO	WO2004043549	5/2004
WO	WO2005/009543	A2
WO	WO2006044631	4/2006
WO	WO2011017011	2/2011
WO	WO2012075177	6/2012
WO	WO2012075178	6/2012
WO	WO2012103340	8/2012

OTHER PUBLICATIONS

Mike Stachura, "The Hot List", Golf Digest Magazine, Feb. 2005, pp. 120-130.

Mike Stachura, "The Hot List", Golf Digest Magazine, Feb. 2005, pp. 131-143.

Mike Stachura, "The Hot List", Golf Digest Magazine, Feb. 2006, pp. 122-132.

Mike Stachura, "The Hot List", Golf Digest Magazine, Feb. 2006, pp. 133-143.

Mike Stachura, "The Hot List", Golf Digest Magazine, Feb. 2007, pp. 130-151.

"The Hot List", Golf Digest Magazine, Feb. 2008, pp. 114-139.

Mike Stachura, Stina Sternberg, "Editor's Choices and Gold Medal Drivers", Golf Digest Magazine, Feb. 2010, pp. 95-109.

The Hot List, Golf Digest Magazine, Feb. 2009, pp. 101-127.

International Searching Authority (USPTO), International Search Report and Written Opinion for International Application No. PCT/US2011/038150, dated Sep. 16, 2011, 13 pages.

"Cleveland HiBore Driver Review," <http://thesandtrip.com>, 7 pages, May 19, 2006.

"Invalidity Search Report for Japanese Registered Patent No. 4128970," 4 pp (dated Nov. 29, 2013).

Office action from the U.S. Patent and Trademark Office in U.S. Appl. No. 13/401,690, dated Feb. 6, 2013.

Office action from the U.S. Patent and Trademark Office in U.S. Appl. No. 13/469,023, dated Jul. 31, 2012.

Office action from the U.S. Patent and Trademark Office in U.S. Appl. No. 13/338,197, dated Jun. 5, 2014.

Office action from the U.S. Patent and Trademark Office in U.S. Appl. No. 13/828,675, dated Jun. 30, 2014.

Restriction Requirement from the U.S. Patent and Trademark Office in U.S. Appl. No. 13/469,031, dated Jun. 5, 2014.

Office action from the U.S. Patent and Trademark office in the U.S. Appl. No. 13/401,690, dated May 23, 2012.

Adams Golf Speedline F11 Ti 14.5 degree fairway wood (www.bombsquadgolf.com, posted Oct. 18, 2010).

Callaway Golf, World's Straightest Driver: FT-i Driver downloaded from www.callawaygolf.com/ft%2Di/driver.aspx?lang=en on Apr. 5, 2007.

Jackson, Jeff, The Modern Guide to Golf Clubmaking, Ohio: Dynacraft Golf Products, Inc., copyright 1994, p. 237.

(56)

References Cited

OTHER PUBLICATIONS

Nike Golf, Sasquatch 460, downloaded from www.nike.com/nikegolf/index.htm on Apr. 5, 2007.

Nike Golf, Sasquatch Sumo Squared Driver, downloaded from www.nike.com/nikegolf/index.htm on Apr. 5, 2007.

Office action from the U.S. Patent and Trademark office in the U.S. Appl. No. 12/781,727, dated Aug. 5, 2010.

Taylor Made Golf Company, Inc. Press Release, Burner Fairway Wood, www.tmag.com/media/pressreleases/2007/011807_burner_fairway_rescue.html, Jan. 26, 2007.

Taylor Made Golf Company Inc., R7 460 Drivers, downloaded from www.taylormadegolf.com/product_detail.asp?PID=14section=overview on Apr. 5, 2007.

Titleist 907D1, downloaded from www.tees2greens.com/forum/Uploads/Images/7ade3521-192b-4611-870b-395d.jpg on Feb. 1, 2007.

* cited by examiner

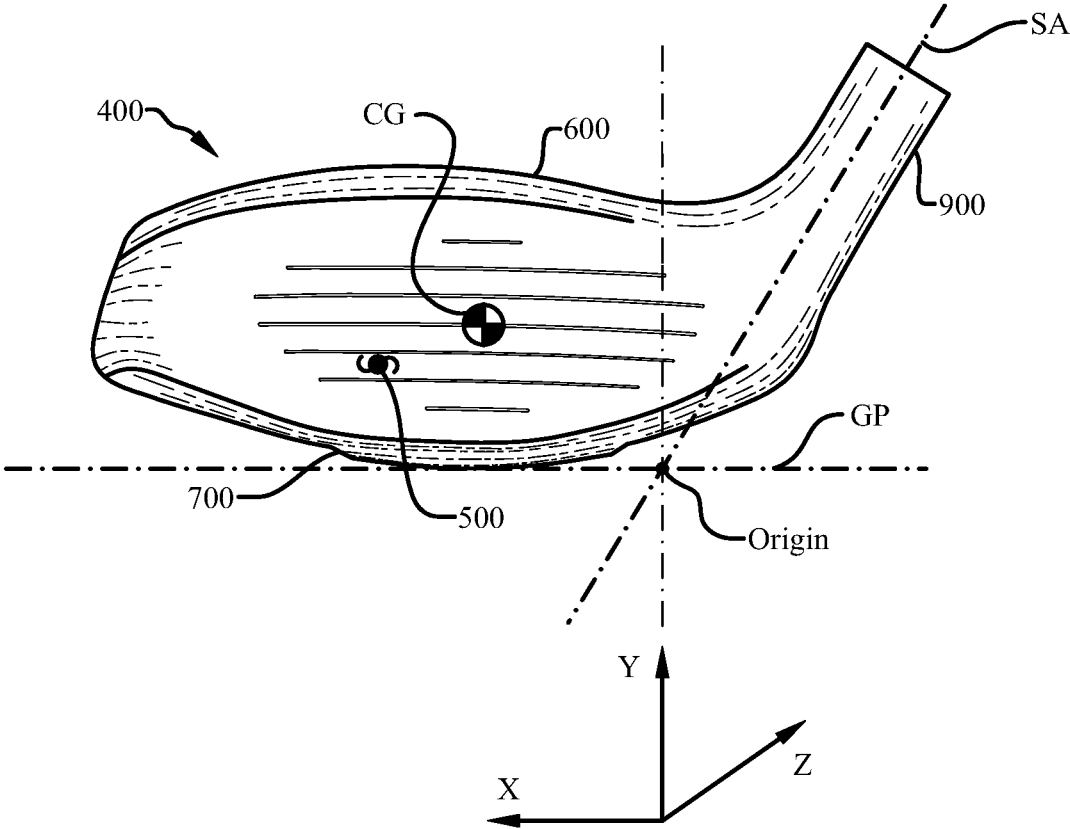

Fig. 1

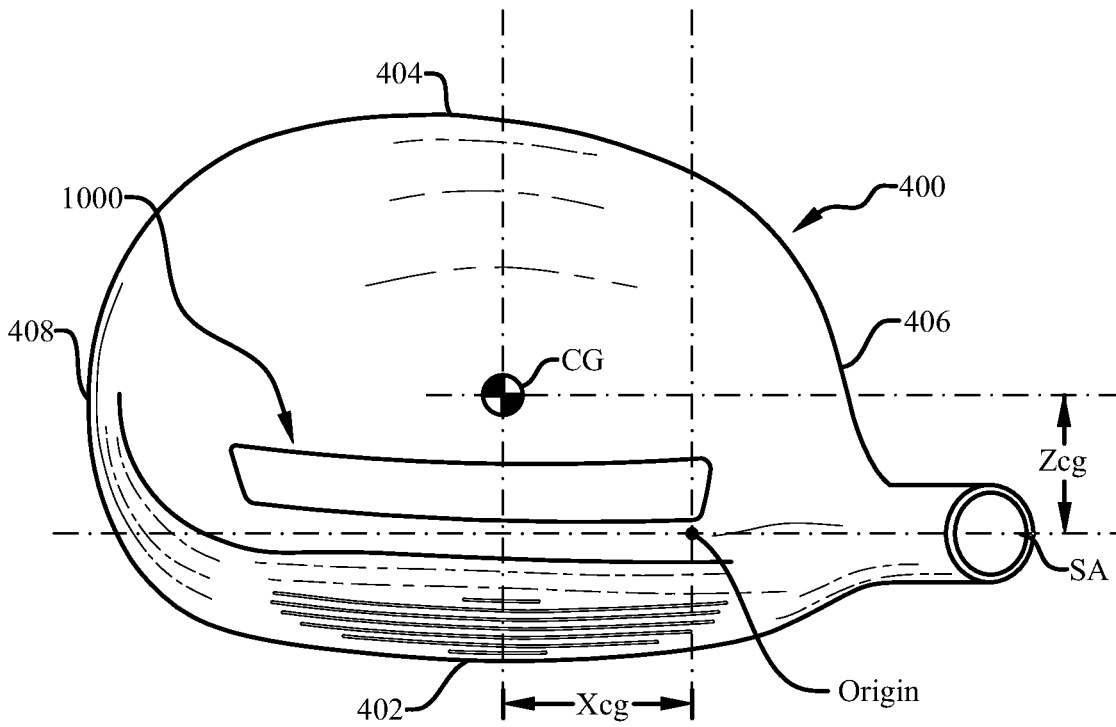

Fig. 2

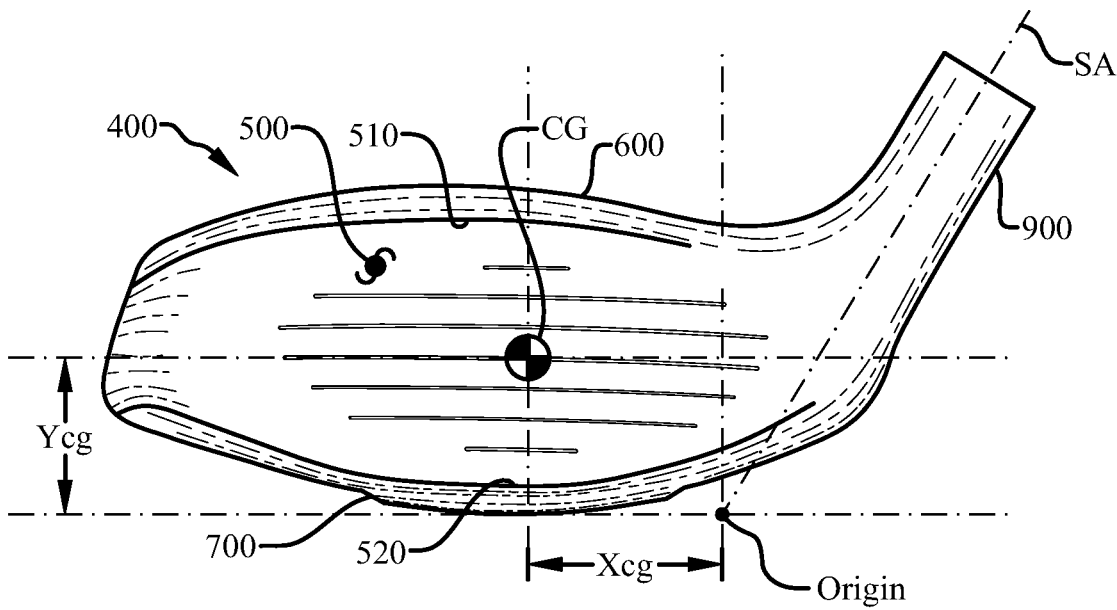

Fig. 3

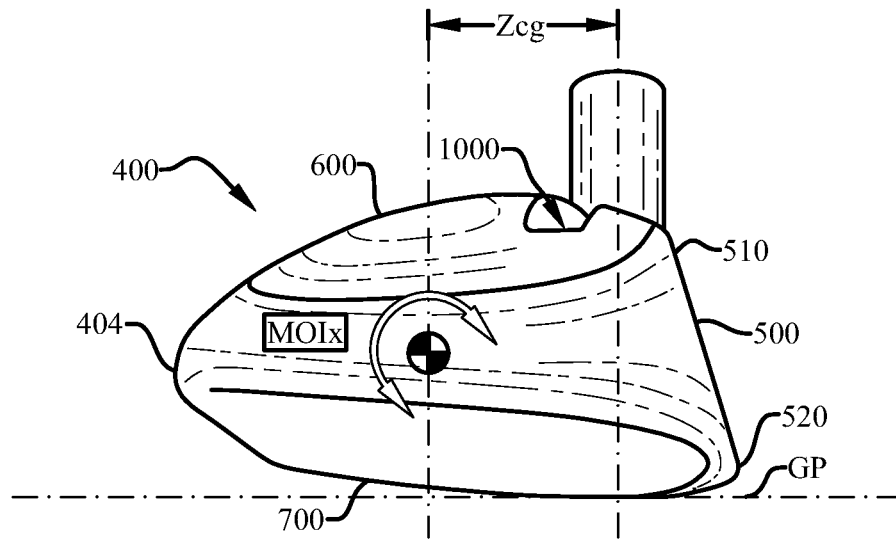

Fig. 4

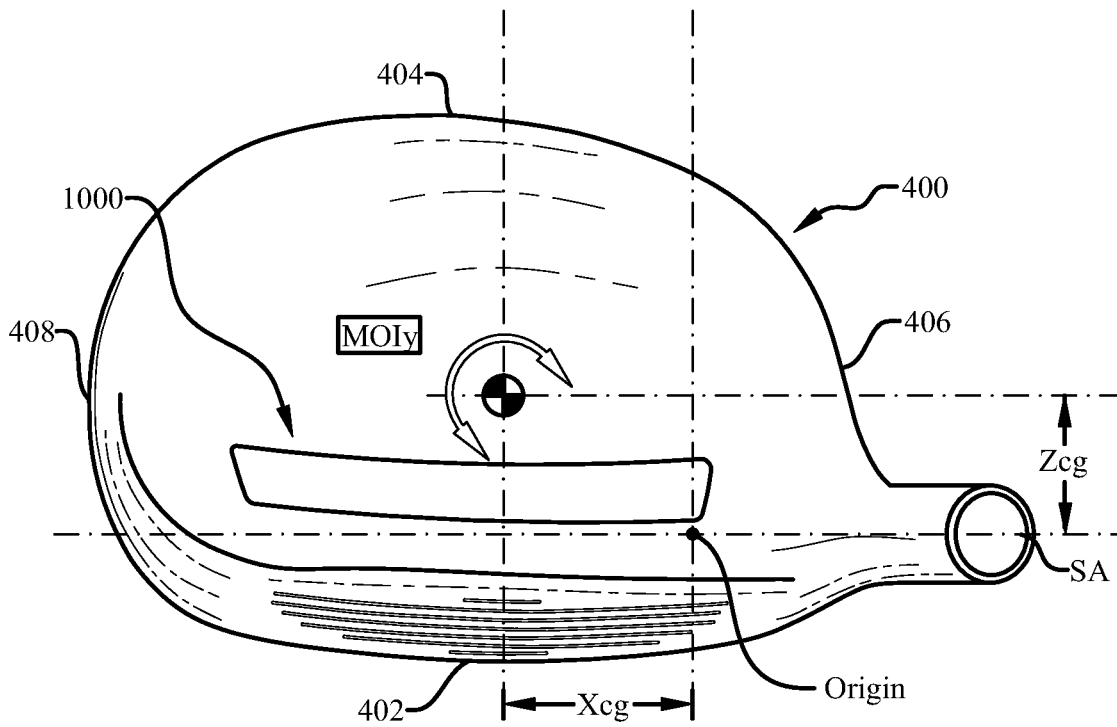

Fig. 5

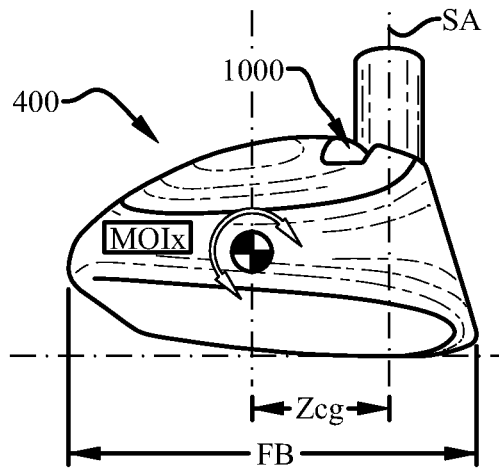

Fig. 6

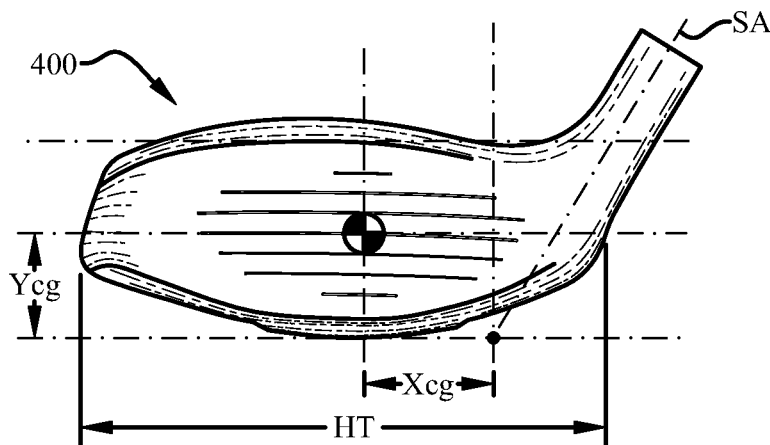

Fig. 7

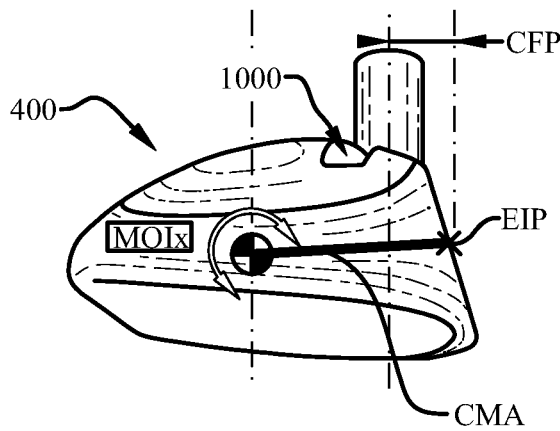

Fig. 8

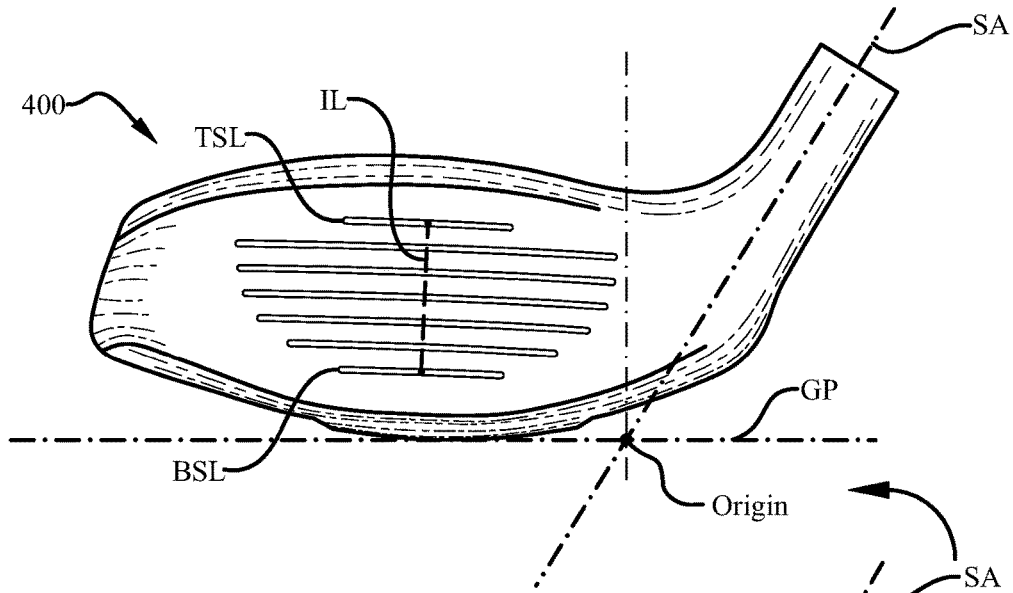

Fig. 9

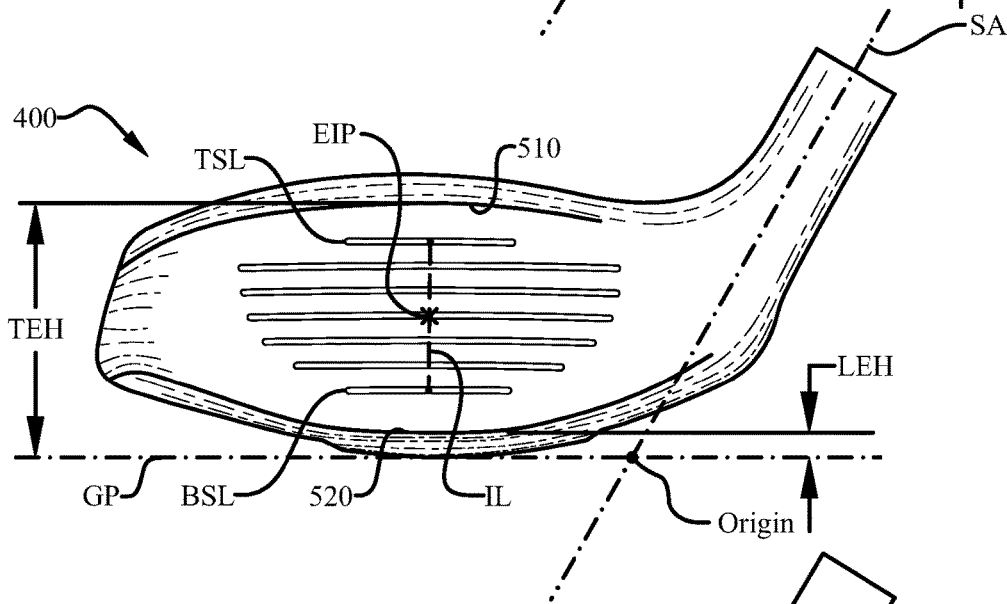

Fig. 10

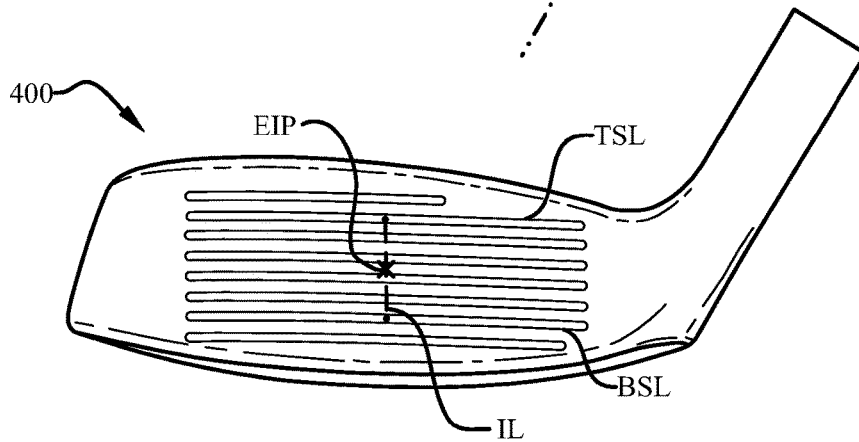

Fig. 11

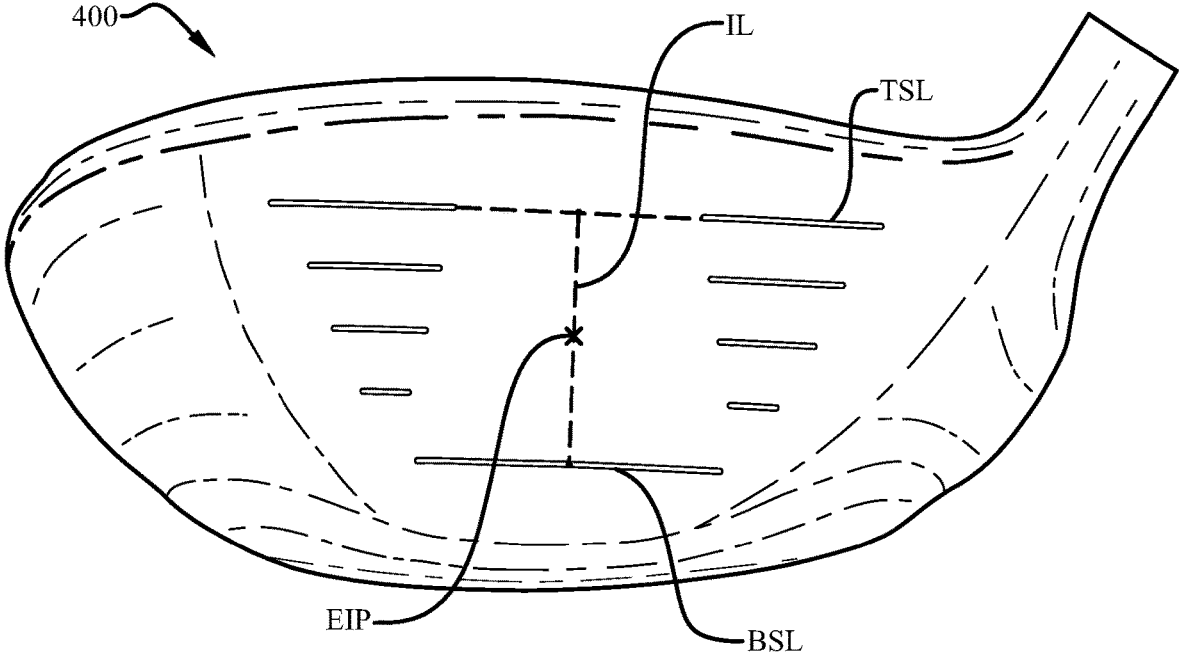
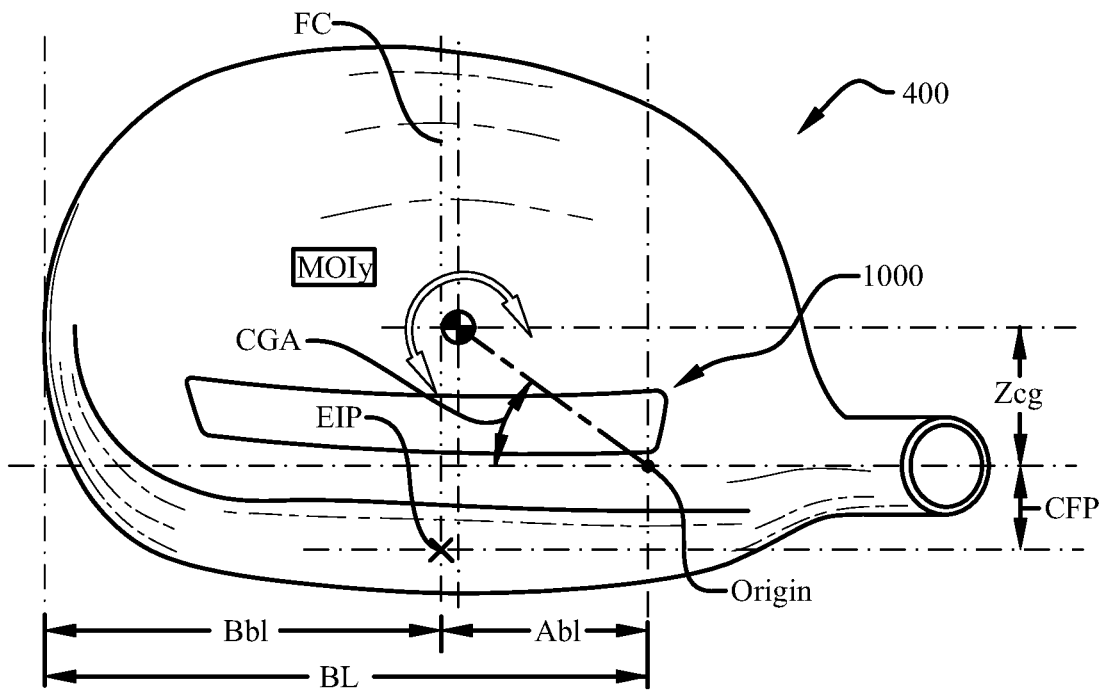
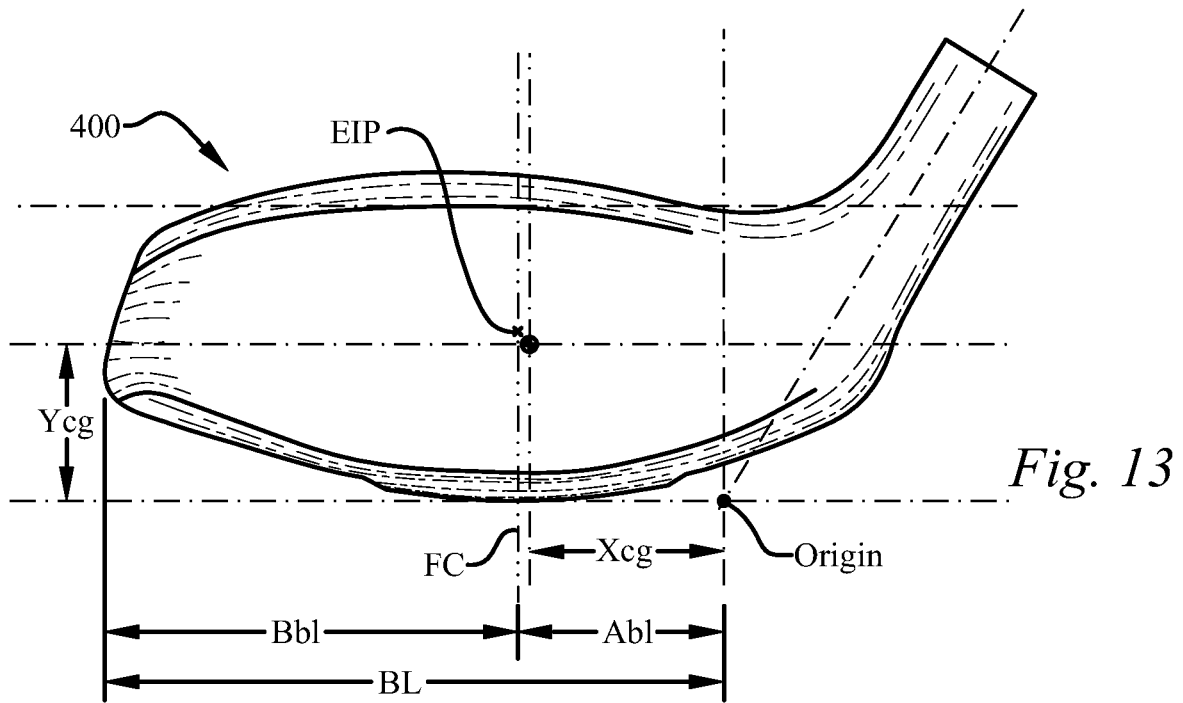

Fig. 12



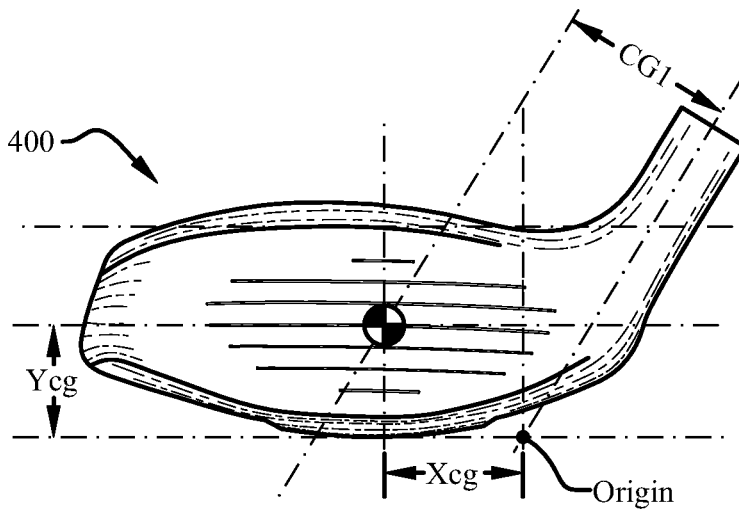

Fig. 15

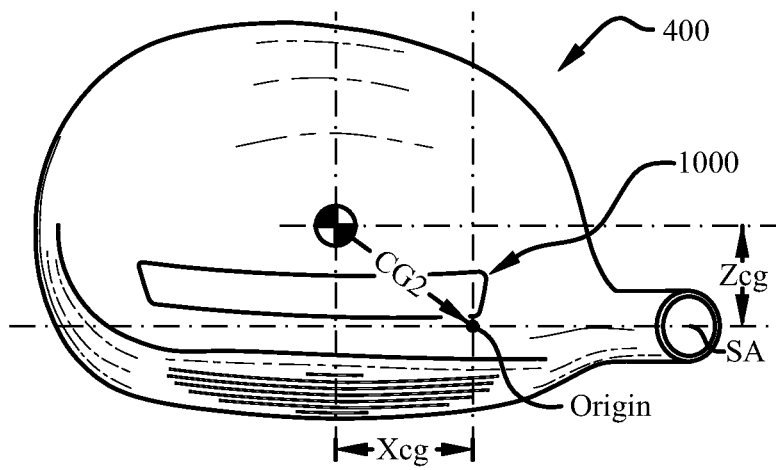

Fig. 16

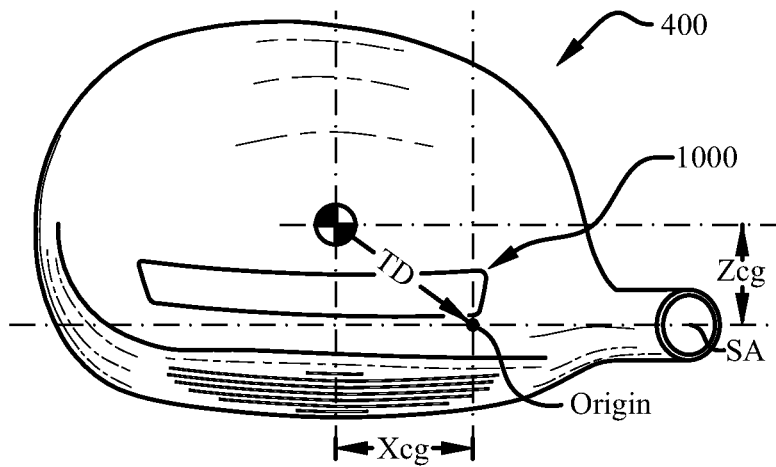

Fig. 17

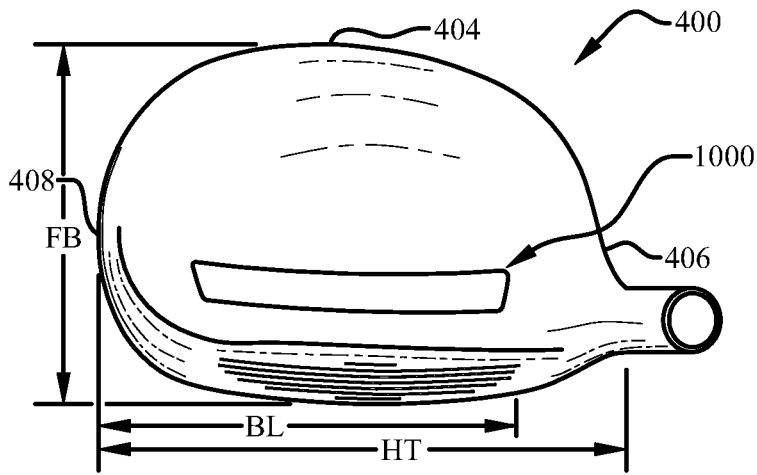

Fig. 18

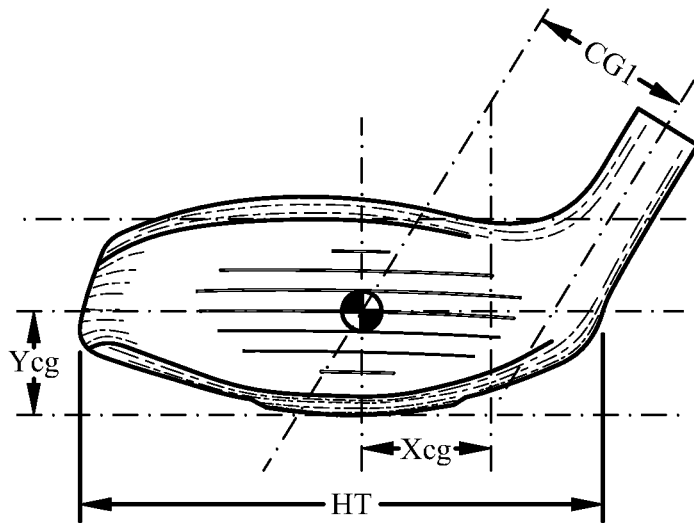

Fig. 19

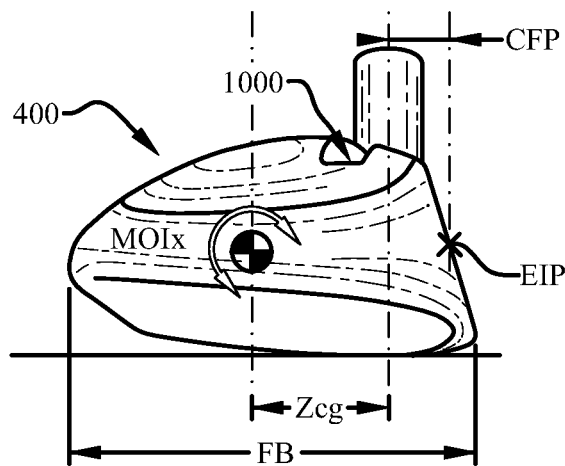

Fig. 20

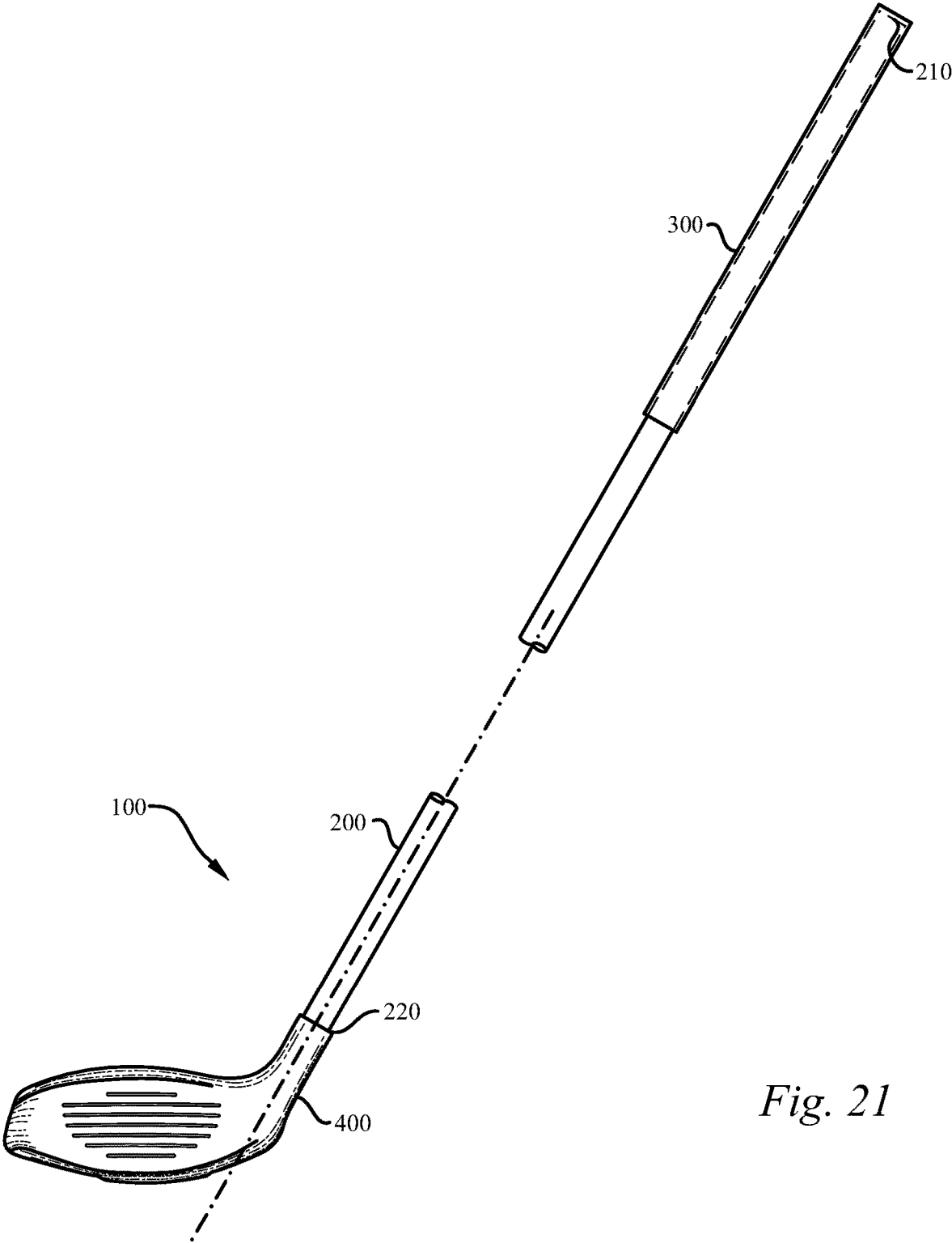
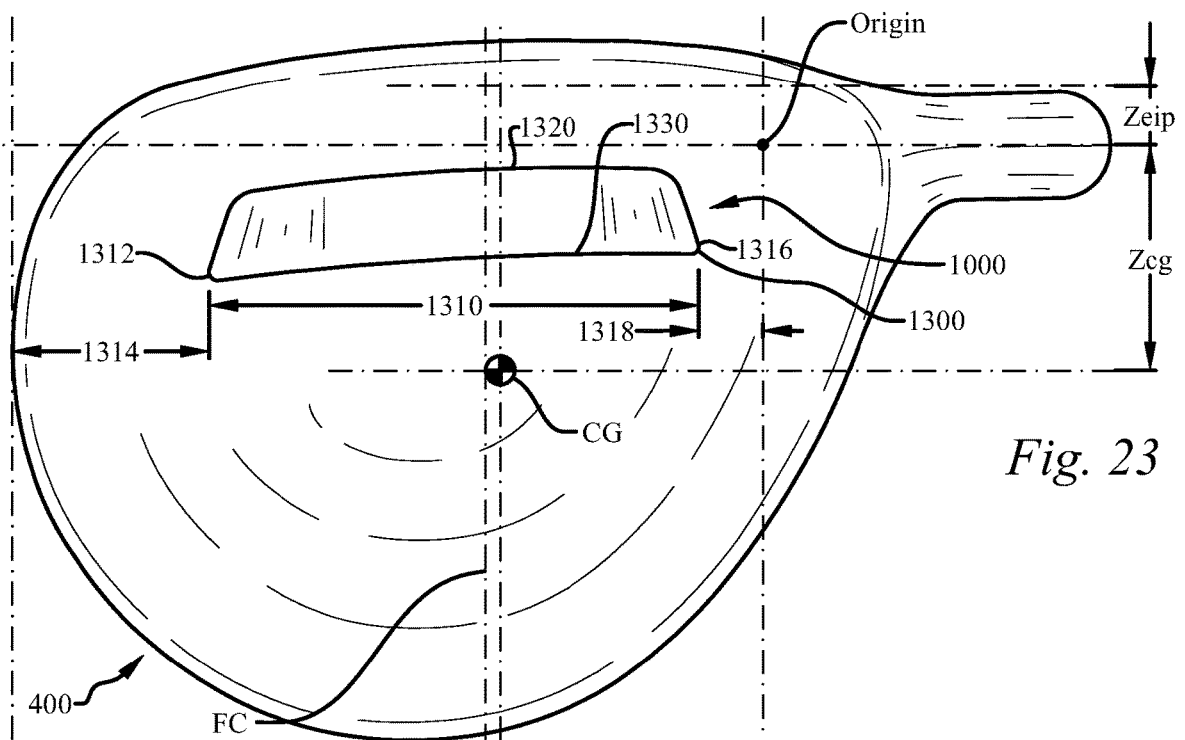
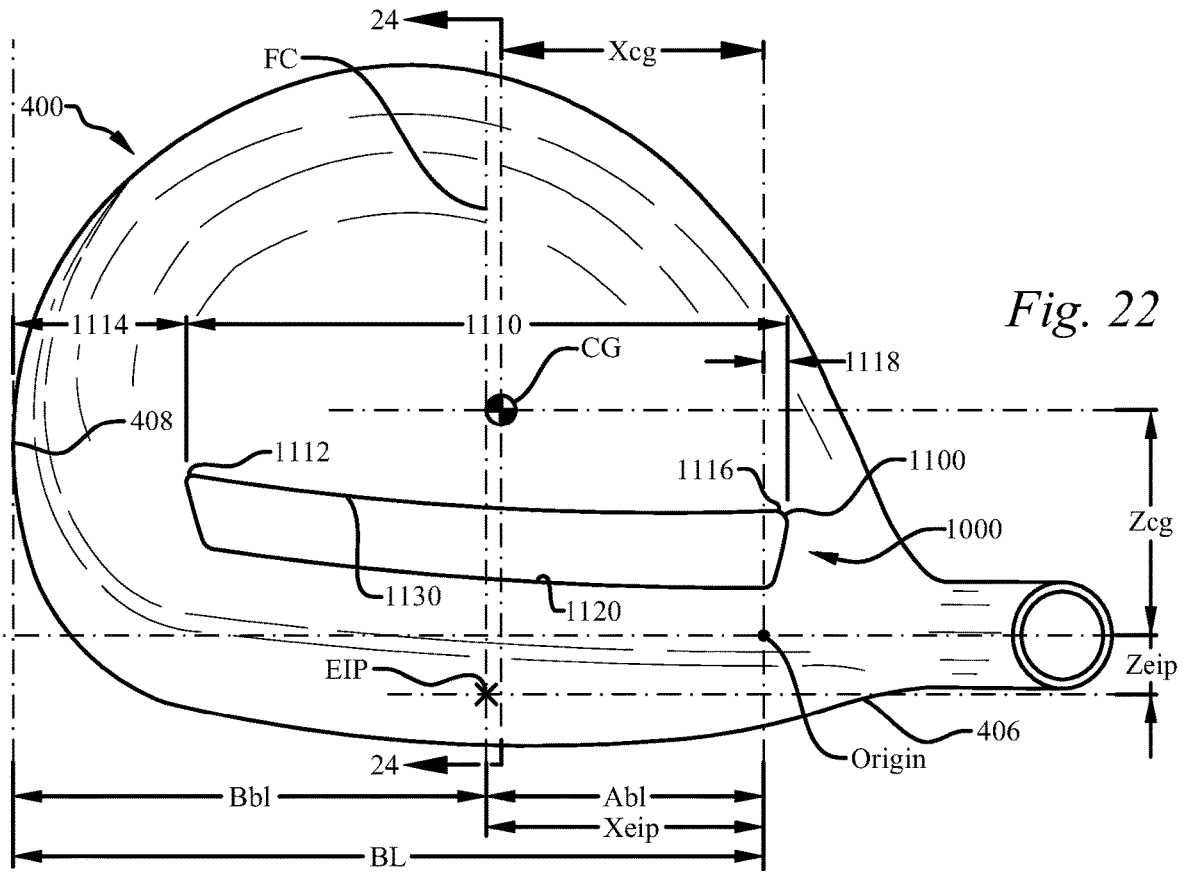

Fig. 21



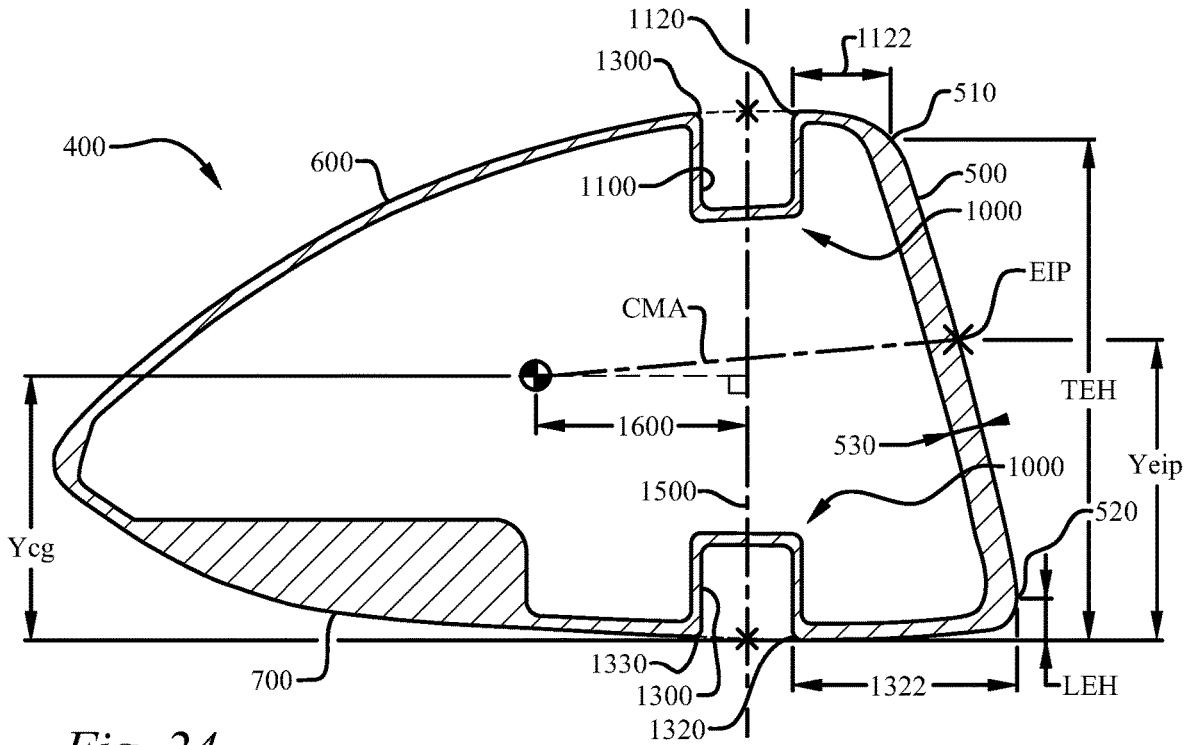

Fig. 24

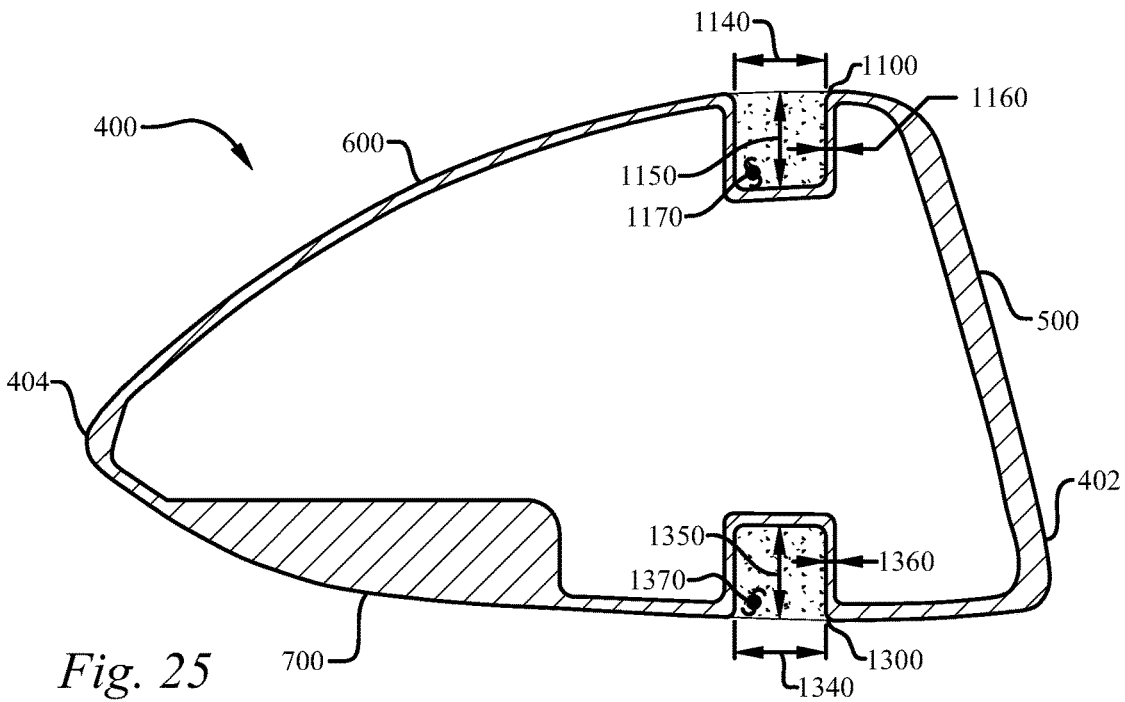

Fig. 25

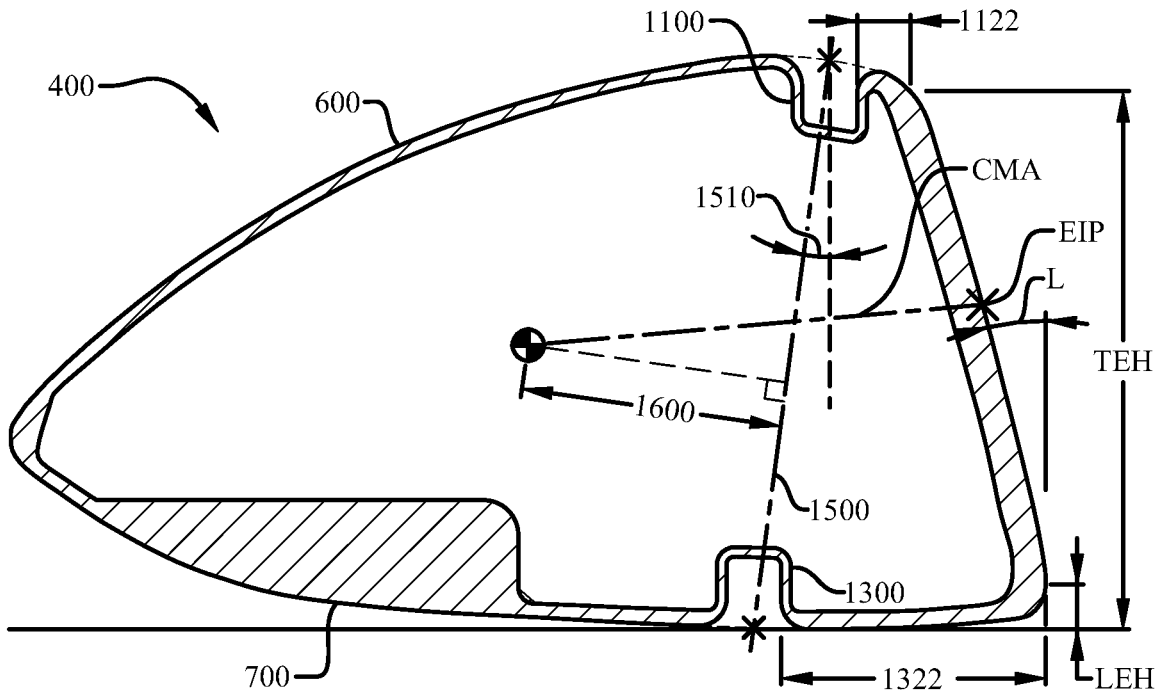

Fig. 26

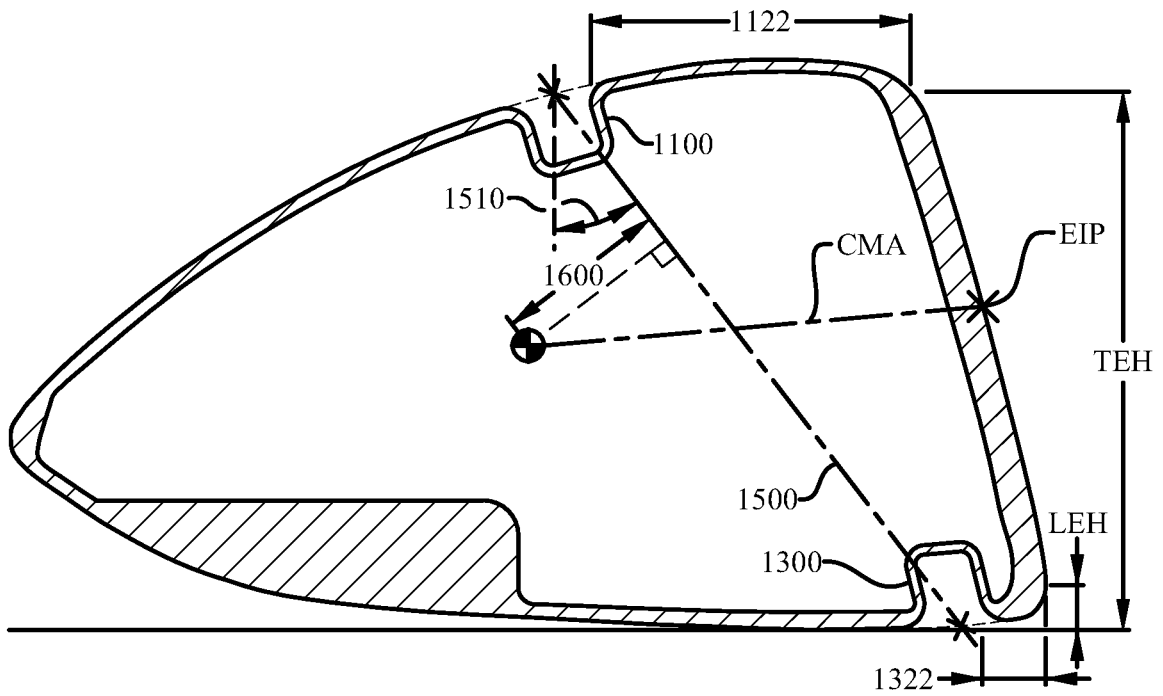

Fig. 27

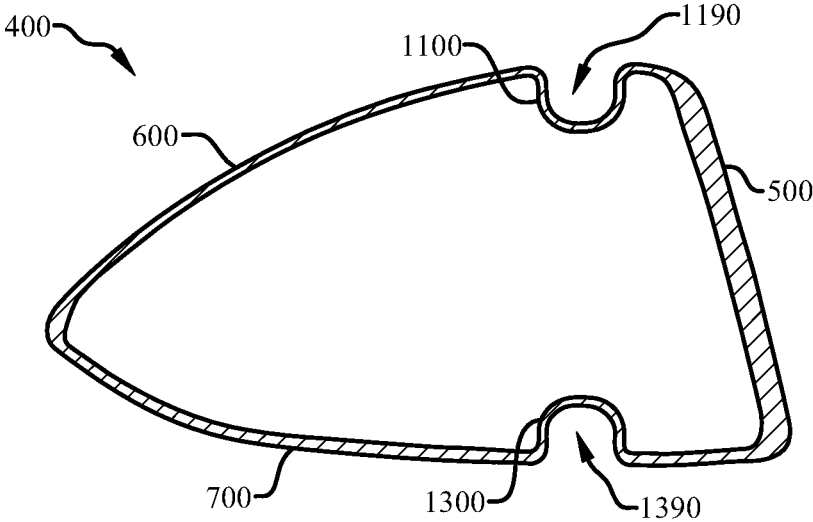

Fig. 28

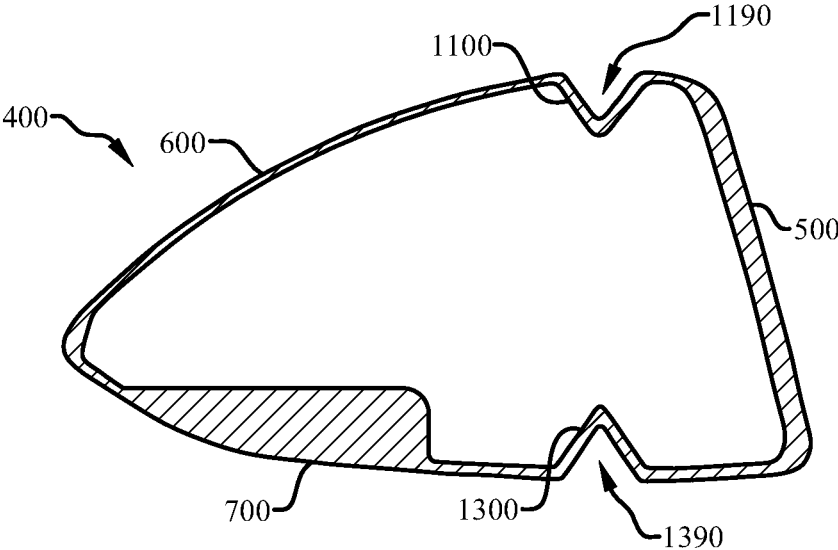

Fig. 29

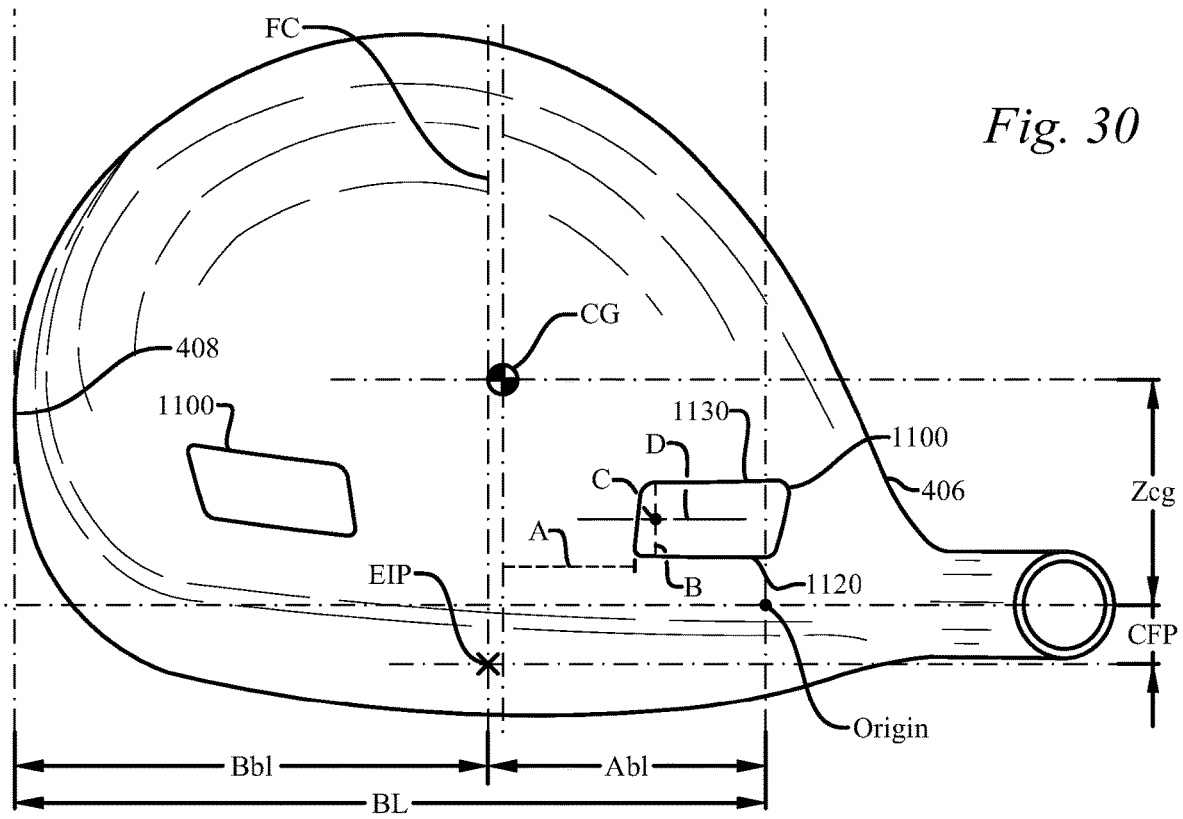

Fig. 30

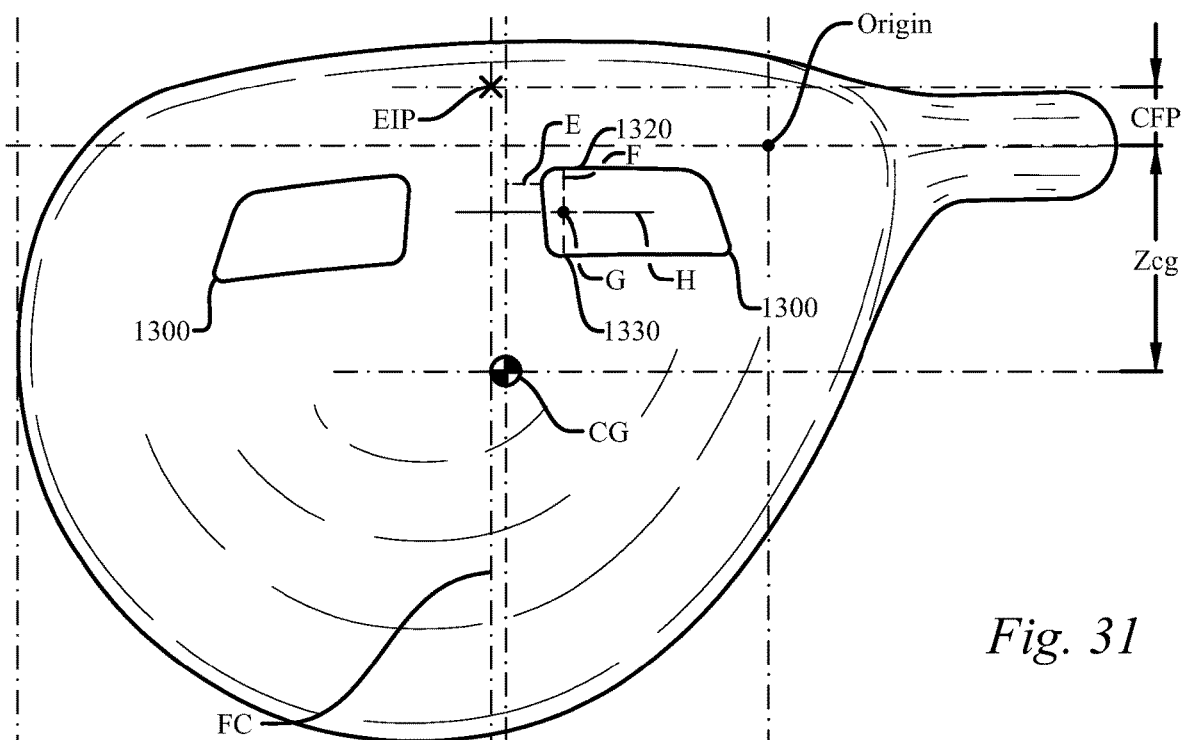
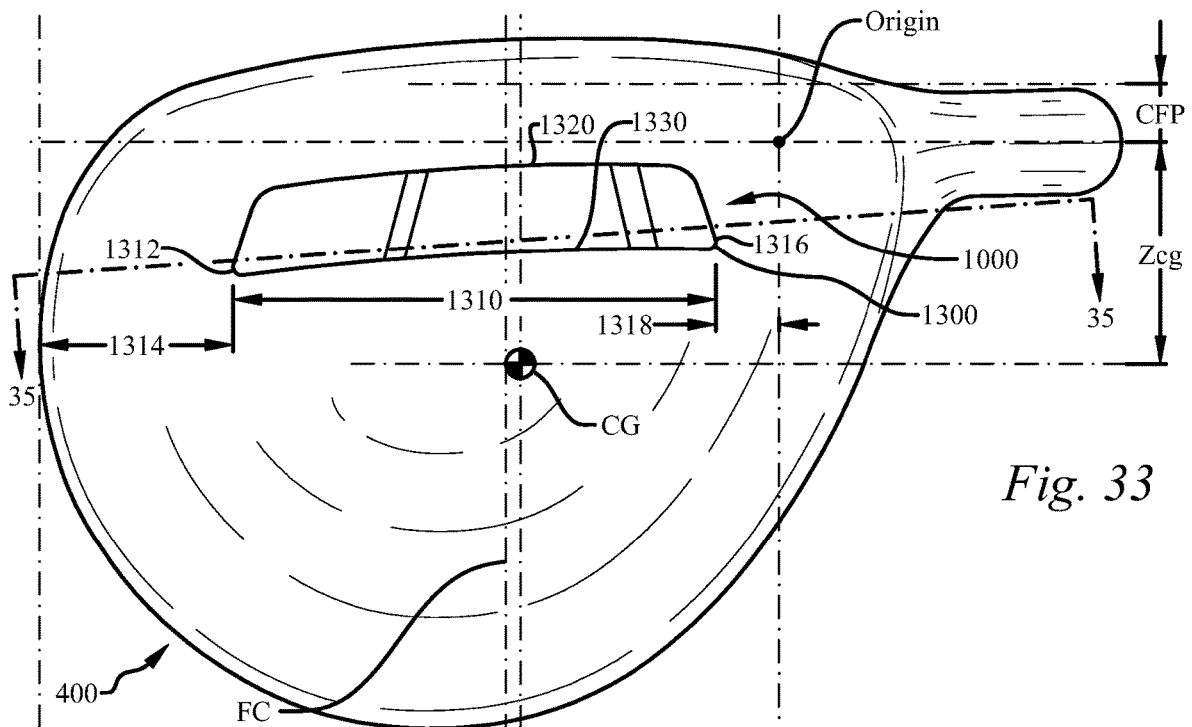
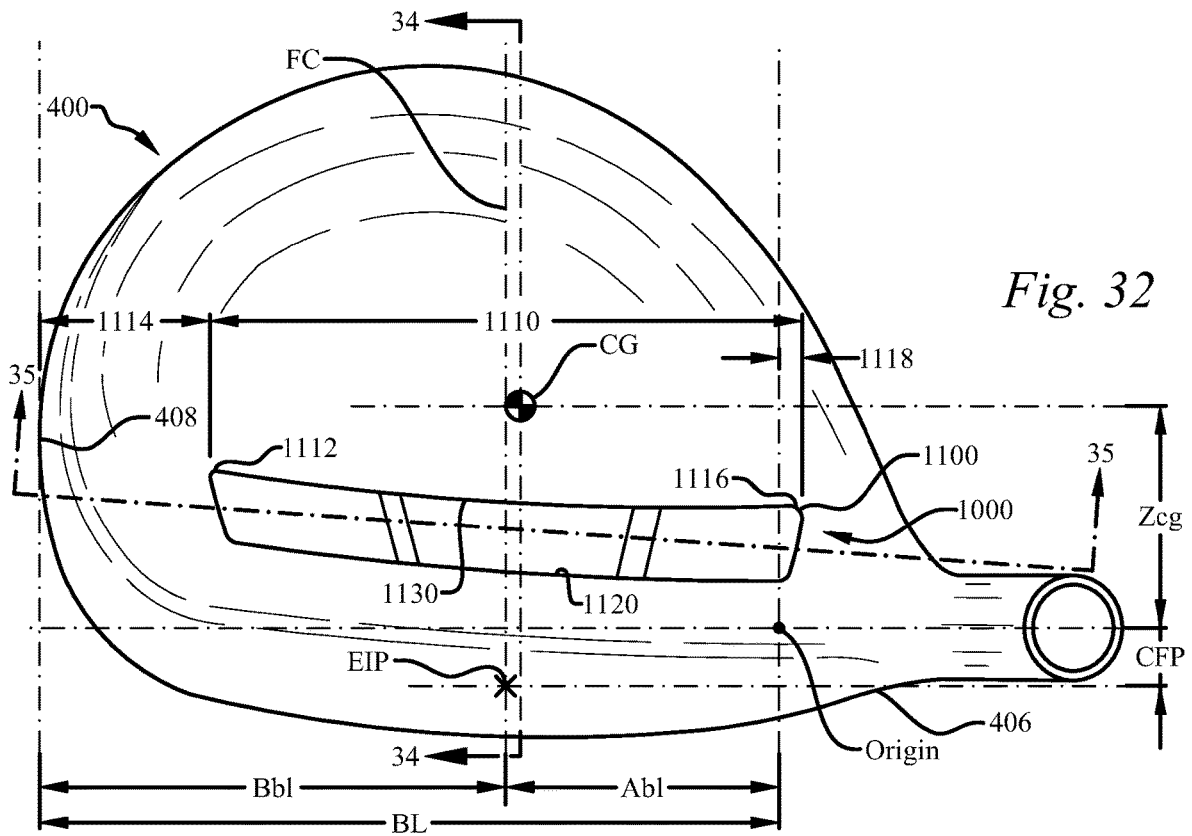

Fig. 31



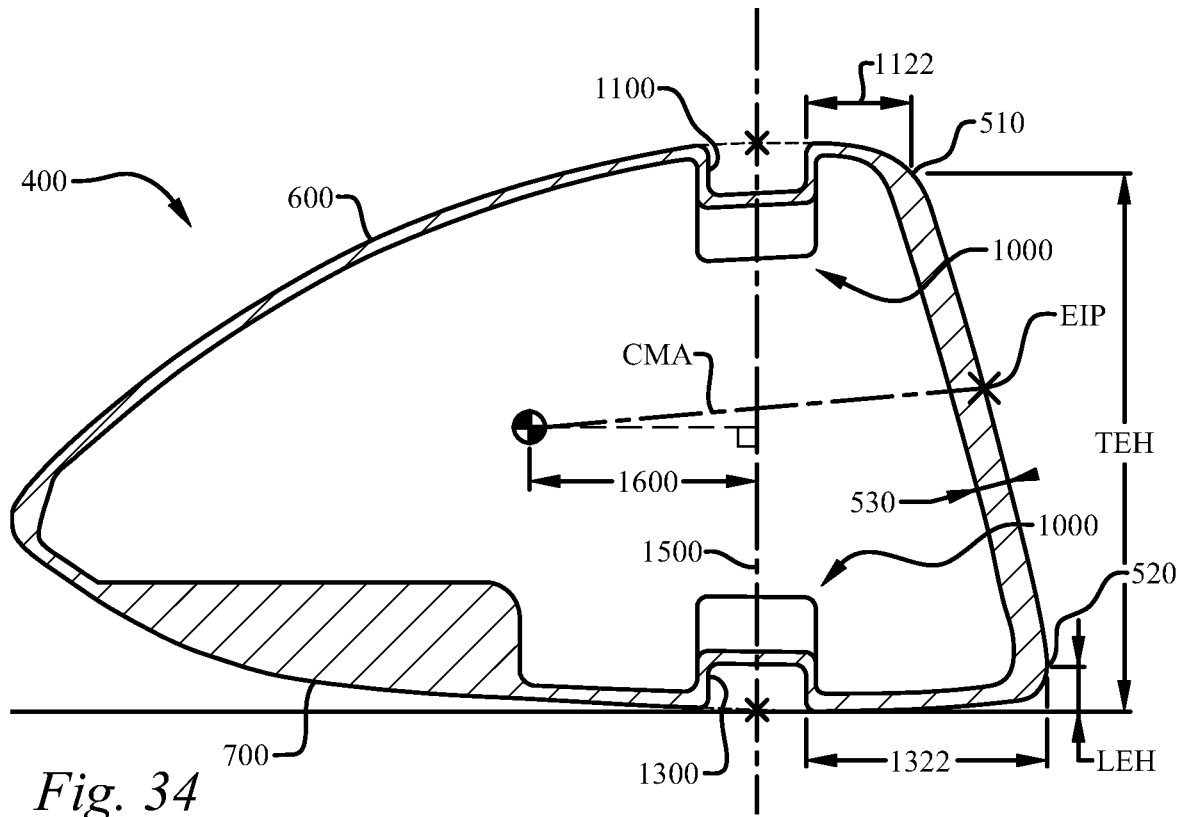

Fig. 34

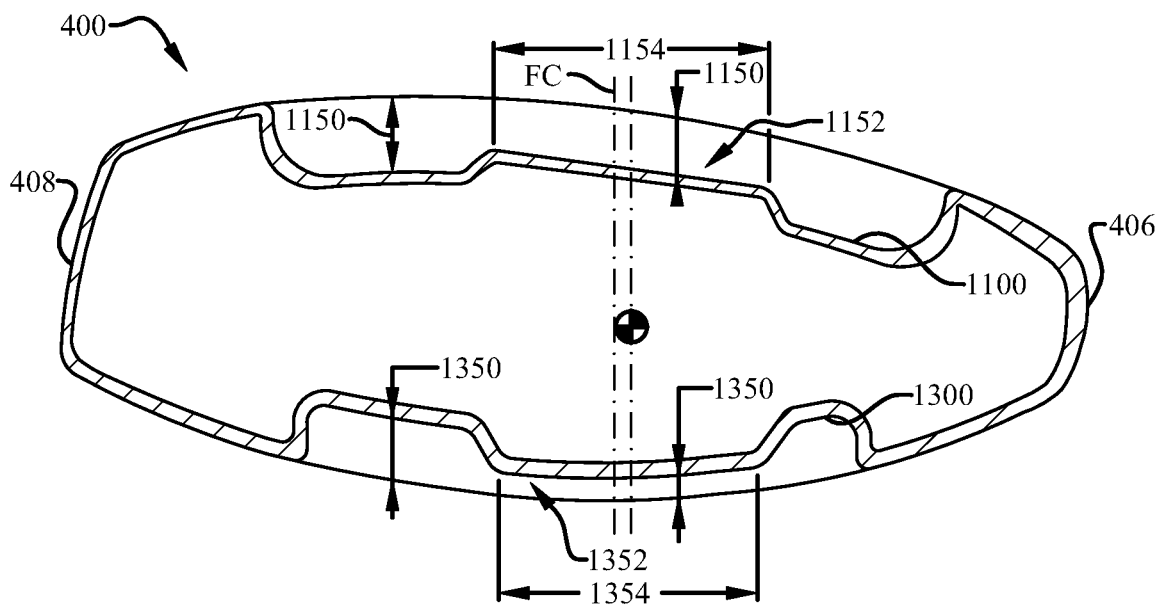

Fig. 35

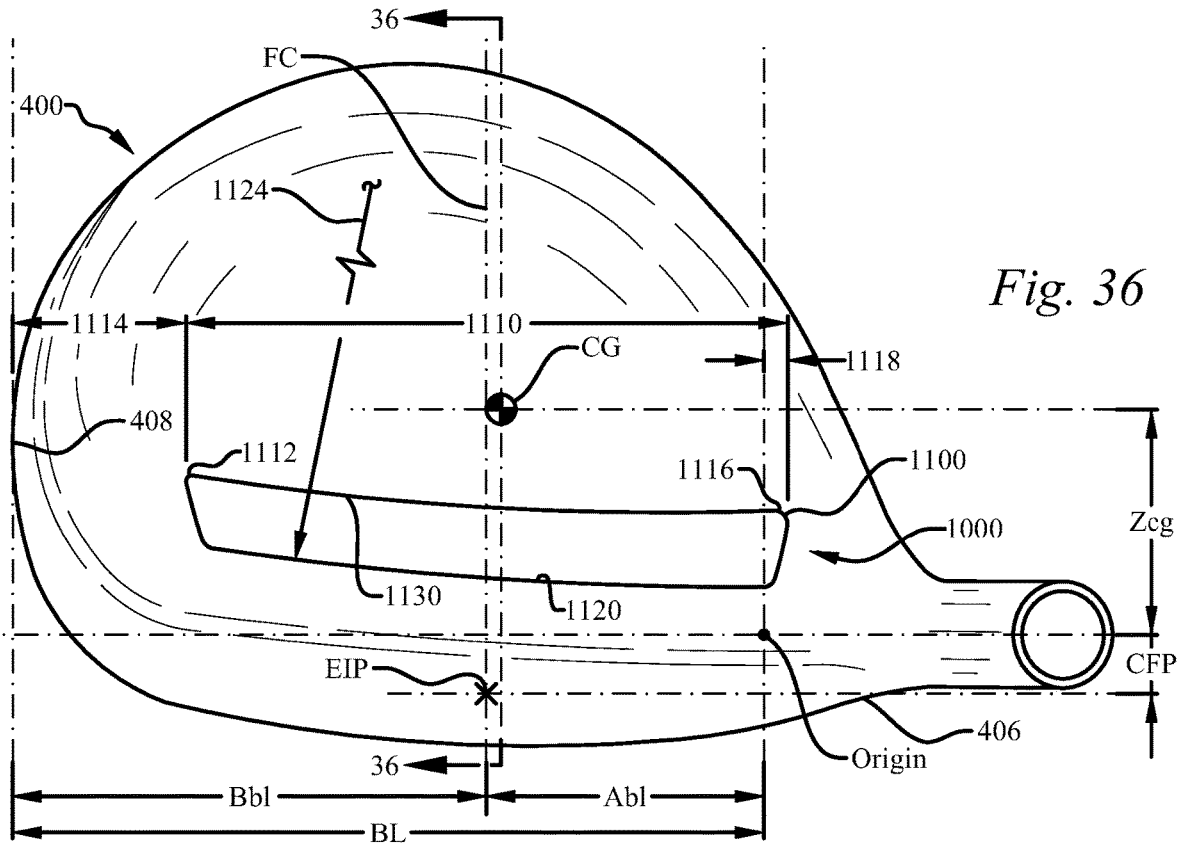

Fig. 36

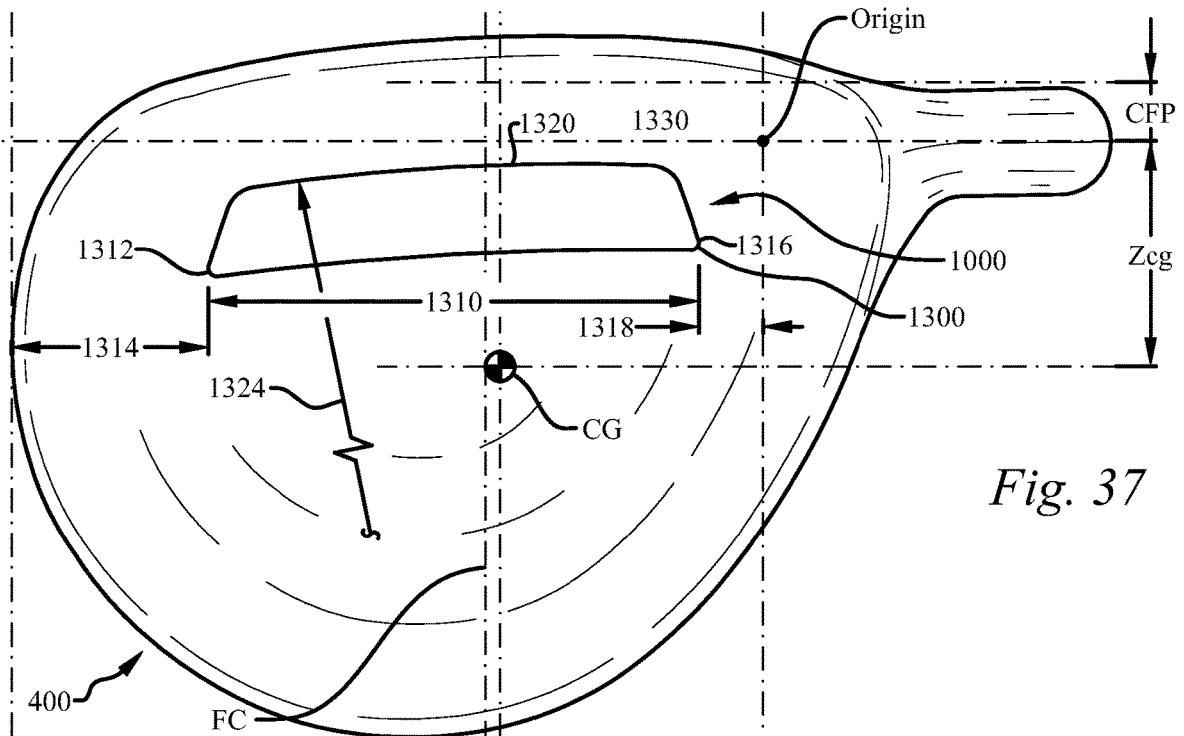

Fig. 37

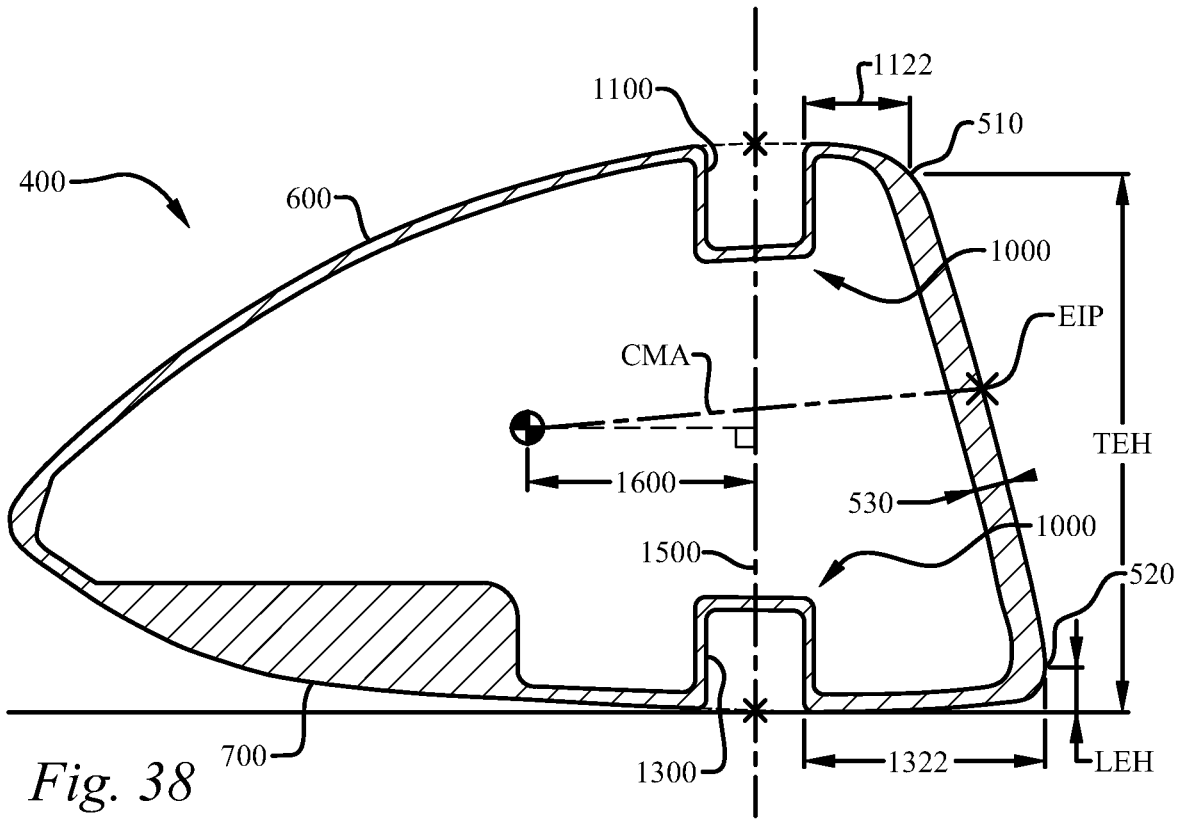

Fig. 38

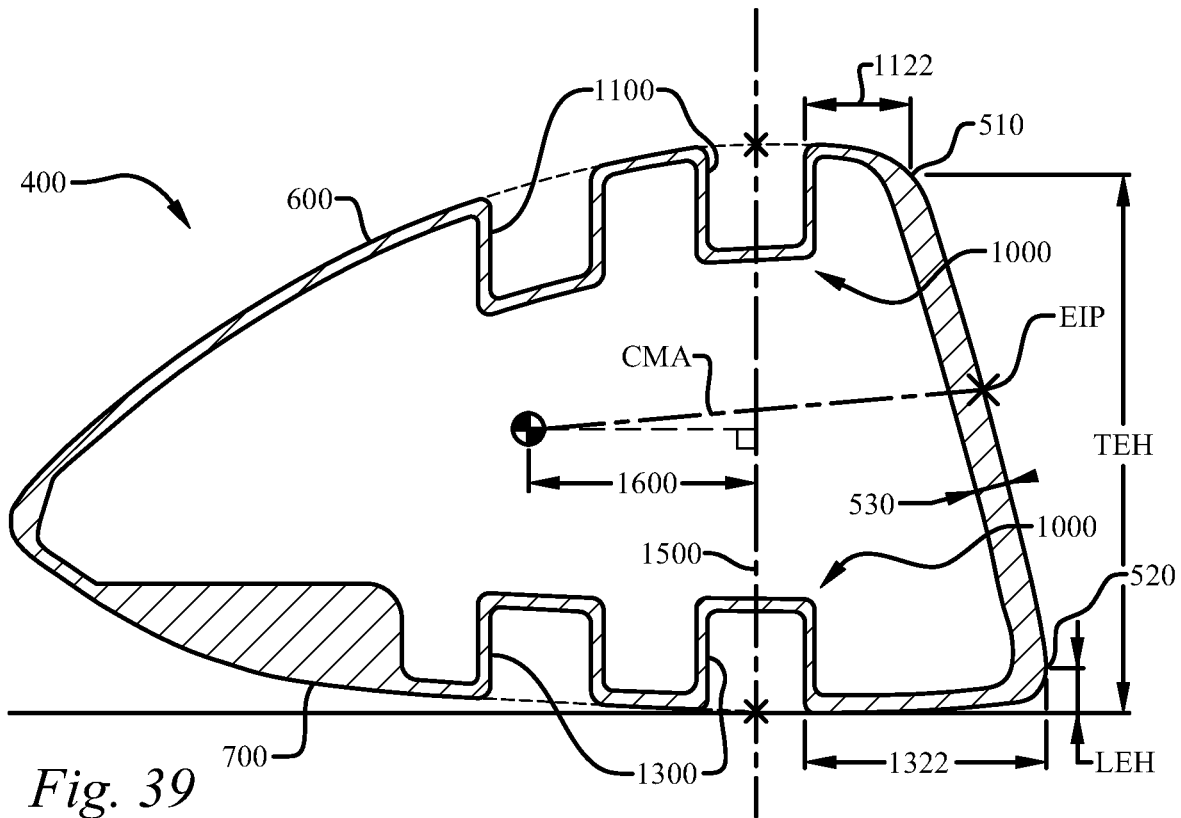

Fig. 39

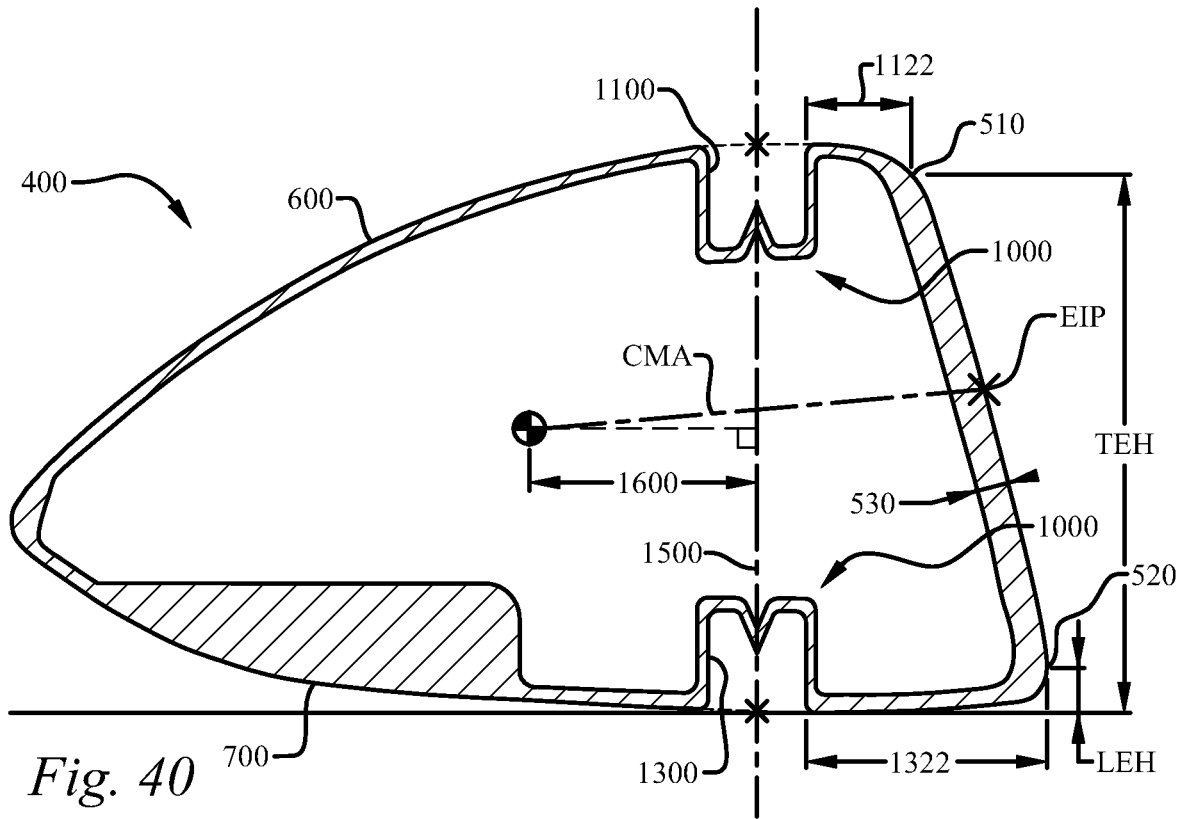

Fig. 40

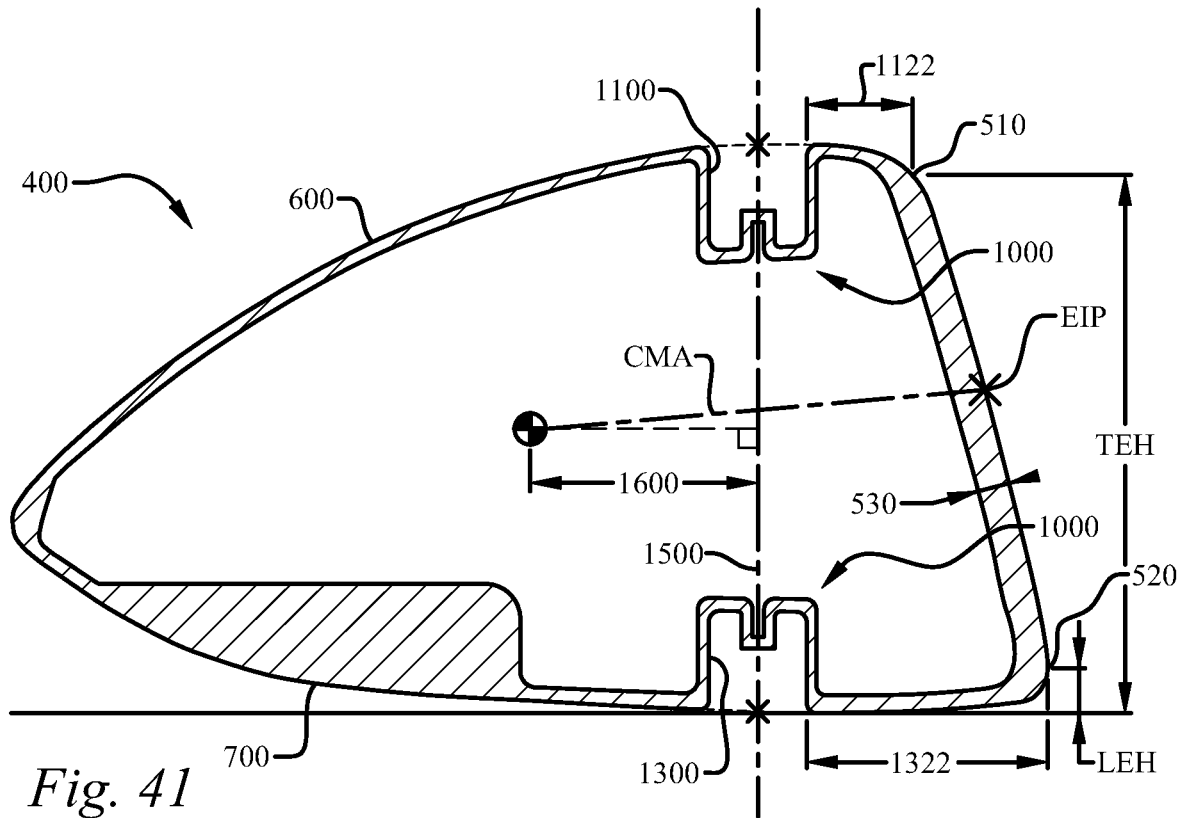

Fig. 41

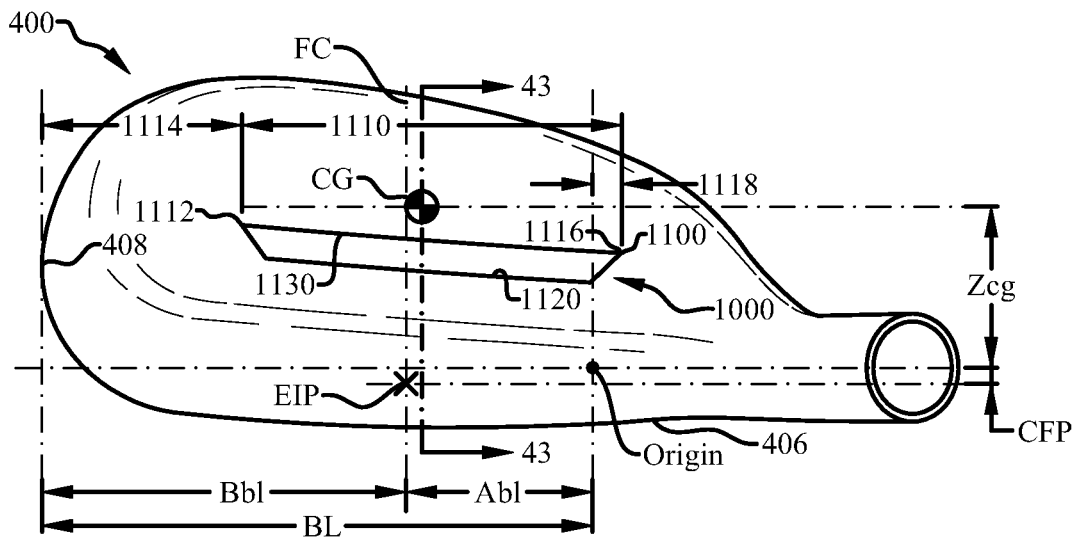

Fig. 42

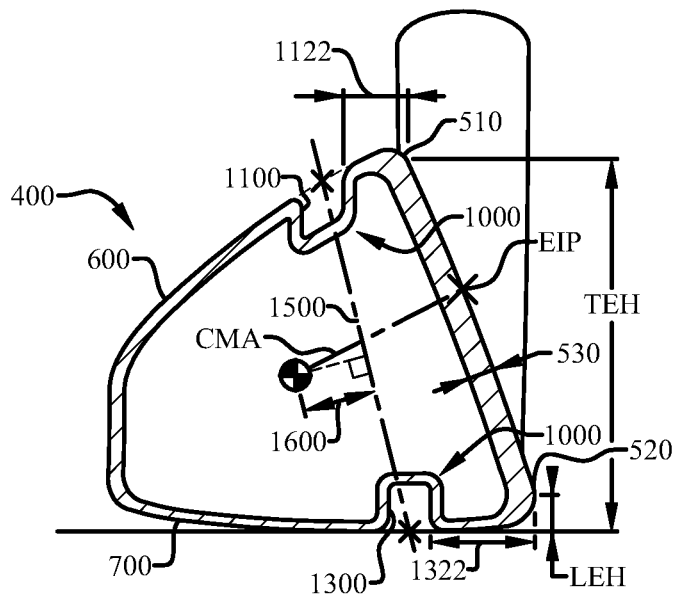

Fig. 43

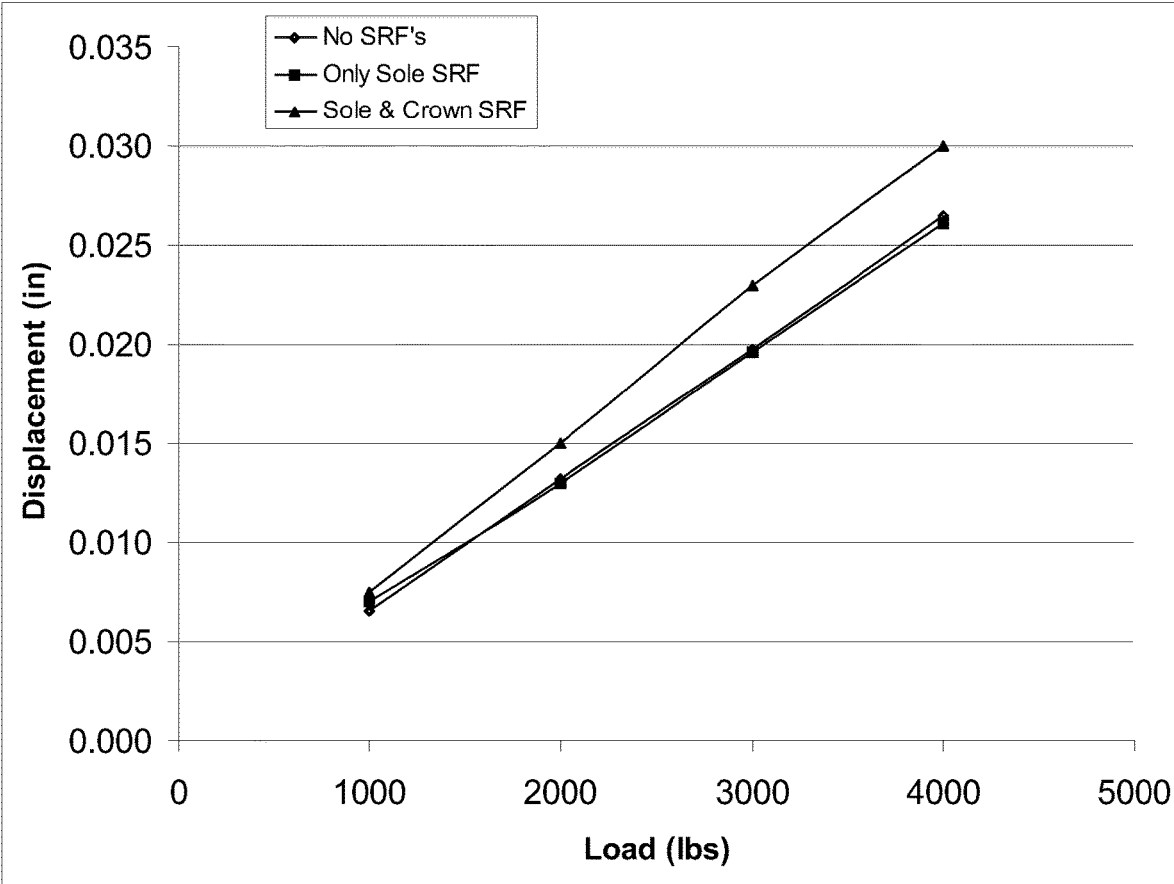

Fig. 44

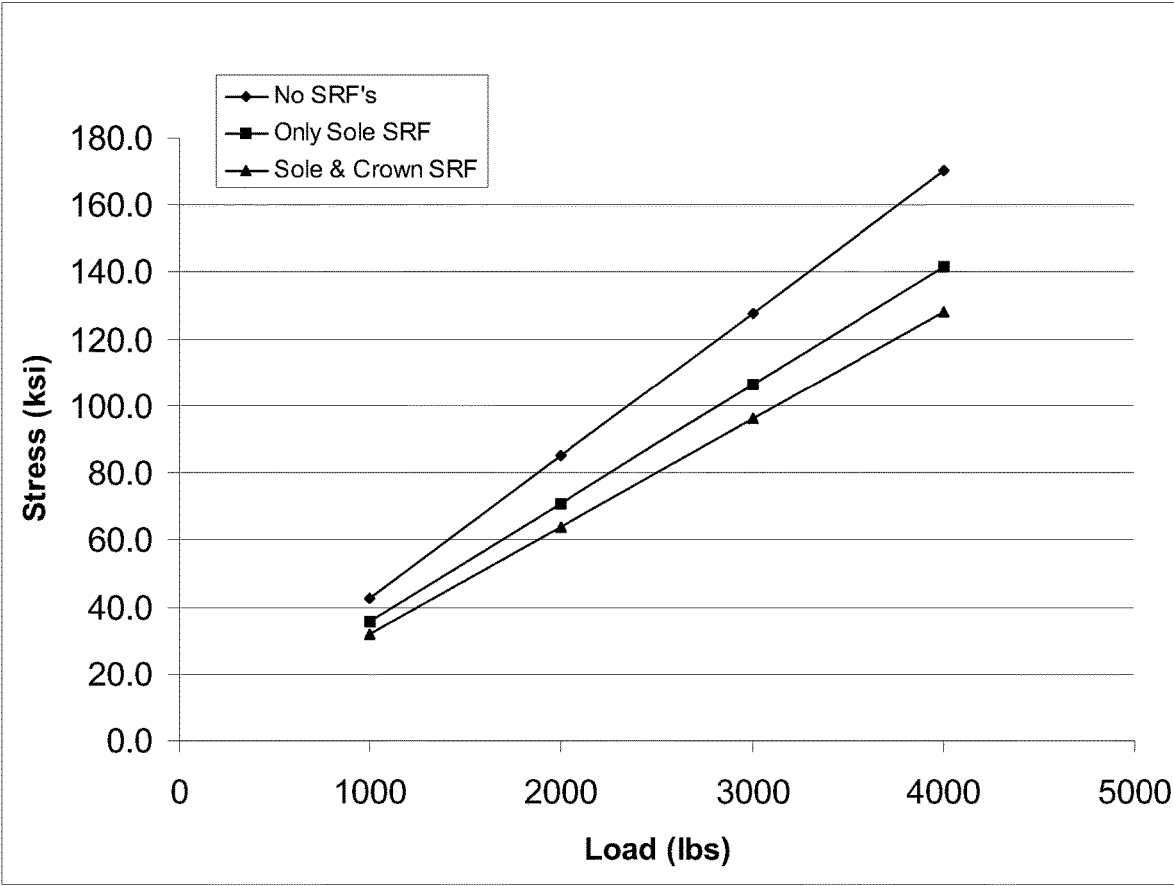

Fig. 45

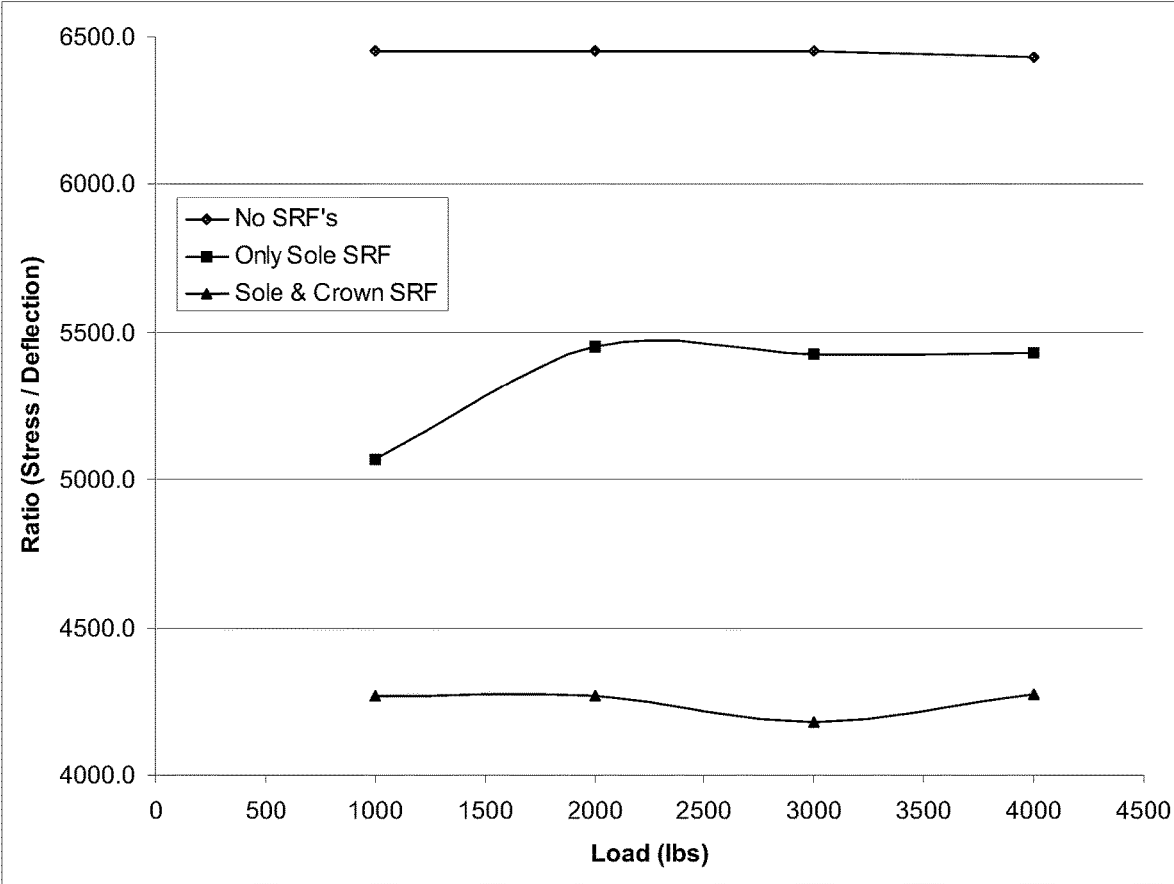

Fig. 46

1

MULTI-MATERIAL IRON-TYPE GOLF CLUB HEAD**CROSS-REFERENCE TO RELATED APPLICATIONS**

This application is a continuation of U.S. nonprovisional application Ser. No. 16/422,819, filed on May 24, 2019, which is a continuation of U.S. nonprovisional application Ser. No. 15/955,775, filed on Apr. 18, 2018, now U.S. Pat. No. 10,300,350, which is a continuation of U.S. nonprovisional application Ser. No. 15/389,505, filed on Dec. 23, 2016, now U.S. Pat. No. 9,950,222, which is a continuation of nonprovisional application Ser. No. 14/873,477, filed on Oct. 2, 2015, now U.S. Pat. No. 9,566,479, which is a continuation of nonprovisional application Ser. No. 14/256,005, filed on Apr. 18, 2014, now U.S. Pat. No. 9,168,428, which is a continuation of U.S. nonprovisional application Ser. No. 13/949,586, filed on Jul. 24, 2013, now U.S. Pat. No. 8,721,471, which is a continuation of U.S. nonprovisional application Ser. No. 13/543,921, now U.S. Pat. No. 8,517,860, filed on Jul. 9, 2012, which is a continuation of U.S. nonprovisional application Ser. No. 13/324,093, now U.S. Pat. No. 8,241,143, filed on Dec. 13, 2011, which is a continuation of U.S. nonprovisional application Ser. No. 12/791,025, now U.S. Pat. No. 8,235,844, filed on Jun. 1, 2010, all of which is incorporated by reference as if completely written herein.

STATEMENT REGARDING FEDERALLY SPONSORED RESEARCH OR DEVELOPMENT

This invention was not made as part of a federally sponsored research or development project.

TECHNICAL FIELD

The present invention relates to the field of golf clubs, namely hollow golf club heads. The present invention is a hollow golf club head characterized by a stress reducing feature that includes a crown located stress reducing feature and a sole located stress reducing feature.

BACKGROUND OF THE INVENTION

The impact associated with a golf club head, often moving in excess of 100 miles per hour, impacting a stationary golf ball results in a tremendous force on the face of the golf club head, and accordingly a significant stress on the face. It is desirable to reduce the peak stress experienced by the face and to selectively distribute the force of impact to other areas of the golf club head where it may be more advantageously utilized.

SUMMARY OF INVENTION

In its most general configuration, the present invention advances the state of the art with a variety of new capabilities and overcomes many of the shortcomings of prior methods in new and novel ways. In its most general sense, the present invention overcomes the shortcomings and limitations of the prior art in any of a number of generally effective configurations.

The present golf club incorporating a stress reducing feature including a crown located SRF, short for stress reducing feature, located on the crown of the club head and a sole located SRF located on the sole of the club head. The

2

location and size of the SRFs, and their relationship to one another, play a significant role in reducing the peak stress seen on the golf club's face during an impact with a golf ball, as well as selectively increasing deflection of the face.

Numerous variations, modifications, alternatives, and alterations of the various preferred embodiments, processes, and methods may be used alone or in combination with one another as will become more readily apparent to those with skill in the art with reference to the following detailed description of the preferred embodiments and the accompanying figures and drawings.

BRIEF DESCRIPTION OF THE DRAWINGS

Without limiting the scope of the present invention as claimed below and referring now to the drawings and figures:

FIG. 1 shows a front elevation view of an embodiment of the present invention, not to scale;

FIG. 2 shows a top plan view of an embodiment of the present invention, not to scale;

FIG. 3 shows a front elevation view of an embodiment of the present invention, not to scale;

FIG. 4 shows a toe side elevation view of an embodiment of the present invention, not to scale;

FIG. 5 shows a top plan view of an embodiment of the present invention, not to scale;

FIG. 6 shows a toe side elevation view of an embodiment of the present invention, not to scale;

FIG. 7 shows a front elevation view of an embodiment of the present invention, not to scale;

FIG. 8 shows a toe side elevation view of an embodiment of the present invention, not to scale;

FIG. 9 shows a front elevation view of an embodiment of the present invention, not to scale;

FIG. 10 shows a front elevation view of an embodiment of the present invention, not to scale;

FIG. 11 shows a front elevation view of an embodiment of the present invention, not to scale;

FIG. 12 shows a front elevation view of an embodiment of the present invention, not to scale;

FIG. 13 shows a front elevation view of an embodiment of the present invention, not to scale;

FIG. 14 shows a top plan view of an embodiment of the present invention, not to scale;

FIG. 15 shows a front elevation view of an embodiment of the present invention, not to scale;

FIG. 16 shows a top plan view of an embodiment of the present invention, not to scale;

FIG. 17 shows a top plan view of an embodiment of the present invention, not to scale;

FIG. 18 shows a top plan view of an embodiment of the present invention, not to scale;

FIG. 19 shows a front elevation view of an embodiment of the present invention, not to scale;

FIG. 20 shows a toe side elevation view of an embodiment of the present invention, not to scale;

FIG. 21 shows a front elevation view of an embodiment of the present invention, not to scale;

FIG. 22 shows a top plan view of an embodiment of the present invention, not to scale;

FIG. 23 shows a bottom plan view of an embodiment of the present invention, not to scale;

FIG. 24 shows a partial cross-sectional view of an embodiment of the present invention, not to scale;

FIG. 25 shows a partial cross-sectional view of an embodiment of the present invention, not to scale;

FIG. 26 shows a partial cross-sectional view of an embodiment of the present invention, not to scale;

FIG. 27 shows a partial cross-sectional view of an embodiment of the present invention, not to scale;

FIG. 28 shows a partial cross-sectional view of an embodiment of the present invention, not to scale;

FIG. 29 shows a partial cross-sectional view of an embodiment of the present invention, not to scale;

FIG. 30 shows a top plan view of an embodiment of the present invention, not to scale;

FIG. 31 shows a bottom plan view of an embodiment of the present invention, not to scale;

FIG. 32 shows a top plan view of an embodiment of the present invention, not to scale;

FIG. 33 shows a bottom plan view of an embodiment of the present invention, not to scale;

FIG. 34 shows a partial cross-sectional view of an embodiment of the present invention, not to scale;

FIG. 35 shows a partial cross-sectional view of an embodiment of the present invention, not to scale;

FIG. 36 shows a top plan view of an embodiment of the present invention, not to scale;

FIG. 37 shows a bottom plan view of an embodiment of the present invention, not to scale;

FIG. 38 shows a partial cross-sectional view of an embodiment of the present invention, not to scale;

FIG. 39 shows a partial cross-sectional view of an embodiment of the present invention, not to scale;

FIG. 40 shows a partial cross-sectional view of an embodiment of the present invention, not to scale;

FIG. 41 shows a partial cross-sectional view of an embodiment of the present invention, not to scale;

FIG. 42 shows a top plan view of an embodiment of the present invention, not to scale;

FIG. 43 shows a partial cross-sectional view of an embodiment of the present invention, not to scale;

FIG. 44 shows a graph of face displacement versus load;

FIG. 45 shows a graph of peak stress on the face versus load; and

FIG. 46 shows a graph of the stress-to-deflection ratio versus load.

These drawings are provided to assist in the understanding of the exemplary embodiments of the present golf club as described in more detail below and should not be construed as unduly limiting the golf club. In particular, the relative spacing, positioning, sizing and dimensions of the various elements illustrated in the drawings are not drawn to scale and may have been exaggerated, reduced or otherwise modified for the purpose of improved clarity. Those of ordinary skill in the art will also appreciate that a range of alternative configurations have been omitted simply to improve the clarity and reduce the number of drawings.

DETAILED DESCRIPTION OF THE INVENTION

The hollow golf club of the present invention enables a significant advance in the state of the art. The preferred embodiments of the golf club accomplish this by new and novel methods that are configured in unique and novel ways and which demonstrate previously unavailable, but preferred and desirable capabilities. The description set forth below in connection with the drawings is intended merely as a description of the presently preferred embodiments of the golf club, and is not intended to represent the only form in which the present golf club may be constructed or utilized. The description sets forth the designs, functions, means, and

methods of implementing the golf club in connection with the illustrated embodiments. It is to be understood, however, that the same or equivalent functions and features may be accomplished by different embodiments that are also intended to be encompassed within the spirit and scope of the claimed golf club head.

In order to fully appreciate the present disclosed golf club some common terms must be defined for use herein. First, one of skill in the art will know the meaning of “center of gravity,” referred to herein as CG, from an entry level course on the mechanics of solids. With respect to wood-type golf clubs, hybrid golf clubs, and hollow iron type golf clubs, which are may have non-uniform density, the CG is often thought of as the intersection of all the balance points of the club head. In other words, if you balance the head on the face and then on the sole, the intersection of the two imaginary lines passing straight through the balance points would define the point referred to as the CG.

It is helpful to establish a coordinate system to identify and discuss the location of the CG. In order to establish this coordinate system one must first identify a ground plane (GP) and a shaft axis (SA). First, the ground plane (GP) is the horizontal plane upon which a golf club head rests, as seen best in a front elevation view of a golf club head looking at the face of the golf club head, as seen in FIG. 1. Secondly, the shaft axis (SA) is the axis of a bore in the golf club head that is designed to receive a shaft. Some golf club heads have an external hosel that contains a bore for receiving the shaft such that one skilled in the art can easily appreciate the shaft axis (SA), while other “hosel-less” golf clubs have an internal bore that receives the shaft that nonetheless defines the shaft axis (SA). The shaft axis (SA) is fixed by the design of the golf club head and is also illustrated in FIG. 1.

Now, the intersection of the shaft axis (SA) with the ground plane (GP) fixes an origin point, labeled “origin” in FIG. 1, for the coordinate system. While it is common knowledge in the industry, it is worth noting that the right side of the club head seen in FIG. 1, the side nearest the bore in which the shaft attaches, is the “heel” side of the golf club head; and the opposite side, the left side in FIG. 1, is referred to as the “toe” side of the golf club head. Additionally, the portion of the golf club head that actually strikes a golf ball is referred to as the face of the golf club head and is commonly referred to as the front of the golf club head; whereas the opposite end of the golf club head is referred to as the rear of the golf club head and/or the trailing edge.

A three dimensional coordinate system may now be established from the origin with the Y-direction being the vertical direction from the origin; the X-direction being the horizontal direction perpendicular to the Y-direction and wherein the X-direction is parallel to the face of the golf club head in the natural resting position, also known as the design position; and the Z-direction is perpendicular to the X-direction wherein the Z-direction is the direction toward the rear of the golf club head. The X, Y, and Z directions are noted on a coordinate system symbol in FIG. 1. It should be noted that this coordinate system is contrary to the traditional right-hand rule coordinate system; however it is preferred so that the center of gravity may be referred to as having all positive coordinates.

Now, with the origin and coordinate system defined, the terms that define the location of the CG may be explained. One skilled in the art will appreciate that the CG of a hollow golf club head such as the wood-type golf club head illustrated in FIG. 2 will be behind the face of the golf club head. The distance behind the origin that the CG is located is

5

referred to as Z_{cg} , as seen in FIG. 2. Similarly, the distance above the origin that the CG is located is referred to as Y_{cg} , as seen in FIG. 3. Lastly, the horizontal distance from the origin that the CG is located is referred to as X_{cg} , also seen in FIG. 3. Therefore, the location of the CG may be easily identified by reference to X_{cg} , Y_{cg} , and Z_{cg} .

The moment of inertia of the golf club head is a key ingredient in the playability of the club. Again, one skilled in the art will understand what is meant by moment of inertia with respect to golf club heads; however it is helpful to define two moment of inertia components that will be commonly referred to herein. First, $MOIx$ is the moment of inertia of the golf club head around an axis through the CG, parallel to the X-axis, labeled in FIG. 4. $MOIx$ is the moment of inertia of the golf club head that resists lofting and delofting moments induced by ball strikes high or low on the face. Secondly, $MOIy$ is the moment of the inertia of the golf club head around an axis through the CG, parallel to the Y-axis, labeled in FIG. 5. $MOIy$ is the moment of inertia of the golf club head that resists opening and closing moments induced by ball strikes towards the toe side or heel side of the face.

Continuing with the definitions of key golf club head dimensions, the "front-to-back" dimension, referred to as the FB dimension, is the distance from the furthest forward point at the leading edge of the golf club head to the furthest rearward point at the rear of the golf club head, i.e. the trailing edge, as seen in FIG. 6. The "heel-to-toe" dimension, referred to as the HT dimension, is the distance from the point on the surface of the club head on the toe side that is furthest from the origin in the X-direction, to the point on the surface of the golf club head on the heel side that is 0.875" above the ground plane and furthest from the origin in the negative X-direction, as seen in FIG. 7.

A key location on the golf club face is an engineered impact point (EIP). The engineered impact point (EIP) is important in that it helps define several other key attributes of the present golf club head. The engineered impact point (EIP) is generally thought of as the point on the face that is the ideal point at which to strike the golf ball. Generally, the score lines on golf club heads enable one to easily identify the engineered impact point (EIP) for a golf club. In the embodiment of FIG. 9, the first step in identifying the engineered impact point (EIP) is to identify the top score line (TSL) and the bottom score line (BSL). Next, draw an imaginary line (IL) from the midpoint of the top score line (TSL) to the midpoint of the bottom score line (BSL). This imaginary line (IL) will often not be vertical since many score line designs are angled upward toward the toe when the club is in the natural position. Next, as seen in FIG. 10, the club must be rotated so that the top score line (TSL) and the bottom score line (BSL) are parallel with the ground plane (GP), which also means that the imaginary line (IL) will now be vertical. In this position, the leading edge height (LEH) and the top edge height (TEH) are measured from the ground plane (GP). Next, the face height is determined by subtracting the leading edge height (LEH) from the top edge height (TEH). The face height is then divided in half and added to the leading edge height (LEH) to yield the height of the engineered impact point (EIP). Continuing with the club head in the position of FIG. 10, a spot is marked on the imaginary line (IL) at the height above the ground plane (GP) that was just calculated. This spot is the engineered impact point (EIP).

The engineered impact point (EIP) may also be easily determined for club heads having alternative score line configurations. For instance, the golf club head of FIG. 11

6

does not have a centered top score line. In such a situation, the two outermost score lines that have lengths within 5% of one another are then used as the top score line (TSL) and the bottom score line (BSL). The process for determining the location of the engineered impact point (EIP) on the face is then determined as outlined above. Further, some golf club heads have non-continuous score lines, such as that seen at the top of the club head face in FIG. 12. In this case, a line is extended across the break between the two top score line sections to create a continuous top score line (TSL). The newly created continuous top score line (TSL) is then bisected and used to locate the imaginary line (IL). Again, then the process for determining the location of the engineered impact point (EIP) on the face is determined as outlined above.

The engineered impact point (EIP) may also be easily determined in the rare case of a golf club head having an asymmetric score line pattern, or no score lines at all. In such embodiments the engineered impact point (EIP) shall be determined in accordance with the USGA "Procedure for Measuring the Flexibility of a Golf Clubhead," Revision 2.0, Mar. 25, 2005, which is incorporated herein by reference. This USGA procedure identifies a process for determining the impact location on the face of a golf club that is to be tested, also referred therein as the face center. The USGA procedure utilizes a template that is placed on the face of the golf club to determine the face center. In these limited cases of asymmetric score line patterns, or no score lines at all, this USGA face center shall be the engineered impact point (EIP) that is referenced throughout this application.

The engineered impact point (EIP) on the face is an important reference to define other attributes of the present golf club head. The engineered impact point (EIP) is generally shown on the face with rotated crosshairs labeled EIP. The precise location of the engineered impact point (EIP) can be identified via the dimensions X_{eip} , Y_{eip} , and Z_{eip} , as illustrated in FIGS. 22-24. The X coordinate X_{eip} is measured in the same manner as X_{cg} , the Y coordinate Y_{eip} is measured in the same manner as Y_{cg} , and the Z coordinate Z_{eip} is measured in the same manner as Z_{cg} , except that Z_{eip} is always a positive value regardless of whether it is in front of the origin point or behind the origin point.

One important dimension that utilizes the engineered impact point (EIP) is the center face progression (CFP), seen in FIGS. 8 and 14. The center face progression (CFP) is a single dimension measurement and is defined as the distance in the Z-direction from the shaft axis (SA) to the engineered impact point (EIP). A second dimension that utilizes the engineered impact point (EIP) is referred to as a club moment arm (CMA). The CMA is the two dimensional distance from the CG of the club head to the engineered impact point (EIP) on the face, as seen in FIG. 8. Thus, with reference to the coordinate system shown in FIG. 1, the club moment arm (CMA) includes a component in the Z-direction and a component in the Y-direction, but ignores any difference in the X-direction between the CG and the engineered impact point (EIP). Thus, the club moment arm (CMA) can be thought of in terms of an impact vertical plane passing through the engineered impact point (EIP) and extending in the Z-direction. First, one would translate the CG horizontally in the X-direction until it hits the impact vertical plane. Then, the club moment arm (CMA) would be the distance from the projection of the CG on the impact vertical plane to the engineered impact point (EIP). The club moment arm (CMA) has a significant impact on the launch angle and the spin of the golf ball upon impact.

Another important dimension in golf club design is the club head blade length (BL), seen in FIG. 13 and FIG. 14. The blade length (BL) is the distance from the origin to a point on the surface of the club head on the toe side that is furthest from the origin in the X-direction. The blade length (BL) is composed of two sections, namely the heel blade length section (Abl) and the toe blade length section (Bbl). The point of delineation between these two sections is the engineered impact point (EIP), or more appropriately, a vertical line, referred to as a face centerline (FC), extending through the engineered impact point (EIP), as seen in FIG. 13, when the golf club head is in the normal resting position, also referred to as the design position.

Further, several additional dimensions are helpful in understanding the location of the CG with respect to other points that are essential in golf club engineering. First, a CG angle (CGA) is the one dimensional angle between a line connecting the CG to the origin and an extension of the shaft axis (SA), as seen in FIG. 14. The CG angle (CGA) is measured solely in the X-Z plane and therefore does not account for the elevation change between the CG and the origin, which is why it is easiest understood in reference to the top plan view of FIG. 14.

Lastly, another important dimension in quantifying the present golf club only takes into consideration two dimensions and is referred to as the transfer distance (TD), seen in FIG. 17. The transfer distance (TD) is the horizontal distance from the CG to a vertical line extending from the origin; thus, the transfer distance (TD) ignores the height of the CG, or Ycg. Thus, using the Pythagorean Theorem from simple geometry, the transfer distance (TD) is the hypotenuse of a right triangle with a first leg being Xcg and the second leg being Zcg.

The transfer distance (TD) is significant in that it helps define another moment of inertia value that is significant to the present golf club. This new moment of inertia value is defined as the face closing moment of inertia, referred to as MOIfc, which is the horizontally translated (no change in Y-direction elevation) version of MOIy around a vertical axis that passes through the origin. MOIfc is calculated by adding MOIy to the product of the club head mass and the transfer distance (TD) squared. Thus,

$$\text{MOIfc} = \text{MOIy} + (\text{mass} * \text{TD})^2$$

The face closing moment (MOIfc) is important because it represents the resistance that a golfer feels during a swing when trying to bring the club face back to a square position for impact with the golf ball. In other words, as the golf swing returns the golf club head to its original position to impact the golf ball the face begins closing with the goal of being square at impact with the golf ball.

The presently disclosed hollow golf club incorporates stress reducing features unlike prior hollow type golf clubs. The hollow type golf club includes a shaft (200) having a proximal end (210) and a distal end (220); a grip (300) attached to the shaft proximal end (210); and a golf club head (100) attached at the shaft distal end (220), as seen in FIG. 21. The overall hollow type golf club has a club length of at least 36 inches and no more than 45 inches, as measure in accordance with USGA guidelines.

The golf club head (400) itself is a hollow structure that includes a face (500) positioned at a front portion (402) of the golf club head (400) where the golf club head (400) impacts a golf ball, a sole (700) positioned at a bottom portion of the golf club head (400), a crown (600) positioned at a top portion of the golf club head (400), and a skirt (800) positioned around a portion of a periphery of the golf club

head (400) between the sole (700) and the crown (800). The face (500), sole (700), crown (600), and skirt (800) define an outer shell that further defines a head volume that is less than 300 cubic centimeters for the golf club head (400). Additionally, the golf club head (400) has a rear portion (404) opposite the face (500). The rear portion (404) includes the trailing edge of the golf club head (400), as is understood by one with skill in the art. The face (500) has a loft (L) of at least 12 degrees and no more than 30 degrees, and the face (500) includes an engineered impact point (EIP) as defined above. One skilled in the art will appreciate that the skirt (800) may be significant at some areas of the golf club head (400) and virtually nonexistent at other areas; particularly at the rear portion (404) of the golf club head (400) where it is not uncommon for it to appear that the crown (600) simply wraps around and becomes the sole (700).

The golf club head (100) includes a bore having a center that defines a shaft axis (SA) that intersects with a horizontal ground plane (GP) to define an origin point, as previously explained. The bore is located at a heel side (406) of the golf club head (400) and receives the shaft distal end (220) for attachment to the golf club head (400). The golf club head (100) also has a toe side (408) located opposite of the heel side (406). The presently disclosed golf club head (400) has a club head mass of less than 270 grams, which combined with the previously disclosed loft, club head volume, and club length establish that the presently disclosed golf club is directed to a hollow golf club such as a fairway wood, hybrid, or hollow iron.

The golf club head (400) includes a stress reducing feature (1000) including a crown located SRF (1100) located on the crown (600), seen in FIG. 22, and a sole located SRF (1300) located on the sole (700), seen in FIG. 23. As seen in FIGS. 22 and 25, the crown located SRF (1100) has a CSRF length (1110) between a CSRF toe-most point (1112) and a CSRF heel-most point (1116), a CSRF leading edge (1120), a CSRF trailing edge (1130), a CSRF width (1140), and a CSRF depth (1150). Similarly, as seen in FIGS. 23 and 25, the sole located SRF (1300) has a SSRF length (1310) between a SSRF toe-most point (1312) and a SSRF heel-most point (1316), a SSRF leading edge (1320), a SSRF trailing edge (1330), a SSRF width (1340), and a SSRF depth (1350).

With reference now to FIG. 24, a SRF connection plane (1500) passes through a portion of the crown located SRF (1100) and the sole located SRF (1300). To locate the SRF connection plane (1500) a vertical section is taken through the club head (400) in a front-to-rear direction, perpendicular to a vertical plane created by the shaft axis (SA); such a section is seen in FIG. 24. Then a crown SRF midpoint of the crown located SRF (1100) is determined at a location on a crown imaginary line following the natural curvature of the crown (600). The crown imaginary line is illustrated in FIG. 24 with a broken, or hidden, line connecting the CSRF leading edge (1120) to the CSRF trailing edge (1130), and the crown SRF midpoint is illustrated with an X. Similarly, a sole SRF midpoint of the sole located SRF (1300) is determined at a location on a sole imaginary line following the natural curvature of the sole (700). The sole imaginary line is illustrated in FIG. 24 with a broken, or hidden, line connecting the SSRF leading edge (1320) to the SSRF trailing edge (1330), and the sole SRF midpoint is illustrated with an X. Finally, the SRF connection plane (1500) is determined at a location on a sole imaginary line following the natural curvature of the sole (700). The sole imaginary line is illustrated in FIG. 24 with a broken, or hidden, line connecting the SSRF leading edge (1320) to the SSRF trailing edge (1330), and the sole SRF midpoint is illustrated with an X. While the SRF connection plane (1500) is a plane in the heel-to-toe direction that passes through both the crown SRF midpoint and the sole SRF midpoint, as seen in FIG. 24. While the SRF connection plane (1500) illustrated in FIG. 24 is approximately vertical, the orientation of

the SRF connection plane (1500) depends on the locations of the crown located SRF (1100) and the sole located SRF (1300) and may be angled toward the face, as seen in FIG. 26, or angled away from the face, as seen in FIG. 27.

The SRF connection plane (1500) is oriented at a connection plane angle (1510) from the vertical, seen in FIGS. 26 and 27, which aids in defining the location of the crown located SRF (1100) and the sole located SRF (1300). In one particular embodiment the crown located SRF (1100) and the sole located SRF (1300) are not located vertically directly above and below one another; rather, the connection plane angle (1510) is greater than zero and less than ninety percent of a loft (L) of the club head (400), as seen in FIG. 26. The sole located SRF (1300) could likewise be located in front of, i.e. toward the face (500), the crown located SRF (1100) and still satisfy the criteria of this embodiment; namely, that the connection plane angle (1510) is greater than zero and less than ninety percent of a loft of the club head (400).

In an alternative embodiment, seen in FIG. 27, the SRF connection plane (1500) is oriented at a connection plane angle (1510) from the vertical and the connection plane angle (1510) is at least ten percent greater than a loft (L) of the club head (400). The crown located SRF (1100) could likewise be located in front of, i.e. toward the face (500), the sole located SRF (1300) and still satisfy the criteria of this embodiment; namely, that the connection plane angle (1510) is at least ten percent greater than a loft (L) of the club head (400). In an even further embodiment the SRF connection plane (1500) is oriented at a connection plane angle (1510) from the vertical and the connection plane angle (1510) is at least fifty percent greater than a loft (L) of the club head (400), but less than one hundred percent greater than the loft (L). These three embodiments recognize a unique relationship between the crown located SRF (1100) and the sole located SRF (1300) such that they are not vertically aligned with one another, while also not merely offset in a manner matching the loft (L) of the club head (400).

With reference now to FIGS. 30 and 31, in the event that a crown located SRF (1100) or a sole located SRF (1300), or both, do not exist at the location of the CG section, labeled as section 24-24 in FIG. 22, then the crown located SRF (1100) located closest to the front-to-rear vertical plane passing through the CG is selected. For example, as seen in FIG. 30 the right crown located SRF (1100) is nearer to the front-to-rear vertical CG plane than the left crown located SRF (1100). In other words the illustrated distance "A" is smaller for the right crown located SRF (1100). Next, the face centerline (FC) is translated until it passes through both the CSRF leading edge (1120) and the CSRF trailing edge (1130), as illustrated by broken line "B". Then, the midpoint of line "B" is found and labeled "C". Finally, imaginary line "D" is created that is perpendicular to the "B" line.

The same process is repeated for the sole located SRF (1300), as seen in FIG. 31. It is simply a coincidence that both the crown located SRF (1100) and the sole located SRF (1300) located closest to the front-to-rear vertical CG plane are both on the heel side (406) of the golf club head (400). The same process applies even when the crown located SRF (1100) and the sole located SRF (1300) located closest to the front-to-rear vertical CG plane are on opposites sides of the golf club head (400). Now, still referring to FIG. 31, the process first involves identifying that the right sole located SRF (1300) is nearer to the front-to-rear vertical CG plane than the left sole located SRF (1300). In other words the illustrated distance "E" is smaller for the heel-side sole located SRF (1300). Next, the face centerline (FC) is trans-

lated until it passes through both the SSRF leading edge (1320) and the SSRF trailing edge (1330), as illustrated by broken line "F". Then, the midpoint of line "F" is found and labeled "G". Finally, imaginary line "H" is created that is perpendicular to the "F" line. The plane passing through both the imaginary line "D" and imaginary line "H" is the SRF connection plane (1500).

Next, referring back to FIG. 24, a CG-to-plane offset (1600) is defined as the shortest distance from the center of gravity (CG) to the SRF connection plane (1500), regardless of the location of the CG. In one particular embodiment the CG-to-plane offset (1600) is at least twenty-five percent less than the club moment arm (CMA) and the club moment arm (CMA) is less than 1.3 inches. The locations of the crown located SRF (1100) and the sole located SRF (1300) described herein, and the associated variables identifying the location, are selected to preferably reduce the stress in the face (500) when impacting a golf ball while accommodating temporary flexing and deformation of the crown located SRF (1100) and sole located SRF (1300) in a stable manner in relation to the CG location, and/or origin point, while maintaining the durability of the face (500), the crown (600), and the sole (700). Experimentation and modeling has shown that both the crown located SRF (1100) and the sole located SRF (1300) are necessary to increase the deflection of the face (500), while also reduce the peak stress on the face (500) at impact with a golf ball. This reduction in stress allows a substantially thinner face to be utilized, permitting the weight savings to be distributed elsewhere in the club head (400). Further, the increased deflection of the face (500) facilitates improvements in the coefficient of restitution (COR) of the club head (400), particularly for club heads having a volume of 300 cc or less.

In fact, further embodiments even more precisely identify the location of the crown located SRF (1100) and the sole located SRF (1300) to achieve these objectives. For instance, in one further embodiment the CG-to-plane offset (1600) is at least twenty-five percent of the club moment arm (CMA) and less than seventy-five percent of the club moment arm (CMA). In still a further embodiment, the CG-to-plane offset (1600) is at least forty percent of the club moment arm (CMA) and less than sixty percent of the club moment arm (CMA).

Alternatively, another embodiment relates the location of the crown located SRF (1100) and the sole located SRF (1300) to the difference between the maximum top edge height (TEH) and the minimum lower edge (LEH), referred to as the face height, rather than utilizing the CG-to-plane offset (1600) variable as previously discussed. As such, two additional variables are illustrated in FIG. 24, namely the CSRF leading edge offset (1122) and the SSRF leading edge offset (1322). The CSRF leading edge offset (1122) is the distance from any point along the CSRF leading edge (1120) directly forward, in the Zcg direction, to the point at the top edge (510) of the face (500). Thus, the CSRF leading edge offset (1122) may vary along the length of the CSRF leading edge (1120), or it may be constant if the curvature of the CSRF leading edge (1120) matches the curvature of the top edge (510) of the face (500). Nonetheless, there will always be a minimum CSRF leading edge offset (1122) at the point along the CSRF leading edge (1120) that is the closest to the corresponding point directly in front of it on the face top edge (510), and there will be a maximum CSRF leading edge offset (1122) at the point along the CSRF leading edge (1120) that is the farthest from the corresponding point directly in front of it on the face top edge (510). Likewise, the SSRF leading edge offset (1322) is the distance from any

point along the SSRF leading edge (1320) directly forward, in the Zcg direction, to the point at the lower edge (520) of the face (500). Thus, the SSRF leading edge offset (1322) may vary along the length of the SSRF leading edge (1320), or it may be constant if the curvature of SSRF leading edge (1320) matches the curvature of the lower edge (520) of the face (500). Nonetheless, there will always be a minimum SSRF leading edge offset (1322) at the point along the SSRF leading edge (1320) that is the closest to the corresponding point directly in front of it on the face lower edge (520), and there will be a maximum SSRF leading edge offset (1322) at the point along the SSRF leading edge (1320) that is the farthest from the corresponding point directly in front of it on the face lower edge (520). Generally, the maximum CSRFB leading edge offset (1122) and the maximum SSRF leading edge offset (1322) will be less than seventy-five percent of the face height. For the purposes of this application and ease of definition, the face top edge (510) is the series of points along the top of the face (500) at which the vertical face roll becomes less than one inch, and similarly the face lower edge (520) is the series of points along the bottom of the face (500) at which the vertical face roll becomes less than one inch.

In this particular embodiment, the minimum CSRFB leading edge offset (1122) is less than the face height, while the minimum SSRF leading edge offset (1322) is at least two percent of the face height. In an even further embodiment, the maximum CSRFB leading edge offset (1122) is also less than the face height. Yet another embodiment incorporates a minimum CSRFB leading edge offset (1122) that is at least ten percent of the face height, and the minimum CSRFB width (1140) is at least fifty percent of the minimum CSRFB leading edge offset (1122). A still further embodiment more narrowly defines the minimum CSRFB leading edge offset (1122) as being at least twenty percent of the face height.

Likewise, many embodiments are directed to advantageous relationships of the sole located SRF (1300). For instance, in one embodiment, the minimum SSRF leading edge offset (1322) is at least ten percent of the face height, and the minimum SSRF width (1340) is at least fifty percent of the minimum SSRF leading edge offset (1322). Even further, another embodiment more narrowly defines the minimum SSRF leading edge offset (1322) as being at least twenty percent of the face height.

Still further building upon the relationships among the CSRFB leading edge offset (1122), the SSRF leading edge offset (1322), and the face height, one embodiment further includes an engineered impact point (EIP) having a Yeip coordinate such that the difference between Yeip and Ycg is less than 0.5 inches and greater than -0.5 inches; a Xeip coordinate such that the difference between Xeip and Xcg is less than 0.5 inches and greater than -0.5 inches; and a Zeip coordinate such that the total of Zeip and Zcg is less than 2.0 inches. These relationships among the location of the engineered impact point (EIP) and the location of the center of gravity (CG) in combination with the leading edge locations of the crown located SRF (1100) and the sole located SRF (1300) promote stability at impact, while accommodating desirable deflection of the SRFs (1100, 1300) and the face (500), while also maintaining the durability of the club head (400) and reducing the peak stress experienced in the face (500).

While the location of the crown located SRF (1100) and the sole located SRF (1300) is important in achieving these objectives, the size of the crown located SRF (1100) and the sole located SRF (1300) also plays a role. In one particular long blade length embodiment directed to fairway wood

type golf clubs and hybrid type golf clubs, illustrated in FIGS. 42 and 43, the golf club head (400) has a blade length (BL) of at least 3.0 inches with a heel blade length section (Abl) of at least 0.8 inches. In this embodiment, preferable results are obtained when the CSRFB length (1110) is at least as great as the heel blade length section (Abl), the SSRF length (1310) is at least as great as the heel blade length section (Abl), the maximum CSRFB depth (1150) is at least ten percent of the Ycg distance, and the maximum SSRF depth (1350) is at least ten percent of the Ycg distance, thereby permitting adequate compression and/or flexing of the crown located SRF (1100) and sole located SRF (1300) to significantly reduce the stress on the face (500) at impact. It should be noted at this point that the cross-sectional profile of the crown located SRF (1100) and the sole mounted SRF (1300) may include any number of shapes including, but not limited to, a box-shape, as seen in FIG. 24, a smooth U-shape, as seen in FIG. 28, and a V-shape, as seen in FIG. 29. Further, the crown located SRF (1100) and the sole located SRF (1300) may include reinforcement areas as seen in FIGS. 40 and 41 to further selectively control the deformation of the SRFs (1100, 1300). Additionally, the CSRFB length (1110) and the SSRF length (1310) are measured in the same direction as Xcg rather than along the curvature of the SRFs (1100, 1300), if curved.

The crown located SRF (1100) has a CSRFB wall thickness (1160) and sole located SRF (1300) has a SSRF wall thickness (1360), as seen in FIG. 25. In most embodiments the CSRFB wall thickness (1160) and the SSRF wall thickness (1360) will be at least 0.010 inches and no more than 0.150 inches. In particular embodiment has found that having the CSRFB wall thickness (1160) and the SSRF wall thickness (1360) in the range of ten percent to sixty percent of the face thickness (530) achieves the required durability while still providing desired stress reduction in the face (500) and deflection of the face (500). Further, this range facilitates the objectives while not have a dilutive effect, nor overly increasing the weight distribution of the club head (400) in the vicinity of the SRFs (1100, 1300).

Further, the terms maximum CSRFB depth (1150) and maximum SSRF depth (1350) are used because the depth of the crown located SRF (1100) and the depth of the sole located SRF (1300) need not be constant; in fact, they are likely to vary, as seen in FIGS. 32-35. Additionally, the end walls of the crown located SRF (1100) and the sole located SRF (1300) need not be distinct, as seen on the right and left side of the SRFs (1100, 1300) seen in FIG. 35, but may transition from the maximum depth back to the natural contour of the crown (600) or sole (700). The transition need not be smooth, but rather may be stepwise, compound, or any other geometry. In fact, the presence or absence of end walls is not necessary in determining the bounds of the claimed golf club. Nonetheless, a criteria needs to be established for identifying the location of the CSRFB toe-most point (1112), the CSRFB heel-most point (1116), the SSRF toe-most point (1312), and the SSRF heel-most point (1316); thus, when not identifiable via distinct end walls, these points occur where a deviation from the natural curvature of the crown (600) or sole (700) is at least ten percent of the maximum CSRFB depth (1150) or maximum SSRF depth (1350). In most embodiments a maximum CSRFB depth (1150) and a maximum SSRF depth (1350) of at least 0.100 inches and no more than 0.500 inches is preferred.

The CSRFB leading edge (1120) may be straight or may include a CSRFB leading edge radius of curvature (1124), as seen in FIG. 36. Likewise, the SSRF leading edge (1320)

may be straight or may include a SSRF leading edge radius of curvature (1324), as seen in FIG. 37. One particular embodiment incorporates both a curved CSRf leading edge (1120) and a curved SSRf leading edge (1320) wherein both the CSRf leading edge radius of curvature (1124) and the SSRf leading edge radius of curvature (1324) are within forty percent of the curvature of the bulge of the face (500). In an even further embodiment both the CSRf leading edge radius of curvature (1124) and the SSRf leading edge radius of curvature (1324) are within twenty percent of the curvature of the bulge of the face (500). These curvatures further aid in the controlled deflection of the face (500).

One particular embodiment, illustrated in FIGS. 32-35, has a CSRf depth (1150) that is less at the face centerline (FC) than at a point on the toe side (408) of the face centerline (FC) and at a point on the heel side (406) of the face centerline (FC), thereby increasing the potential deflection of the face (500) at the heel side (406) and the toe side (408), where the COR is generally lower than the USGA permitted limit. In another embodiment, the crown located SRF (1100) and the sole located SRF (1300) each have reduced depth regions, namely a CSRf reduced depth region (1152) and a SSRf reduced depth region (1352), as seen in FIG. 35. Each reduced depth region is characterized as a continuous region having a depth that is at least twenty percent less than the maximum depth for the particular SRF (1100, 1300). The CSRf reduced depth region (1152) has a CSRf reduced depth length (1154) and the SSRf reduced depth region (1352) has a SSRf reduced depth length (1354). In one particular embodiment, each reduced depth length (1154, 1354) is at least fifty percent of the heel blade length section (Abl). A further embodiment has the CSRf reduced depth region (1152) and the SSRf reduced depth region (1352) approximately centered about the face centerline (FC), as seen in FIG. 35. Yet another embodiment incorporates a design wherein the CSRf reduced depth length (1154) is at least thirty percent of the CSRf length (1110), and the SSRf reduced depth length (1354) is at least thirty percent of the SSRf length (1310). In addition to aiding in achieving the objectives set out above, the reduced depth regions (1152, 1352) may improve the life of the SRFs (1100, 1300) and reduce the likelihood of premature failure, while increasing the COR at desirable locations on the face (500).

As seen in FIG. 25, the crown located SRF (1100) has a CSRf cross-sectional area (1170) and the sole located SRF (1300) has a SSRf cross-sectional area (1370). The cross-sectional areas are measured in cross-sections that run from the front portion (402) to the rear portion (404) of the club head (400) in a vertical plane. Just as the cross-sectional profiles (1190, 1390) of FIGS. 28 and 29 may change throughout the CSRf length (1110) and the SSRf length (1310), the CSRf cross-sectional area (1170) and the SSRf cross-sectional area (1370) may also vary along the lengths (1110, 1310). In fact, in one particular embodiment, the CSRf cross-sectional area (1170) is less at the face centerline (FC) than at a point on the toe side (408) of the face centerline (FC) and a point on the heel side (406) of the face centerline (FC). Similarly, in another embodiment, the SSRf cross-sectional area (1370) is less at the face centerline than at a point on the toe side (408) of the face centerline (FC) and a point on the heel side (406) of the face centerline (FC); and yet a third embodiment incorporates both of the prior two embodiments related to the CSRf cross-sectional area (1170) and the SSRf cross-sectional area (1370). In one particular embodiment, the CSRf cross-sectional area (1170) and the SSRf cross-sectional area (1370) fall within

the range of 0.005 square inches to 0.375 square inches. Additionally, the crown located SRF (1100) has a CSRf volume and the sole located SRF (1300) has a SSRf volume. In one embodiment the combined CSRf volume and SSRf volume is at least 0.5 percent of the club head volume and less than 10 percent of the club head volume, as this range facilitates the objectives while not have a dilutive effect, nor overly increasing the weight distribution of the club head (400) in the vicinity of the SRFs (1100, 1300).

Now, in another separate embodiment seen in FIGS. 36 and 37, a CSRf origin offset (1118) is defined as the distance from the origin point to the CSRf heel-most point (1116) in the same direction as the Xcg distance such that the CSRf origin offset (1118) is a positive value when the CSRf heel-most point (1116) is located toward the toe side (408) of the golf club head (400) from the origin point, and the CSRf origin offset (1118) is a negative value when the CSRf heel-most point (1116) is located toward the heel side (406) of the golf club head (400) from the origin point. Similarly, in this embodiment, a SSRf origin offset (1318) is defined as the distance from the origin point to the SSRf heel-most point (1316) in the same direction as the Xcg distance such that the SSRf origin offset (1318) is a positive value when the SSRf heel-most point (1316) is located toward the toe side (408) of the golf club head (400) from the origin point, and the SSRf origin offset (1318) is a negative value when the SSRf heel-most point (1316) is located toward the heel side (406) of the golf club head (400) from the origin point.

In one particular embodiment, seen in FIG. 37, the SSRf origin offset (1318) is a positive value, meaning that the SSRf heel-most point (1316) stops short of the origin point. Further, yet another separate embodiment is created by combining the embodiment illustrated in FIG. 36 wherein the CSRf origin offset (1118) is a negative value, in other words the CSRf heel-most point (1116) extends past the origin point, and the magnitude of the CSRf origin offset (1118) is at least five percent of the heel blade length section (Abl). However, an alternative embodiment incorporates a CSRf heel-most point (1116) that does not extend past the origin point and therefore the CSRf origin offset (1118) is a positive value with a magnitude of at least five percent of the heel blade length section (Abl). In these particular embodiments, locating the CSRf heel-most point (1116) and the SSRf heel-most point (1316) such that they are no closer to the origin point than five percent of the heel blade length section (Abl) is desirable in achieving many of the objectives discussed herein over a wide range of ball impact locations.

Still further embodiments incorporate specific ranges of locations of the CSRf toe-most point (1112) and the SSRf toe-most point (1312) by defining a CSRf toe offset (1114) and a SSRf toe offset (1314), as seen in FIGS. 36 and 37. The CSRf toe offset (1114) is the distance measured in the same direction as the Xcg distance from the CSRf toe-most point (1112) to the most distant point on the toe side (408) of golf club head (400) in this direction, and likewise the SSRf toe offset (1314) is the distance measured in the same direction as the Xcg distance from the SSRf toe-most point (1312) to the most distant point on the toe side (408) of golf club head (400) in this direction. One particular embodiment found to produce preferred face stress distribution and compression and flexing of the crown located SRF (1100) and the sole located SRF (1300) incorporates a CSRf toe offset (1114) that is at least fifty percent of the heel blade length section (Abl) and a SSRf toe offset (1314) that is at least fifty percent of the heel blade length section (Abl). In

yet a further embodiment the CSRFB toe offset (1114) and the SSRFB toe offset (1314) are each at least fifty percent of a golf ball diameter; thus, the CSRFB toe offset (1114) and the SSRFB toe offset (1314) are each at 0.84 inches. These embodiments also minimally affect the integrity of the club head (400) as a whole, thereby ensuring the desired durability, particularly at the heel side (406) and the toe side (408) while still allowing for improved face deflection during off center impacts.

Even more embodiments now turn the focus to the size of the crown located SRF (1100) and the sole located SRF (1300). One such embodiment has a maximum CSRFB width (1140) that is at least ten percent of the Zcg distance, and the maximum SSRFB width (1340) is at least ten percent of the Zcg distance, further contributing to increased stability of the club head (400) at impact. Still further embodiments increase the maximum CSRFB width (1140) and the maximum SSRFB width (1340) such that they are each at least forty percent of the Zcg distance, thereby promoting deflection and selectively controlling the peak stresses seen on the face (500) at impact. An alternative embodiment relates the maximum CSRFB depth (1150) and the maximum SSRFB depth (1350) to the face height rather than the Zcg distance as discussed above. For instance, yet another embodiment incorporates a maximum CSRFB depth (1150) that is at least five percent of the face height, and a maximum SSRFB depth (1350) that is at least five percent of the face height. An even further embodiment incorporates a maximum CSRFB depth (1150) that is at least twenty percent of the face height, and a maximum SSRFB depth (1350) that is at least twenty percent of the face height, again, promoting deflection and selectively controlling the peak stresses seen on the face (500) at impact. In most embodiments a maximum CSRFB width (1140) and a maximum SSRFB width (1340) of at least 0.050 inches and no more than 0.750 inches is preferred.

Additional embodiments focus on the location of the crown located SRF (1100) and the sole located SRF (1300) with respect to a vertical plane defined by the shaft axis (SA) and the Xcg direction. One such embodiment has recognized improved stability and lower peak face stress when the crown located SRF (1100) and the sole located SRF (1300) are located behind the shaft axis plane. Further embodiments additionally define this relationship. In one such embodiment, the CSRFB leading edge (1120) is located behind the shaft axis plane a distance that is at least twenty percent of the Zcg distance. Yet another embodiment focuses on the location of the sole located SRF (1300) such that the SSRFB leading edge (1320) is located behind the shaft axis plane a distance that is at least ten percent of the Zcg distance. An even further embodiment focusing on the crown located SRF (1100) incorporates a CSRFB leading edge (1120) that is located behind the shaft axis plane a distance that is at least seventy-five percent of the Zcg distance. A similar embodiment directed to the sole located SRF (1300) has a SSRFB leading edge (1320) that is located behind the shaft axis plane a distance that is at least seventy-five percent of the Zcg distance. Similarly, the locations of the CSRFB leading edge (1120) and SSRFB leading edge (1320) behind the shaft axis plane may also be related to the face height instead of the Zcg distance discussed above. For instance, in one embodiment, the CSRFB leading edge (1120) is located a distance behind the shaft axis plane that is at least ten percent of the face height. A further embodiment focuses on the location of the sole located SRF (1300) such that the SSRFB leading edge (1320) is located behind the shaft axis plane a distance that is at least five percent of the Zcg distance. An even further embodiment focusing on both the

crown located SRF (1100) and the sole located SRF (1300) incorporates a CSRFB leading edge (1120) that is located behind the shaft axis plane a distance that is at least fifty percent of the face height, and a SSRFB leading edge (1320) that is located behind the shaft axis plane a distance that is at least fifty percent of the face height.

The club head (400) is not limited to a single crown located SRF (1100) and a single sole located SRF (1300). In fact, many embodiments incorporating multiple crown located SRFs (1100) and multiple sole located SRFs (1300) are illustrated in FIGS. 30, 31, and 39, showing that the multiple SRFs (1100, 1300) may be positioned beside one another in a heel-toe relationship, or may be positioned behind one another in a front-rear orientation. As such, one particular embodiment includes at least two crown located SRFs (1100) positioned on opposite sides of the engineered impact point (EIP) when viewed in a top plan view, as seen in FIG. 31, thereby further selectively increasing the COR and improving the peak stress on the face (500). Traditionally, the COR of the face (500) gets smaller as the measurement point is moved further away from the engineered impact point (EIP); and thus golfers that hit the ball toward the heel side (406) or toe side (408) of the a golf club head do not benefit from a high COR. As such, positioning of the two crown located SRFs (1100) seen in FIG. 30 facilitates additional face deflection for shots struck toward the heel side (406) or toe side (408) of the golf club head (400). Another embodiment, as seen in FIG. 31, incorporates the same principles just discussed into multiple sole located SRFs (1300).

The impact of a club head (400) and a golf ball may be simulated in many ways, both experimentally and via computer modeling. First, an experimental process will be explained because it is easy to apply to any golf club head and is free of subjective considerations. The process involves applying a force to the face (500) distributed over a 0.6 inch diameter centered about the engineered impact point (EIP). A force of 4000 lbf is representative of an approximately 100 mph impact between a club head (400) and a golf ball, and more importantly it is an easy force to apply to the face and reliably reproduce. The club head boundary condition consists of fixing the rear portion (404) of the club head (400) during application of the force. In other words, a club head (400) can easily be secured to a fixture within a material testing machine and the force applied. Generally, the rear portion (404) experiences almost no load during an actual impact with a golf ball, particularly as the "front-to-back" dimension (FB) increases. The peak deflection of the face (500) under the force is easily measured and is very close to the peak deflection seen during an actual impact, and the peak deflection has a linear correlation to the COR. A strain gauge applied to the face (500) can measure the actual stress. This experimental process takes only minutes to perform and a variety of forces may be applied to any club head (400); further, computer modeling of a distinct load applied over a certain area of a club face (500) is much quicker to simulate than an actual dynamic impact.

A graph of displacement versus load is illustrated in FIG. 44 for a club head having no stress reducing feature (1000), a club head (400) having only a sole located SRF (1300), and a club head (400) having both a crown located SRF (1100) and a sole located SRF (1300), at the following loads of 1000 lbf, 2000 lbf, 3000 lbf, and 4000 lbf, all of which are distributed over a 0.6 inch diameter area centered on the engineered impact point (EIP). The face thickness (530) was held a constant 0.090 inches for each of the three club heads.

The graph of FIG. 44 nicely illustrates that having only a sole located SRF (1300) has virtually no impact on the displacement of the face (500). However, incorporation of a crown located SRF (1100) and a sole located SRF (1300) as described herein increases face deflection by over 11% at the 4000 lbf load level, from a value of 0.027 inches to 0.030 inches. In one particular embodiment, the increased deflection resulted in an increase in the characteristic time (CT) of the club head from 187 microseconds to 248 microseconds. A graph of peak face stress versus load is illustrated in FIG. 45 for the same three variations just discussed with respect to FIG. 44. FIG. 45 nicely illustrates that incorporation of a crown located SRF (1100) and a sole located SRF (1300) as described herein reduces the peak face stress by almost 25% at the 4000 lbf load level, from a value of 170.4 ksi to 128.1 ksi. The stress reducing feature (1000) permits the use of a very thin face (500) without compromising the integrity of the club head (400). In fact, the face thickness (530) may vary from 0.050 inches, up to 0.120 inches.

Combining the information seen in FIGS. 44 and 45, a new ratio may be developed; namely, a stress-to-deflection ratio of the peak stress on the face to the displacement at a given load, as seen in FIG. 46. In one embodiment, the stress-to-deflection ratio is less than 5000 ksi per inch of deflection, wherein the approximate impact force is applied to the face (500) over a 0.6 inch diameter, centered on the engineered impact point (EIP), and the approximate impact force is at least 1000 lbf and no more than 4000 lbf, the club head volume is less than 300 cc, and the face thickness (530) is less than 0.120 inches. In yet a further embodiment, the face thickness (530) is less than 0.100 inches and the stress-to-deflection ratio is less than 4500 ksi per inch of deflection; while an even further embodiment has a stress-to-deflection ratio that is less than 4300 ksi per inch of deflection.

In addition to the unique stress-to-deflection ratios just discussed, one embodiment of the present invention further includes a face (500) having a characteristic time of at least 220 microseconds and the head volume is less than 200 cubic centimeters. Even further, another embodiment goes even further and incorporates a face (500) having a characteristic time of at least 240 microseconds, a head volume that is less than 170 cubic centimeters, a face height between the maximum top edge height (TEH) and the minimum lower edge (LEH) that is less than 1.50 inches, and a vertical roll radius between 7 inches and 13 inches, which further increases the difficulty in obtaining such a high characteristic time, small face height, and small volume golf club head.

Those skilled in the art know that the characteristic time, often referred to as the CT, value of a golf club head is limited by the equipment rules of the United States Golf Association (USGA). The rules state that the characteristic time of a club head shall not be greater than 239 microseconds, with a maximum test tolerance of 18 microseconds. Thus, it is common for golf clubs to be designed with the goal of a 239 microsecond CT, knowing that due to manufacturing variability that some of the heads will have a CT value higher than 239 microseconds, and some will be lower. However, it is critical that the CT value does not exceed 257 microseconds or the club will not conform to the USGA rules. The USGA publication "Procedure for Measuring the Flexibility of a Golf Clubhead," Revision 2.0, Mar. 25, 2005, is the current standard that sets forth the procedure for measuring the characteristic time.

As previously explained, the golf club head (100) has a blade length (BL) that is measured horizontally from the

origin point toward the toe side of the golf club head a distance that is parallel to the face and the ground plane (GP) to the most distant point on the golf club head in this direction. In one particular embodiment, the golf club head (100) has a blade length (BL) of at least 3.1 inches, a heel blade length section (Abl) is at least 1.1 inches, and a club moment arm (CMA) of less than 1.3 inches, thereby producing a long blade length golf club having reduced face stress, and improved characteristic time qualities, while not being burdened by the deleterious effects of having a large club moment arm (CMA), as is common in oversized fairway woods. The club moment arm (CMA) has a significant impact on the ball flight of off-center hits. Importantly, a shorter club moment arm (CMA) produces less variation between shots hit at the engineered impact point (EIP) and off-center hits. Thus, a golf ball struck near the heel or toe of the present invention will have launch conditions more similar to a perfectly struck shot. Conversely, a golf ball struck near the heel or toe of an oversized fairway wood with a large club moment arm (CMA) would have significantly different launch conditions than a ball struck at the engineered impact point (EIP) of the same oversized fairway wood. Generally, larger club moment arm (CMA) golf clubs impart higher spin rates on the golf ball when perfectly struck in the engineered impact point (EIP) and produce larger spin rate variations in off-center hits. Therefore, yet another embodiment incorporate a club moment arm (CMA) that is less than 1.1 inches resulting in a golf club with more efficient launch conditions including a lower ball spin rate per degree of launch angle, thus producing a longer ball flight.

Conventional wisdom regarding increasing the Zcg value to obtain club head performance has proved to not recognize that it is the club moment arm (CMA) that plays a much more significant role in golf club performance and ball flight. Controlling the club moment arm (CMA), along with the long blade length (BL), long heel blade length section (Abl), while improving the club head's ability to distribute the stresses of impact and thereby improving the characteristic time across the face, particularly off-center impacts, yields launch conditions that vary significantly less between perfect impacts and off-center impacts than has been seen in the past. In another embodiment, the ratio of the golf club head front-to-back dimension (FB) to the blade length (BL) is less than 0.925, as seen in FIGS. 6 and 13. In this embodiment, the limiting of the front-to-back dimension (FB) of the club head (100) in relation to the blade length (BL) improves the playability of the club, yet still achieves the desired high improvements in characteristic time, face deflection at the heel and toe sides, and reduced club moment arm (CMA). The reduced front-to-back dimension (FB), and associated reduced Zcg, of the present invention also significantly reduces dynamic lofting of the golf club head. Increasing the blade length (BL) of a fairway wood, while decreasing the front-to-back dimension (FB) and incorporating the previously discussed characteristics with respect to the stress reducing feature (1000), minimum heel blade length section (Abl), and maximum club moment arm (CMA), produces a golf club head that has improved playability that would not be expected by one practicing conventional design principles. In yet a further embodiment a unique ratio of the heel blade length section (Abl) to the golf club head front-to-back dimension (FB) has been identified and is at least 0.32. Yet another embodiment incorporates a ratio of the club moment arm (CMA) to the heel blade length section (Abl). In this embodiment the ratio of club moment arm (CMA) to the heel blade length section (Abl) is less than

0.9. Still a further embodiment uniquely characterizes the present fairway wood golf club head with a ratio of the heel blade length section (Abl) to the blade length (BL) that is at least 0.33. A further embodiment has recognized highly beneficial club head performance regarding launch conditions when the transfer distance (TD) is at least 10 percent greater than the club moment arm (CMA). Even further, a particularly effective range for fairway woods has been found to be when the transfer distance (TD) is 10 percent to 40 percent greater than the club moment arm (CMA). This range ensures a high face closing moment (MOI_{fc}) such that bringing club head square at impact feels natural and takes advantage of the beneficial impact characteristics associated with the short club moment arm (CMA) and CG location.

Referring now to FIG. 10, in one embodiment it was found that a particular relationship between the top edge height (TEH) and the Y_{cg} distance further promotes desirable performance and feel. In this embodiment a preferred ratio of the Y_{cg} distance to the top edge height (TEH) is less than 0.40; while still achieving a long blade length of at least 3.1 inches, including a heel blade length section (Abl) that is at least 1.1 inches, a club moment arm (CMA) of less than 1.1 inches, and a transfer distance (TD) of at least 1.2 inches, wherein the transfer distance (TD) is between 10 percent to 40 percent greater than the club moment arm (CMA). This ratio ensures that the CG is below the engineered impact point (EIP), yet still ensures that the relationship between club moment arm (CMA) and transfer distance (TD) are achieved with club head design having a stress reducing feature (1000), a long blade length (BL), and long heel blade length section (Abl). As previously mentioned, as the CG elevation decreases the club moment arm (CMA) increases by definition, thereby again requiring particular attention to maintain the club moment arm (CMA) at less than 1.1 inches while reducing the Y_{cg} distance, and a significant transfer distance (TD) necessary to accommodate the long blade length (BL) and heel blade length section (Abl). In an even further embodiment, a ratio of the Y_{cg} distance to the top edge height (TEH) of less than 0.375 has produced even more desirable ball flight properties. Generally the top edge height (TEH) of fairway wood golf clubs is between 1.1 inches and 2.1 inches.

In fact, most fairway wood type golf club heads fortunate to have a small Y_{cg} distance are plagued by a short blade length (BL), a small heel blade length section (Abl), and/or long club moment arm (CMA). With reference to FIG. 3, one particular embodiment achieves improved performance with the Y_{cg} distance less than 0.65 inches, while still achieving a long blade length of at least 3.1 inches, including a heel blade length section (Abl) that is at least 1.1 inches, a club moment arm (CMA) of less than 1.1 inches, and a transfer distance (TD) of at least 1.2 inches, wherein the transfer distance (TD) is between 10 percent to 40 percent greater than the club moment arm (CMA). As with the prior disclosure, these relationships are a delicate balance among many variables, often going against traditional club head design principles, to obtain desirable performance. Still further, another embodiment has maintained this delicate balance of relationships while even further reducing the Y_{cg} distance to less than 0.60 inches.

As previously touched upon, in the past the pursuit of high MOI_y fairway woods led to oversized fairway woods attempting to move the CG as far away from the face of the club, and as low, as possible. With reference again to FIG. 8, this particularly common strategy leads to a large club moment arm (CMA), a variable that the present embodiment seeks to reduce. Further, one skilled in the art will appreciate

that simply lowering the CG in FIG. 8 while keeping the Z_{cg} distance, seen in FIGS. 2 and 6, constant actually increases the length of the club moment arm (CMA). The present invention is maintaining the club moment arm (CMA) at less than 1.1 inches to achieve the previously described performance advantages, while reducing the Y_{cg} distance in relation to the top edge height (TEH); which effectively means that the Z_{cg} distance is decreasing and the CG position moves toward the face, contrary to many conventional design goals.

As explained throughout, the relationships among many variables play a significant role in obtaining the desired performance and feel of a golf club. One of these important relationships is that of the club moment arm (CMA) and the transfer distance (TD). One particular embodiment has a club moment arm (CMA) of less than 1.1 inches and a transfer distance (TD) of at least 1.2 inches; however in a further particular embodiment this relationship is even further refined resulting in a fairway wood golf club having a ratio of the club moment arm (CMA) to the transfer distance (TD) that is less than 0.75, resulting in particularly desirable performance. Even further performance improvements have been found in an embodiment having the club moment arm (CMA) at less than 1.0 inch, and even more preferably, less than 0.95 inches. A somewhat related embodiment incorporates a mass distribution that yields a ratio of the X_{cg} distance to the Y_{cg} distance of at least two.

A further embodiment achieves a Y_{cg} distance of less than 0.65 inches, thereby requiring a very light weight club head shell so that as much discretionary mass as possible may be added in the sole region without exceeding normally acceptable head weights, as well as maintaining the necessary durability. In one particular embodiment this is accomplished by constructing the shell out of a material having a density of less than 5 g/cm³, such as titanium alloy, non-metallic composite, or thermoplastic material, thereby permitting over one-third of the final club head weight to be discretionary mass located in the sole of the club head. One such nonmetallic composite may include composite material such as continuous fiber pre-preg material (including thermosetting materials or thermoplastic materials for the resin). In yet another embodiment the discretionary mass is composed of a second material having a density of at least 15 g/cm³, such as tungsten. An even further embodiment obtains a Y_{cg} distance is less than 0.55 inches by utilizing a titanium alloy shell and at least 80 grams of tungsten discretionary mass, all the while still achieving a ratio of the Y_{cg} distance to the top edge height (TEH) is less than 0.40, a blade length (BL) of at least 3.1 inches with a heel blade length section (Abl) that is at least 1.1 inches, a club moment arm (CMA) of less than 1.1 inches, and a transfer distance (TD) of at least 1.2 inches.

A further embodiment recognizes another unusual relationship among club head variables that produces a fairway wood type golf club exhibiting exceptional performance and feel. In this embodiment it has been discovered that a heel blade length section (Abl) that is at least twice the Y_{cg} distance is desirable from performance, feel, and aesthetics perspectives. Even further, a preferably range has been identified by appreciating that performance, feel, and aesthetics get less desirable as the heel blade length section (Abl) exceeds 2.75 times the Y_{cg} distance. Thus, in this one embodiment the heel blade length section (Abl) should be 2 to 2.75 times the Y_{cg} distance.

Similarly, a desirable overall blade length (BL) has been linked to the Y_{cg} distance. In yet another embodiment preferred performance and feel is obtained when the blade

21

length (BL) is at least 6 times the Ycg distance. Such relationships have not been explored with conventional golf clubs because exceedingly long blade lengths (BL) would have resulted. Even further, a preferable range has been identified by appreciating that performance and feel become less desirable as the blade length (BL) exceeds 7 times the Ycg distance. Thus, in this one embodiment the blade length (BL) should be 6 to 7 times the Ycg distance.

Just as new relationships among blade length (BL) and Ycg distance, as well as the heel blade length section (Abl) and Ycg distance, have been identified; another embodiment has identified relationships between the transfer distance (TD) and the Ycg distance that produce a particularly playable golf club. One embodiment has achieved preferred performance and feel when the transfer distance (TD) is at least 2.25 times the Ycg distance. Even further, a preferable range has been identified by appreciating that performance and feel deteriorate when the transfer distance (TD) exceeds 2.75 times the Ycg distance. Thus, in yet another embodiment the transfer distance (TD) should be within the relatively narrow range of 2.25 to 2.75 times the Ycg distance for preferred performance and feel.

All the ratios used in defining embodiments of the present invention involve the discovery of unique relationships among key club head engineering variables that are inconsistent with merely striving to obtain a high MOI_y or low CG using conventional golf club head design wisdom. Numerous alterations, modifications, and variations of the preferred embodiments disclosed herein will be apparent to those skilled in the art and they are all anticipated and contemplated to be within the spirit and scope of the instant invention. Further, although specific embodiments have been described in detail, those with skill in the art will understand that the preceding embodiments and variations can be modified to incorporate various types of substitute and or additional or alternative materials, relative arrangement of elements, and dimensional configurations. Accordingly, even though only few variations of the present invention are described herein, it is to be understood that the practice of such additional modifications and variations and the equivalents thereof, are within the spirit and scope of the invention as defined in the following claims.

We claim:

1. A multi-material iron-type golf club head comprising:
 - (i) a shell having a face positioned at a front portion where the golf club head impacts a golf ball, the face being opposite a rear portion and extending between a top portion and a sole, thereby defining a closed internal volume, wherein the golf club head includes a first material having a first density, and a second material having a second density, wherein the second density is greater than the first density;
 - (ii) the face has a face thickness that varies from a minimum face thickness to a maximum face thickness, a characteristic time of at least 220 microseconds, and an engineered impact point, a face height, a top edge height, and a lower edge height, wherein the face has a blade length measured horizontally from an origin point toward a toe side of the golf club head to the most distant point on the golf club head in this direction, wherein the blade length includes a toe blade length section and a heel blade length section measured in the same direction as the blade length from the origin point to the engineered impact point, wherein the heel blade length section is at least 1.1", and a front-to-back dimension from a furthest forward point on the face to the furthest rearward point at the rear portion, wherein

22

a stress-to-deflection ratio of the peak stress on the face to the peak deflection of the face when exposed to an approximate impact force is less than 5500 ksi per inch of deflection, when the approximate impact force is applied to the face over a 0.6 inch diameter, centered on the engineered impact point, and the approximate impact force is at least 1000 lbf and no more than 4000 lbf;

- (iii) a bore having a center that defines a shaft axis which intersects with a horizontal ground plane to define the origin point, wherein the bore is located at a heel side of the golf club head, and wherein the toe side of the golf club head is located opposite of the heel side; and
- (iv) a center of gravity located:
 - (a) vertically from the origin point a distance Ycg;
 - (b) horizontally from the origin point toward the toe side of the golf club head a distance Xcg;
 - (c) a distance Zcg from the origin toward the rear portion in a direction generally orthogonal to the vertical direction used to measure Ycg and generally orthogonal to the horizontal direction used to measure Xcg;
 - (d) a club moment arm from the center of gravity to the engineered impact point is less than 1.1", wherein a ratio of the club moment arm to the heel blade length section is less than 0.9; and
 - (e) a transfer distance measured horizontally from the center of gravity to a vertical line extending from the origin, wherein the transfer distance is at least 10% greater than the club moment arm, and a ratio of the club moment arm to the transfer distance is less than 0.75.
2. The multi-material iron-type golf club head of claim 1, wherein the second density is at least twice the first density.
3. The multi-material iron-type golf club head of claim 2, wherein a ratio of the front-to-back dimension to the blade length is less than 0.925, a ratio of the heel blade length section to the front-to-back dimension is at least 0.32, and the club moment arm is less than 1".
4. The multi-material iron-type golf club head of claim 3, wherein the second density is at least 15 g/cm³.
5. The multi-material iron-type golf club head of claim 3, wherein the characteristic time is at least 240 microseconds.
6. The multi-material iron-type golf club head of claim 1, wherein a ratio of the Ycg distance to the top edge height is less than 0.40, and the transfer distance is at least 1.2".
7. The multi-material iron-type golf club head of claim 6, wherein the ratio of the Ycg distance to the top edge height is less than 0.375, and the club moment arm is less than 0.95".
8. The multi-material iron-type golf club head of claim 1, wherein the blade length is at least 3.1", a ratio of the front-to-back dimension to the blade length is less than 0.925, a ratio of the heel blade length section to the front-to-back dimension is at least 0.32, and the club moment arm is less than 1".
9. The multi-material iron-type golf club head of claim 8, wherein the first density is less than 5 g/cm³ and the maximum face thickness is less than 0.120 inches.
10. The multi-material iron-type golf club head of claim 8, wherein the second material is at least 80 grams.
11. The multi-material iron-type golf club head of claim 1, wherein the stress-to-deflection ratio is less than 5000 ksi per inch of deflection.
12. The multi-material iron-type golf club head of claim 11, wherein the maximum face thickness is less than 0.100 inches.

23

13. The multi-material iron-type golf club head of claim 1, further including a sole located SRF located at least partially on the sole, wherein the sole located SRF has a SSRF length that is at least as great as the heel blade length section, a SSRF leading edge having a SSRF leading edge offset, a SSRF trailing edge, a SSRF width, and a SSRF depth, wherein at least one of the SSRF leading edge and the SSRF trailing edge has a SSRF wall extending into the golf club head a distance of at least ten percent of the Ycg distance.

14. The multi-material iron-type golf club head of claim 13, wherein the SSRF width of at least one point along the SSRF length is at least ten percent of the Zcg distance, and the SSRF leading edge is curved.

15. A multi-material iron-type golf club head comprising:

(i) a shell having a face positioned at a front portion where the golf club head impacts a golf ball, the face being opposite a rear portion and extending between a top portion and a sole, thereby defining a closed internal volume, wherein the golf club head includes a first material having a first density of less than 5 g/cm³, and a second material having a second density, wherein the second density is at least twice the first density;

(ii) the face has a face thickness that varies from a minimum face thickness to a maximum face thickness, a characteristic time of at least 220 microseconds, and an engineered impact point, a face height, a top edge height, and a lower edge height, wherein the face has a blade length measured horizontally from an origin point toward a toe side of the golf club head to the most distant point on the golf club head in this direction, wherein the blade length includes a toe blade length section and a heel blade length section measured in the same direction as the blade length from the origin point to the engineered impact point, wherein the heel blade length section is at least 1.1", and a front-to-back dimension from a furthest forward point on the face to the furthest rearward point at the rear portion, wherein a stress-to-deflection ratio of the peak stress on the face to the peak deflection of the face when exposed to an approximate impact force is less than 5500 ksi per inch of deflection, when the approximate impact force is applied to the face over a 0.6 inch diameter, centered on the engineered impact point, and the approximate impact force is at least 1000 lbf and no more than 4000 lbf;

(iii) a bore having a center that defines a shaft axis which intersects with a horizontal ground plane to define the

24

origin point, wherein the bore is located at a heel side of the golf club head, and wherein the toe side of the golf club head is located opposite of the heel side; and (iv) a center of gravity located:

(a) vertically from the origin point a distance Ycg;
(b) horizontally from the origin point toward the toe side of the golf club head a distance Xcg;

(c) a distance Zcg from the origin toward the rear portion in a direction generally orthogonal to the vertical direction used to measure Ycg and generally orthogonal to the horizontal direction used to measure Xcg;

(d) a club moment arm from the center of gravity to the engineered impact point is less than 0.95", wherein a ratio of the club moment arm to the heel blade length section is less than 0.9; and

(e) a transfer distance measured horizontally from the center of gravity to a vertical line extending from the origin, wherein the transfer distance is at least 10% greater than the club moment arm, a ratio of the club moment arm to the transfer distance is less than 0.75, a ratio of the front-to-back dimension to the blade length is less than 0.925, and a ratio of the heel blade length section to the front-to-back dimension is at least 0.32.

16. The multi-material iron-type golf club head of claim 15, wherein the second material is at least 80 grams.

17. The multi-material iron-type golf club head of claim 16, wherein the second density is at least 15 g/cm³.

18. The multi-material iron-type golf club head of claim 16, wherein a ratio of the Ycg distance to the top edge height is less than 0.40.

19. The multi-material iron-type golf club head of claim 15, wherein the Ycg distance is less than 0.65 inches.

20. The multi-material iron-type golf club head of claim 15, further including a sole located SRF located at least partially on the sole, wherein the sole located SRF has a SSRF length that is at least as great as the heel blade length section, a SSRF leading edge having a SSRF leading edge offset, a SSRF trailing edge, a SSRF width, and a SSRF depth, wherein at least one of the SSRF leading edge and the SSRF trailing edge have a SSRF wall extending into the golf club head a distance of at least ten percent of the Ycg distance, and the SSRF width of at least one point along the SSRF length is at least ten percent of the Zcg distance.

* * * * *